

*Pace Arrow*<sup>®</sup>  
FLEETWOOD, RV

**2000**

©1999 by Fleetwood Enterprises, Inc. All rights reserved. No part of this publication may be reproduced or transmitted in any form or by any means, electronic or mechanical, including photocopying, recording, or by any information storage or retrieval system without written permission from Fleetwood Enterprises, Inc.

Manufacturing subsidiaries of Fleetwood Enterprises, Inc. build the following motor homes:  
Pace Arrow • Pace Arrow Vision • Southwind • Southwind Storm • Bounder • Bounder Diesel  
• Discovery • Flair • Tioga • Jamboree • American Eagle • American Dream • American Heritage  
• American Tradition

**This page intentionally blank.**

# LIMITED ONE-YEAR/THREE-YEAR WARRANTY

---

**For Motor Homes Manufactured by subsidiaries of Fleetwood Enterprises, Inc.,  
sold in the United States and Canada**

Your new motor home, including the structure, plumbing, heating and electrical systems, and all appliances and equipment installed by the manufacturer, is warranted under normal use to be free from manufacturing defects in material or workmanship. Defects or damage to paint, graphics, exterior materials, upholstery or other appearance items that may occur prior to delivery are usually corrected during the inspection process at the manufacturing plant or the dealership.

## **COVERAGE PROVIDED**

The warranty extends to the first retail purchaser and his transferee(s) and begins on the date of original retail delivery or the date the motor home is first placed into service as a rental, commercial or demonstrator unit (whichever occurs first). The warranty extends for the following periods:

1. For all defects (other than structural) the warranty extends for a period of one year from such date or until the unit has received 15,000 total miles of use as determined by the mileage shown on the odometer (whichever occurs first).
2. For structural defects, 3 years; structural defects are limited to the following: roof structure, sub-floor structure, exterior walls, interior walls and ceilings.

Written notice of defects must be given to the selling dealer or manufacturer not later than ten (10) days after the expiration of the warranty period.

---

The owner is responsible for normal maintenance as described in the Owner's Manual; however, minor adjustments (such as adjustments to the interior or exterior doors, LP regulator pressure, cabinet latches, TV antenna control, etc.) will be performed by the dealer during the first 90 days of warranty coverage. Thereafter, such adjustments are the responsibility of the owner as normal maintenance unless required as a direct result of repair or replacement of a defective part under this warranty.

## **OWNER'S OBLIGATIONS**

If a problem occurs which the owner believes is covered by this warranty, the owner shall contact the selling dealer, or the Fleetwood Service Center, giving sufficient information to resolve the matter. The owner shall deliver the motor home to the dealer or the Fleetwood Service Center location for warranty service.

---

# **WARRANTY**

---

By agreement with the manufacturer, the dealer is obligated to maintain the motor home prior to retail sale, to perform a detailed pre-delivery inspection and to repair or replace any parts necessary to correct defects in material or workmanship.

## **DEALER'S OBLIGATIONS**

---

If the dealer is unable or unwilling to resolve a problem which the owner is convinced is covered by the warranty, the owner should contact the Fleetwood Service Center at the address listed below and provide the Fleetwood Service Center with a description in writing of the problem and attempts made to resolve it.

## **WHEN THE DEALER DOES NOT RESOLVE THE PROBLEM**

---

Upon receipt of notice of a claim, where the dealer was unable or unwilling to resolve the problem, the Fleetwood Service Center will repair or replace any parts necessary to correct defects in material or workmanship or will take other appropriate action as may be required.

## **MANUFACTURER'S OBLIGATIONS**

---

### **This warranty does not cover:**

1. The automotive system (including the chassis and drive train), tires and batteries, which are covered by the separate warranties of the respective manufacturers of these components.
2. Defects caused by or related to:
  - a. Abuse, misuse, negligence or accident;
  - b. Failure to comply with instructions contained in the Owner's Manual;

## **WHAT IS NOT COVERED BY THIS WARRANTY**

# WARRANTY

---

- c. Alteration or modification of the motor home;
  - d. Environmental conditions (salt, hail, chemicals in the atmosphere, etc.)
3. Normal deterioration due to wear or exposure, such as fading of fabrics or drapes, carpet wear, etc.
  4. Normal maintenance and service items, such as light bulbs, fuses, wiper blades, lubricants, etc.
  5. Motor homes on which the odometer reading has been altered.
  6. Transportation to and from dealer or Fleetwood Service Center location, loss of time, inconvenience, commercial loss, loss of use, towing charges, bus fares, vehicle rental, incidental charges such as telephone calls or hotel bills, or other incidental or consequential damages.

Some states do not allow the exclusion or limitation of incidental or consequential damages, so the above limitation or exclusion may not apply to you.

**This warranty gives you specific legal rights, and you may also have other rights which vary from state to state.**

**The manufacturer is not responsible for any undertaking, representation or warranty made by any dealer or other person beyond those expressly set forth in this warranty.**

**Brand Name:** \_\_\_\_\_

**Model:** \_\_\_\_\_

**Serial No.:** \_\_\_\_\_

**Manufacturing Plant:** \_\_\_\_\_

## **For Customer Service assistance, contact:**

Fleetwood Motor Home Service	Fleetwood Motor Home Service
PO Box 5700	PO Box 1007
Riverside, CA 92507	Decatur, IN 46733
(800) 322-8216	(800) 322-8216

**This page intentionally blank.**

The particle board, hardwood plywood, or paneling used in your motor home are made with urea-formaldehyde. The companies that supply us with these materials have asked that we tell you about urea-formaldehyde with the statements on this page.

## IMPORTANT NOTICES

### WARNING

This product is manufactured with urea-formaldehyde resin. Formaldehyde vapor may in some people cause headaches, eye, nose and throat irritation, and aggravation of allergies and respiratory problems, such as asthma. Proper ventilation should reduce the risk of such problems.

*Champion International Corporation*

### WARNING

This product is manufactured with a urea-formaldehyde resin and will release small quantities of formaldehyde. Formaldehyde levels in the indoor air can cause temporary eye and respiratory irritation, and may aggravate respiratory conditions or allergies. Ventilation will reduce indoor formaldehyde levels.

*Weyerhaeuser Corporation*

### WARNING

This product contains components containing or manufactured with 1,1,1 Trichloroethane, a substance that may be harmful to the public health and environment by destroying ozone in the upper atmosphere.

### WARNING

**Irritant:** This product contains a urea-formaldehyde resin and may release formaldehyde vapors in low concentrations. Formaldehyde can be irritating to the eyes and upper respiratory system of especially susceptible persons such as those with allergies or respiratory ailments. Use with adequate ventilation. If symptoms develop, consult your physician.

*Georgia-Pacific Corporation*

Ventilation is important for making the interior of your motor home comfortable. Please read the section about ventilation and prolonged occupancy in the *Living With Your Motor Home* chapter in this *Owner's Manual*.

We are required to tell you consumer information provided by the *National Fire Prevention Association (NFPA)* and the *American National Standards Institute (ANSI)*. The information and warnings found on these pages may also be found in other chapters of this *Owner's Manual*. Please see the *LP Gas System* and *Appliances* chapters for other safety and operating information.

## **SAFETY REGULATIONS REGARDING LP GAS SYSTEMS AND LP GAS APPLIANCES**

**! WARNING**

Do not bring or store LP gas containers, gasoline or other flammable liquids inside the vehicle because a fire or explosion may result.

A warning label has been located near the LP gas container. This label reads: **DO NOT FILL CONTAINER(S) TO MORE THAN 80-PERCENT OF CAPACITY.**

Overfilling the LP gas container can result in uncontrolled gas flow which can cause fire or explosion. A properly filled container will contain approximately 80- percent of its volume as liquid LP gas.

The following label has been placed in the vehicle near the range:

**IF YOU SMELL GAS:**

1. Extinguish any open flames, pilot lights, and all smoking materials.
2. Do not touch electrical switches.
3. Shut off the gas supply at the container valve(s) or gas supply connection.
4. Open doors and other ventilation openings.
5. Leave the area until the odor clears.
6. Have the gas system checked and leakage source corrected before using again.

LP gas regulators must always be installed with the diaphragm vent facing downward. Regulators that are not in compartments have been equipped with a protective cover. Make sure that regulator vent faces downward and the cover is kept in place to minimize vent blockage which could result in excessive gas pressure causing fire explosion.



**SAFETY REGULATIONS  
REGARDING  
LP GAS SYSTEMS AND  
LP GAS APPLIANCES**

**! WARNING**

It is not safe to use cooking appliances for comfort heating. Cooking appliances need fresh air for safe operation.

Before operation:

1. Open overhead vent or turn on exhaust fan, and
2. Open window.

This warning label has been located in the cooking area to remind you to provide an adequate supply of fresh air for combustion. Unlike homes, the amount of oxygen supply is limited due to the size of the recreational vehicle, and proper ventilation when using the cooking appliance(s) will avoid dangers of asphyxiation. It is especially important that cooking appliances not be used for comfort heating as the danger of asphyxiation is greater when the appliance is used for long periods of time.

**! WARNING**

Portable fuel-burning equipment, including wood and charcoal grills and stoves, shall not be used inside this recreational vehicle. The use of this equipment inside the recreational vehicle may cause fires or asphyxiation.

**! WARNING**

LP gas containers shall not be placed or stored inside the vehicle. LP gas containers are equipped with safety devices which relieve excessive pressure by discharging gas to the atmosphere.

**This page intentionally blank.**

## WARRANTY

## SPECIAL NOTICES AND WARNINGS

<b>01 INTRODUCTION .....</b>	<b>01-1</b>
WARRANTIES .....	01-2
WARRANTY SERVICE .....	01-5
SUGGESTIONS FOR OBTAINING SERVICE	
FOR YOUR MOTOR HOME .....	01-6
REPORTING SAFETY DEFECTS .....	01-7
OWNER'S INFORMATION PACKAGE .....	01-7
CHASSIS AND VEHICLE IDENTIFICATION .....	01-8
SUSPENSION ALIGNMENT AND TIRE BALANCE.....	01-9
AFTER-MARKET STEERING Aid DEVICES .....	01-9
WARNINGS, TERMS AND CONCEPTS FOR	
SAFE OPERATION OF YOUR MOTOR HOME.....	01-10
<b>02 DRIVER'S CONTROLS.....</b>	<b>02-1</b>
<b>03 ON THE ROAD.....</b>	<b>03-1</b>
MOTOR HOME LOADING .....	03-1
RESPONSIBILITY FOR PROPER LOADING.....	03-1
SOME DEFINITIONS FIRST.....	03-1
TOWING A VEHICLE OR TRAILER.....	03-3
CARRYING CAPACITY AND LOAD DISTRIBUTION .....	03-5
CARRYING CAPACITY LABEL.....	03-6
HOW TO WEIGH YOUR LOADED MOTOR HOME	
WITHOUT A TRAILER OR OTHER TOWED LOAD .....	03-7
HOW TO WEIGH YOUR LOADED MOTOR HOME	
WITH A TRAILER OR OTHER TOWED LOAD .....	03-9
LOADING TIPS.....	03-11

# Table of CONTENTS

---

TIRES .....	03-11
<i>TIRE INFLATION</i> .....	03-12
<i>TIRE REPLACEMENT</i> .....	03-12
<i>IF YOU GET A FLAT TIRE</i> .....	03-13
<i>CHANGING A FLAT TIRE</i> .....	03-13
SEATS AND SEAT BELTS .....	03-14
<i>COMBINATION LAP AND SHOULDER BELTS</i> .....	03-15
<i>SAFETY BELT MAINTENANCE</i> .....	03-15
<i>SAFETY RESTRAINTS FOR CHILDREN</i> .....	03-15
<i>SAFETY BELTS FOR CHILDREN</i> .....	03-16
<i>SAFETY SEATS FOR CHILDREN</i> .....	03-16
DRIVING AND VEHICLE CONTROL .....	03-17
MANEUVERING IN TRAFFIC .....	03-17
<i>USING THE ENGINE TO SLOW THE MOTOR HOME</i> .....	03-19
REAR VIEW VIDEO MONITOR .....	03-20
BODY UNDERCOATING .....	03-20
FUEL AND FUEL SYSTEMS.....	03-21
<i>FUEL TYPES AND VAPOR LOCK</i> .....	03-21
ENGINE FAN .....	03-22
EXHAUST SYSTEM HEAT .....	03-22
ENGINE TEMPERATURE GAUGES.....	03-23
CARBON MONOXIDE SAFETY PRECAUTIONS .....	03-23
<i>CARBON MONOXIDE DETECTOR/ALARM</i> .....	03-24
EMERGENCY TOWING.....	03-24
ATTACHING ACCESSORIES TO YOUR MOTOR HOME.....	03-25

## 04 Living With Your Motor Home ...04-1

Hydraulic Leveling System .....	04-1
Power Entry Step .....	04-1
Entry Doors and Screens .....	04-2

# Table of CONTENTS

---

Windows .....	04-2
<i>EMERGENCY Exit Window</i> .....	04-2
REMOTE MIRROR CONTROL .....	04-3
SUN VISORS .....	04-3
Window SHADES .....	04-3
<i>Day/Night Shades</i> .....	04-3
STORAGE .....	04-4
<i>EXTERIOR COMPARTMENTS</i> .....	04-4
<i>INTERIOR STORAGE</i> .....	04-4
INTERIOR AND FURNISHINGS .....	04-5
<i>DINETTE CONVERSION</i> .....	04-5
<i>INTERIOR LIGHTING</i> .....	04-6
<i>OVERHEAD VENTS</i> .....	04-7
<i>Folding CHAIRS</i> .....	04-7
MONITOR PANEL .....	04-8
EFFECTS OF PERMANENT OCCUPANCY .....	04-9
<i>CONDENSATION AND HOW TO CONTROL IT</i> .....	04-9
<i>Dripping Ceiling VENTS</i> .....	04-14
FIRE SAFETY .....	04-15
<i>FIRE SAFETY PRECAUTIONS</i> .....	04-16
<i>SMOKE DETECTOR/ALARM</i> .....	04-17
Slide-Out ROOMS .....	04-17
<b>05 PLUMBING SYSTEMS .....</b>	<b>05-1</b>
FRESH WATER SYSTEM .....	05-1
<i>EXTERNAL FRESH WATER Hookup</i> .....	05-1
<i>Filling the ON-BOARD WATER Tank</i> .....	05-2
<i>DRAINING THE FRESH WATER Tank</i> .....	05-3
<i>WATER PUMP</i> .....	05-3
<i>WATER Filter</i> .....	05-4
<i>LOW POINT DRAINS</i> .....	05-4
<i>TROUBLESHOOTING THE FRESH WATER SYSTEM</i> .....	05-5

# Table of CONTENTS

---

<i>LEAKS</i> .....	05-5
<i>SANITIZING THE FRESH WATER SYSTEM</i> .....	05-6
<i>EXTERIOR SHOWER</i> .....	05-6
<i>DRINKING WATER FILTER SYSTEM</i> .....	05-6
WASTE WATER SYSTEM .....	05-7
<i>TOILET</i> .....	05-7
<i>DRAINING THE HOLDING TANKS</i> .....	05-8
<i>BLACK TANK FLUSH SYSTEM</i> .....	05-10
<i>HOLDING TANK CARE</i> .....	05-11
<i>EXTREME COLD WEATHER USAGE</i> .....	05-12
<b>06 ELECTRICAL SYSTEMS</b> .....	<b>06-1</b>
CHASSIS 12-VOLT ELECTRICAL SYSTEM .....	06-1
<i>CHASSIS BULBS AND FUSES</i> .....	06-1
FLEETWOOD 12-VOLT HOUSE AND AUTOMOTIVE SYSTEM .....	06-2
<i>BATTERIES</i> .....	06-2
<i>BATTERY DISCONNECT</i> .....	06-2
<i>BATTERY INSPECTION AND CARE</i> .....	06-3
<i>BATTERY CHARGING</i> .....	06-4
<i>SELECTING A REPLACEMENT BATTERY</i> .....	06-5
<i>SOLAR PANEL</i> .....	06-5
<i>AUXILIARY START SYSTEM</i> .....	06-5
120-VOLT SYSTEM .....	06-6
<i>POWER CONVERTER</i> .....	06-6
<i>GROUND FAULT CIRCUIT INTERRUPTER</i> .....	06-7
<i>GENERATOR</i> .....	06-8
<i>GENERATOR FUEL SUPPLY</i> .....	06-8
<i>GENERATOR OPERATION</i> .....	06-8
<i>GENERATOR OPERATING SAFETY PRECAUTIONS</i> .....	06-9
ELECTRONIC CLIMATE CONTROL SYSTEM .....	06-10
ELECTRICAL WIRING DIAGRAMS .....	06-10
MOTOR HOME FUSES AND CIRCUIT BREAKERS .....	06-11

# Table of CONTENTS

---

<b>07 LP GAS SYSTEM.....</b>	<b>07-1</b>
LP GAS SAFETY PRECAUTIONS.....	07-2
SYSTEM COMPONENTS.....	07-4
<i>HOSES.....</i>	<i>07-4</i>
<i>LP GAS REGULATOR.....</i>	<i>07-4</i>
USING LP GAS SYSTEM AT LOW TEMPERATURES.....	07-5
FILLING LP GAS TANK.....	07-6
LP GAS SYSTEM LEAK CHECKS.....	07-7
LP LEAK DETECTOR.....	07-8
LIGHTING LP GAS APPLIANCES.....	07-9
<b>08 APPLIANCES.....</b>	<b>08-1</b>
WATER HEATER.....	08-1
<i>WATER HEATER BYPASS VALVE.....</i>	<i>08-2</i>
REFRIGERATOR.....	08-2
FURNACE.....	08-3
RANGE.....	08-4
RANGE EXHAUST HOOD.....	08-4
AIR CONDITIONER ( <i>If Equipped</i> ).....	08-4
ENTERTAINMENT EQUIPMENT.....	08-5
<i>120-Volt VCR (If Equipped).....</i>	<i>08-5</i>
<i>120/12-Volt Televisions (If Equipped).....</i>	<i>08-5</i>
VIDEO SWITCHER.....	08-6
TV ANTENNA.....	08-6
SATELLITE DISH ANTENNA ( <i>If Equipped</i> ).....	08-6
TV AND RADIO INTERFERENCE.....	08-7
MISCELLANEOUS APPLIANCES.....	08-8
<b>09 MAINTENANCE.....</b>	<b>09-1</b>
EXTERIOR.....	09-1
<i>STAINS.....</i>	<i>09-2</i>
<i>Windows, Doors, Vents and Locks.....</i>	<i>09-3</i>

# Table of Contents

---

RUBBER ROOF SYSTEM .....	09-3
<i>CLEANING</i> .....	09-3
<i>CARE</i> .....	09-4
SEALANT RENEWAL.....	09-4
<i>DOOR, Window, Roof COMPONENT</i> <i>AND Molding RESEALING</i> .....	09-5
INTERIOR.....	09-6
<i>FABRICS</i> .....	09-6
<i>LAMINATE Top CARE</i> .....	09-6
<i>CUTTING Block</i> .....	09-6
<i>Walls AND Ceiling PANELS</i> .....	09-7
<i>BATHtub AND Plastic SHOWER Stall</i> .....	09-7
<i>FLOORS AND CARPETING</i> .....	09-7
<i>ENGINE ACCESS</i> .....	09-7
MAINTENANCE CHECKLIST.....	09-8
TRAILER HITCH CONNECTOR WIRING.....	09-8
EXTERIOR SEALANTS .....	09-8
GENERATOR FILTERS .....	09-8
TAG AXLE SYSTEM.....	09-8
LAMPS AND BULBS .....	09-9
FUSES AND CIRCUIT BREAKERS .....	09-9
MAINTENANCE CHART.....	09-10

## 10 MOTOR HOME STORAGE..... 10-1

STORAGE CHECKLISTS.....	10-1
<i>SHORT-TERM STORAGE</i> .....	10-1
<i>LONG-TERM STORAGE</i> .....	10-3
WINTERIZATION.....	10-5
<i>WATER SYSTEM WINTERIZING</i> .....	10-5
REACTIVATING THE MOTOR HOME AFTER STORAGE.....	10-9

## Glossary



---

# INTRODUCTION

Welcome to the recreational vehicle life-style and the growing family of motor home owners. We sincerely thank you for choosing a Fleetwood motor home!

Your motor home has been designed to provide you with years of carefree, pleasant traveling and vacationing. It conforms with, or exceeds, applicable *American National Standards Institute (ANSI)*, *National Fire Protection Association (NFPA)*, *Canadian Standards Association (CSA)* (units built for Canada only), *Federal Motor Vehicle Safety Standards (FMVSS)* and *Environmental Protection Agency (EPA)* and *California Air Resources Board (CARB)* regulations. These standards and regulations establish the plumbing, heating, electrical and other requirements for safety. The seal attached just outside the entry door indicates compliance with *ANSI* or *CSA* standards.

Like all finely crafted equipment, your motor home will require care and regular maintenance in order to deliver maximum value and performance. The dealer will give you basic operating and maintenance instructions. However, supplement this by reading all instructional material furnished with the motor home in the *Owner's Information Package* and motor home *Chassis Operator's/Owner's Guide/Manual*. This information outlines important areas of operation and maintenance for you to follow for safe, trouble-free service from your motor home. Study these instructions carefully. A good working knowledge of your motor home and how to care for it will help you enjoy many miles and years of recreational living.



## NOTE

*This manual describes many features of your motor home and includes instructions for its safe use. This manual, including photographs and illustrations, is of a general nature only. Some equipment and features described or shown in this manual may be optional. Because of the continuous program of product improvement conducted by Fleetwood, it is possible that recent product changes may not be included. The instructions included in this manual are intended as a guide, and in no way extend the responsibilities of the manufacturing subsidiary, parent company or affiliates beyond the standard written warranty as presented in this manual.*

# INTRODUCTION

---

In this manual, statements preceded by the following words are of special significance:

## **WARNING**

means that there is the possibility of personal injury to yourself and others.

## **CAUTION**

means that there is the possibility of damage to the vehicle.

## **NOTE**

indicates points of particular interest for more efficient and convenient operation.

Please pay close attention to these statements while you read this manual.

If you have any questions regarding operation, maintenance, or service, please contact your dealer immediately so he can assist you. Your dealer's Service or Sales Department will handle any normal problems which might occur.

## **NOTE**

*This product is designed for recreational use and short term occupancy only. It is not designed or intended to be used as permanent housing. Use of this product for long term or permanent occupancy may lead to premature deterioration of interior finishes, fabrics, carpeting, drapes, and appliances and fixtures. Damage or deterioration due to long term occupancy is not considered normal, and will under the terms of the warranty constitute misuse, abuse, or neglect, thereby reducing your warranty protection. Before considering this motor home for long term occupancy, consult the relevant sections in this manual.*

---

Your motor home is covered by one of the most comprehensive warranty programs in the RV industry. Please refer to the warranty in the front of this manual. It explains your rights and obligations, as well as the rights and obligations of the dealer and manufacturer. Please read this section carefully. You will be better informed in case you have a warranty-related problem, and your dealer will be better able to get you on the road again. If you have any questions about the warranty or what it does or does not cover, please contact your dealer.

## WARRANTIES

The materials in your *Owner's Information Package* contain warranty information and operating instructions on the various appliances and components in your motor home.

Warranty registration cards for these items should be filled out and mailed as soon as possible after you take delivery of your motor home. If you do not have operating instructions for a particular appliance, contact your dealer.

You will automatically receive an *Ownercare Card* approximately 3-4 weeks after delivery of your new motor home. This card is imprinted with your name, the motor home serial number, and manufacturing subsidiary location. If your motor home ever needs warranty service, present this card to the dealer, or have it available when contacting a Fleetwood Service Center.

The motor home has been thoroughly inspected before shipment. Your dealer is responsible for performing a complete predelivery inspection of the chassis and all motor home components as specified in the predelivery checklists supplied by the motor home and chassis manufacturers. You should receive a copy of these completed checklists from your dealer when your motor home is delivered to you.

As a part of the predelivery inspection procedure, the dealer is responsible for road testing the motor home, noting and correcting any steering problems before delivery.

***Fleetwood and its subsidiaries will not be responsible for front end alignment after this predelivery inspection is done.***

You should return your motor home to the selling dealer for warranty service. If this is not possible, you may contact any other authorized Fleetwood motor home dealer. The service department at any of the locations listed at the back of this manual can help you find a dealer in your area.

If you have a warranty or service concern about the chassis portion of your vehicle please be aware that you may go directly to an authorized chassis dealer for service. This may

## **INTRODUCTION**

---

save you time and effort as the chassis warranty is administered by the chassis manufacturer. Consult your area phone directory for an authorized dealer and make arrangements with their service department. If you are unsure if the concern is chassis related, feel free to contact your Fleetwood dealer to assist you.

If, for some reason, a problem is not handled to your satisfaction:

1. Discuss any warranty-related problems directly with the manager and/or owner of the dealership, giving them an opportunity to help the service department resolve the matter for you.
2. If a problem arises that has not been resolved to your satisfaction by your local dealer, contact the Fleetwood Service Center. The locations are listed in the back of this manual. Please contact the one nearest you.
3. We sincerely believe that your dealer and the factory representative will be able to solve any problem which might arise. If their combined efforts are not satisfactory, please send a letter describing the circumstances to:

**Fleetwood Enterprises, Inc.**  
**Motor Home Division**  
**PO Box 7638 Riverside, CA 92513-7638**

Please include the brand name and serial number of your motor home. The serial number is located on the identification tag next to the entry door, and on your warranty card.

4. If you wish to call for assistance, please use this toll-free telephone number:

**(800) 322-8216**

There may be times when your motor home will need repairs or parts while you are on the road. If your motor home is repaired by a non-authorized repair facility (non-Fleetwood dealer), be sure to save receipts and especially any parts that are replaced. These parts will usually have to be returned to your dealer before you can be reimbursed for their cost.

## WARRANTY SERVICE

If you need service or warranty information, please see the booklets and other documents included in your *Owner's Information Package*. When contacting any of the equipment manufacturers, always have the model and serial numbers available. Appliance identification numbers will be found on tags or plates attached to the appliance.

Chassis component (engine, transmission, axles, etc.) identification numbers will be located in the manuals included with your motor home.

If you need service or warranty information, the following phone numbers may be helpful:

<i>Refrigerator (Dometic)</i> .....	(800) 544-4881
<i>Range</i> .....	(800) 332-4432
<i>Water Heater (Atwood)</i> .....	(800) 847-7160
<i>Air Conditioner (RVP)</i> .....	(800) 227-5693
<i>Furnace (HydroFlame)</i> .....	(800) 825-4328
<i>Generator/Power Plant (Onan)</i> .....	(800) 222-4871
<i>Entry Step (Kwikkee)</i> .....	(800) 736-9961
<i>Awning (A&amp;E/Dometic)</i> .....	(800) 544-4881

## ***INTRODUCTION***

---

If you need service or warranty information, please see the booklets and other documents included in your *Owner's Information Package*. When contacting any of the equipment manufacturers, always have the model and serial numbers available. Appliance identification numbers will be found on tags or plates attached to the appliance.

If you ever need warranty work done, be sure to have the right papers with you. Take your warranty folder. If required work is not covered under the warranty, your dealer's service department can help you with getting the correct service. Always keep a maintenance log of your motor home's service history.

Always make a written list of the motor home's problems or the specific work you want done. If you've had work done that is not on your maintenance log, especially while out of town, let the service advisor know. Don't keep secrets.

And finally, be reasonable with requests. If you have a long list of service items that need attention and you need your motor home very soon, discuss the situation with the service advisor, listing the items in order of priority. This will help the service department manage their time and will help get you going as quickly as possible.

## **SUGGESTIONS FOR OBTAINING SERVICE FOR YOUR MOTOR HOME**

If you believe that your vehicle has a defect which could cause a crash or could cause injury or death, you should immediately inform the *National Highway Traffic Safety Administration (NHTSA)* in addition to notifying the Fleetwood Service Center at 1-800-322-8216.

If *NHTSA* receives similar complaints, it may open an investigation, and if it finds that a safety defect exists in a group of vehicles, it may order a recall and remedy campaign. However, *NHTSA* cannot become involved in individual problems between you, your dealer or Fleetwood's manufacturing subsidiary.

To contact *NHTSA*, you may either call the Auto Safety Hotline toll-free at 1-800-424-9393 (or 366-0123 in Washington, D.C.) or write to:

**NHTSA**  
**U.S. Department of Transportation**  
**400 Seventh St. SW**  
**Washington, DC 20590**

You can also obtain other information about motor vehicle safety from the Hotline.

---

This package contains valuable documents about your motor home and its equipment and systems. This *Owner's Manual* is in the package. Since this manual does not cover every possible detail of equipment and options installed on or in your motor home, there are booklets and instructional material in the package that will help you safely operate, maintain and troubleshoot those items. Be sure you read all this information and understand the safety and operating instructions included in the package. Additionally, you must follow all maintenance instructions to insure full warranty coverage. If you ever decide to sell or trade your motor home, be sure the new owner receives all the material in this package.

## REPORTING SAFETY DEFECTS

## OWNER'S INFORMATION PACKAGE

# INTRODUCTION

Several numbers are used to identify the vehicle and components used on the vehicle.

The **V.I.N.** or *Vehicle Identification Number* is the identification of the completed vehicle and is the number of the vehicle registration. The V.I.N. is found on the Federal certification tag attached to the interior left sidewall of the motor home driver compartment. Refer to this information when ordering parts from the chassis manufacturer or chassis dealer service center.

The **F.I.N.** or *Fleetwood Identification Number* is located on the tag just outside the main entry door or on the outside left front side of the motor home. Use this number when ordering parts through your Fleetwood dealer or Service Center.

## CHASSIS AND VEHICLE IDENTIFICATION

(sample)

<b>FEDERAL CERTIFICATION TAG</b>		
MFG BY:	DATE OF MFR:	
INCOMPLETE VEHICLE MFG. BY:	DATE OF INC. VEH. MFR:	
GAWR:	KGS (	LBS)
GAWR FRONT:	KGS (	LBS)
	WITH:	RIMS
	TIRES AT:	KPA COLD SINGLE
	(	PSI)
GAWR INTERMEDIATE:	KGS (	LBS)
	WITH:	RIMS
	TIRES AT:	KPA COLD DUAL
	(	PSI)
GAWR REAR:	KGS (	LBS)
	WITH:	RIMS
	TIRES AT:	KPA COLD SINGLE
	(	PSI)
GAWR COMBINED INTERMEDIATE AND REAR: KGS ( LBS)		
This vehicle conforms to all applicable U.S. Federal Motor Vehicle Safety Standards in effect on:		
V.I.N. _____		
TYPE VEHICLE: MULTI-PURPOSE PASSENGER VEHICLE		
The tires on this unit may be different from those shown above. Check tire sidewalls for maximum inflation pressure.		
Replacement tires must be rated no less than the axle capacity (GAWR).		
W15-0002		

Located in the motor home driver compartment.

(sample)

<b>FLEETWOOD®</b>		
MOTOR HOMES		
OF		INC.
PLAN APPROVAL NO.		
F.I.N.		
MFD. ID. NO.	MODEL	
DATE OF MFR. MO:	YR:	

Located on the left of the main entry door or on exterior left front side of the motor home.

F.I.N. (Fleetwood Identification No.)

V.I.N. (Vehicle Identification No.)

<b>VEHICLE IDENTIFICATION NUMBER</b>	
<b>BAR CODE</b>	

This tag is located on the left top of the instrument panel.



The front suspension and steering system of this vehicle was accurately aligned at the factory before delivery to the dealership. However, after you have fully loaded the vehicle according to your personal needs, have the alignment checked and adjusted, if necessary. To help prevent uneven tire wear, check the front-end alignment periodically.

***Please note that front-end alignment after retail delivery is the owner's responsibility and is not covered under the warranty.***

Excessive or abnormal tire wear may indicate worn or misaligned suspension or steering components, unbalanced tire(s) or some other tire/suspension problem.

Alignment can be affected by worn steering/suspension parts or road hazards such as hitting a curb, pothole, railroad track, etc. Improper alignment can cause tires to roll at an angle and wear unevenly. It may also cause the vehicle to "pull" to the right or left.

Out-of-balance tires will not roll smoothly and will cause annoying vibrations and uneven tread wear such as cupping or flat spots. If you see uneven tire tread wear or if the vehicle ride comfort decreases, the tires may need to be balanced.

See the ***Chassis Operator's/Owner's Guide/Manual*** for more information.

---

Fleetwood does not sanction or condone the installation of any steering aid device that is not approved by our chassis manufacturer's. Any add-on device of this type will likely void the chassis manufacturer's warranty on the item or items affected.

Any after-market steering aid device proposed for installation must be approved by ***Fleetwood Motor Home Product Engineering*** before considering it for any after-market installation on your motor home.

## SUSPENSION ALIGNMENT AND TIRE BALANCE

## AFTER-MARKET STEERING AID DEVICES

# **INTRODUCTION**

---

## **Vehicle Crash**

Like any other vehicle you may drive, your motor home can be involved in a vehicle crash, including a rollover. The motor home will be damaged and you and others can be injured or killed. Drive defensively at all times. **DO NOT** drive if you are tired, have been drinking alcoholic beverages, are under the influence of any controlled substance, or are taking any medication or drugs that may impair your sight, hearing, judgment or coordination. Pull off the road and park in a safe area until you can drive safely.

## **Vehicle Handling**

Your motor home is longer, wider and higher than a typical car or truck you may be accustomed to driving. Keep this in mind as you become familiar with driving your motor home. New motor home owners should take special care to learn the driving and handling characteristics of your vehicle in safe and familiar surroundings. The distribution of the weight of your motor home is designed so it will handle safely while being driven.

- » *When loading the motor home, balance the load front-to-rear and side-to-side.*
- » *Load and secure heavier items lower in the storage areas than lighter items.*

If you fail to properly load your belongings and supplies, you will defeat the load distribution design of the motor home, possibly leading to handling problems and a vehicle crash.

# **WARNINGS, TERMS AND CONCEPTS FOR SAFE OPERATION OF YOUR MOTOR HOME**

## Vehicle Response

When you, the driver, accelerate, brake or steer the motor home, it responds to these inputs. If you are faced with an emergency while driving, the way you respond to the emergency and the way the motor home responds becomes more critical. If you load, alter or maintain your motor home improperly, it will not respond as it did when you first received it in an unloaded condition.

***Improper loading, alteration, maintenance and improper driver responses to emergency conditions can lead to handling problems and vehicle crashes.***

## Vehicle Towing

Your motor home can be equipped with a hitch designed to allow you to tow vehicles or other loads behind your motor home. The maximum amount of weight your motor home can pull or stop is determined by the manufacturer of the chassis on which your motor home is built. Check the ***Chassis Operator's/Owner's Guide/Manual*** provided by the motor home chassis manufacturer for the limits on the weight you can tow.

If the ***Chassis Operator's/Owner's Guide/Manual*** does not provide information on towing weight limits, do not tow a load of more than 1000 pounds unless the towed unit has a properly installed and operating supplemental brake control system that operates with the brakes on your motor home.

- » You may be able to increase the weight of any towed load by properly installing on the towed load a supplemental brake control system that operates with your motor home's braking system. Even with additional brakes, you cannot tow more than the GTW or GCWR for the chassis under your motor home. Again, check the ***Chassis Operator's/Owner's Guide/Manual***.
- » You **CANNOT** increase the towed weight limit by changing the size of your hitch.
- » Properly load what you tow to avoid a vehicle crash.

# INTRODUCTION

---

- » **Do not** attempt to tow something that is too heavy for your chassis.
- » **When driving in mountainous areas, look for and obey highway signs concerning grades and curves.** Your driving experience when pulling and stopping a towed unit on mountain roads will be very different from what you experience on level ground.
- » State laws in the United States and provincial laws in Canada are different concerning towing requirements and limits. Check the laws in the areas where you anticipate traveling.

## Alterations to Your Motor Home

Many motor home owners like to add a personal touch to their motor home. But there is a difference between changing how your motor home looks versus how it handles or responds to driver inputs. If you expect to make any type of alteration to your motor home, consult a professional who understands the correct way to do the alteration and how the alteration will change or affect the stability, handling, vehicle response, and overall performance and safety of your motor home. ***An improper alteration that affects vehicle handling or response can cause a vehicle crash, and any improper alteration to the electrical or LP gas systems can cause a fire and can endanger your motor home and its occupants.*** Fleetwood and your chassis manufacturer stand behind the motor home as delivered - **NOT** as altered by someone else.

## **Maintenance**

It is your responsibility to properly maintain your motor home. Consult your Fleetwood and *Chassis Operator's/Owner's Guide/Manual* for service information. See an authorized Fleetwood dealer to have your motor home serviced or repaired. You, or an experienced professional, should check all fluid levels and change fluids and filters when needed. Tire condition and proper inflation pressure is critical to safe operation. Keep your vehicle properly maintained to help avoid a vehicle crash.

## **Warning Devices**

Your motor home is equipped with warning devices. Check them before a trip for proper operation. A disabled warning device cannot warn you or your occupants of a life-threatening danger. Keep them working and respond to them quickly.

**This page intentionally blank.**

---

# ***DRIVER'S CONTROLS***

**This page intentionally blank.**

# DRIVER'S CONTROLS – CHEVROLET CHASSIS

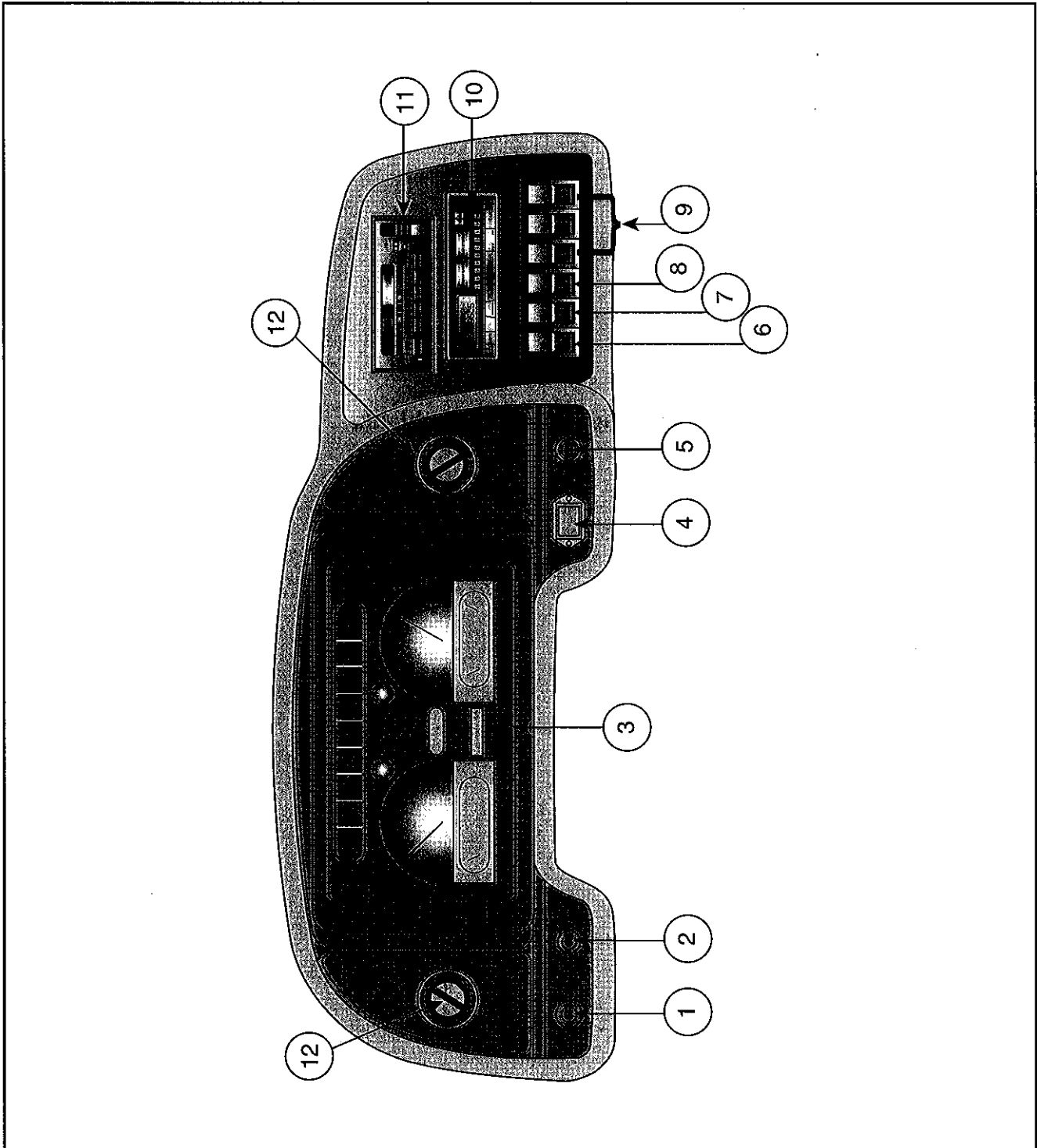



**1. Headlight Switch**

**Windshield Wiper/Washer** (some chassis) on turn signal stem

2-Speed Windshield Wiper/Washer with Delay – Turn knob clockwise for wiper action.

OFF – No wiper action.

1st notch – Wiper delay ON. Turn outer knob clockwise for longer delay between wiper strokes.

2nd notch – Slow wiping action.

3rd notch – Fast wiping action.

To WASH – Press inner knob then release. One press of the washer knob cycles wipers once. The washer nozzles are located on the wiper arms close to the wiper blades and move with the blades to provide continuous washer coverage.

**2. Auxiliary Start Switch**

The Auxiliary Start System allows you to use the coach battery to start the motor home engine if the chassis battery is discharged.

To use the system, push and hold the button and turn the ignition key to start the engine. Release the button and key switch when the engine starts.

If both the chassis and coach batteries are dead, the engine will not crank. Sufficient cranking charge may be restored to the coach batteries by plugging in to an external 120-volt AC electrical source or by running the generator.

The Auxiliary Start System has no effect on the vehicle except to aid in starting the motor home engine. If the vehicle alternator is operating properly, the batteries will be recharged while driving (see **Electrical System** chapter).

*Note: If extended normal driving does not recharge the batteries, see an authorized Fleetwood motor home service center.*

**3. Instrument Cluster – (Consult Chassis Operator's/Owner's Guide/Manual for details on instruments.)****4. Generator Hour Meter****5. Cigarette Lighter****6. Generator Start Switch****7. Radio Mode Switch** – Switches power to the radio between the chassis battery and the coach battery.**8. Hood Light Switch****9. Switch Blank** (3 available for future use)**10. Radio/Cassette Player****11. Cab Heater / A/C Controls** – (driver/cockpit area only)

**Temperature Control Lever** – Adjusts the temperature of the air coming out of the outlets. Move the lever to the left for cooler, and the right for warmer.

**Fan Speed Switch** – Turns the fan ON and OFF, and adjusts the fan speed.

**Air Intake Button (RECIRC)** – Selects the source of the air being warmed or cooled. When the button is pressed IN (RECIRC), interior air is recirculated through the system. When the button is OUT, air from outside the vehicle is drawn through the system. Normally, set the button OUT to circulate fresh air from outside. The RECIRC mode may be used when you desire faster cooling or heating, or if outside air is unusually dusty or odorous.

**Air Flow Control Buttons** – Directs the air to the desired outlets.

**VENT** – When this button is pushed, either warmed or cooled air comes out of the adjustable dash mounted outlets.

**B/L** – Bi-level. Air comes out of both the dash and floor outlets.

**FLOOR** – Air comes out of the floor outlets, with some air directed to the windshield to prevent fogging.

**DEF** – Air comes out of the windshield outlets to defrost the windshield. Set the fan switch to HI and the temperature lever to the far right for maximum defrosting.

**Air Conditioning (A/C) ON-OFF Button** – Turns air conditioning compressor ON and OFF. When air conditioning is desired, press this button IN and set the fan switch to any position except OFF.

**A/C Indicator Light** – This will light when the A/C button is ON. In the defrost (DEF) mode, the compressor will come on whether or not the A/C ON-OFF button is on. This helps to reduce the moisture in the air going to the defroster outlets.

**12. Vent Port**

**Remote Heater Mirror Switch** (left side of the instrument housing) (optional)

**Heater Switch** – Turns heat ON and OFF at both mirrors.

**Mirror Switch** – Select right/left mirror and movement of mirror(s).

# DRIVER'S CONTROLS – FORD CHASSIS

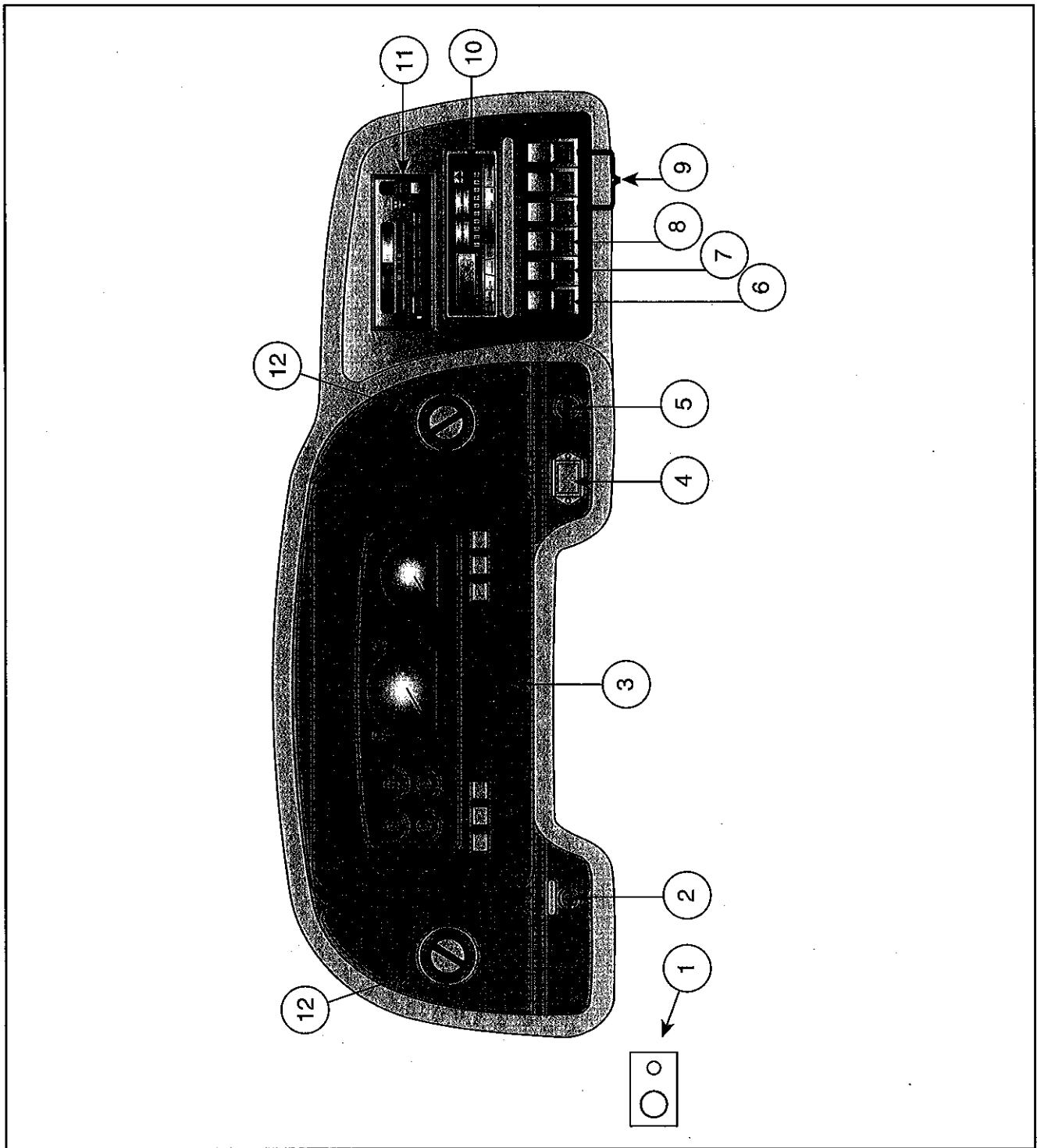

## 1. Headlight Switch

**Windshield Wiper/Washer** (*some chassis*) on turn signal stem

2-Speed Windshield Wiper/Washer with Delay – Turn knob clockwise for wiper action.

OFF – No wiper action.

1st notch – Wiper delay ON. Turn outer knob clockwise for longer delay between wiper strokes.

2nd notch – Slow wiping action.

3rd notch – Fast wiping action.

To WASH – Press inner knob then release. One press of the washer knob cycles wipers once. The washer nozzles are located on the wiper arms close to the wiper blades and move with the blades to provide continuous washer coverage.

## 2. Auxiliary Start Switch

The Auxiliary Start System allows you to use the coach battery to start the motor home engine if the chassis battery is discharged.

To use the system, push and hold the button and turn the ignition key to start the engine. Release the button and key switch when the engine starts.

If both the chassis and coach batteries are dead, the engine will not crank. Sufficient cranking charge may be restored to the coach batteries by plugging in to an external 120-volt AC electrical source or by running the generator.

The Auxiliary Start System has no effect on the vehicle except to aid in starting the motor home engine. If the vehicle alternator is operating properly, the batteries will be recharged while driving (see **Electrical System** chapter).

*Note: If extended normal driving does not recharge the batteries, see an authorized Fleetwood motor home service center.*

## 3. Instrument Cluster – (*Consult Chassis Operator's/Owner's Guide/Manual for details on instruments.*)

### 4. Generator Hour Meter

### 5. Cigarette Lighter

### 6. Generator Start Switch

### 7. Radio Mode Switch – Switches power to the radio between the engine battery and the coach battery.

### 8. Hood Light Switch

### 9. Switch Blank (*3 available for future use*)

## 10. Radio/Cassette Player

### 11. Cab Heater / A/C Controls – (*driver/cockpit area only*)

**Temperature Control Lever** – Adjusts the temperature of the air coming out of the outlets. Move the lever to the left for cooler, and the right for warmer.

**Fan Speed Switch** – Turns the fan ON and OFF, and adjusts the fan speed.

**Air Intake Button (RECIRC)** – Selects the source of the air being warmed or cooled. When the button is pressed IN (RECIRC), interior air is recirculated through the system. When the button is OUT, air from outside the vehicle is drawn through the system. Normally, set the button OUT to circulate fresh air from outside. The RECIRC mode may be used when you desire faster cooling or heating, or if outside air is unusually dusty or odorous.

**Air Flow Control Buttons** – Directs the air to the desired outlets.

**VENT** – When this button is pushed, either warmed or cooled air comes out of the adjustable dash mounted outlets.

**B/L** – Bi-level. Air comes out of both the dash and floor outlets.

**FLOOR** – Air comes out of the floor outlets, with some air directed to the windshield to prevent fogging.

**DEF** – Air comes out of the windshield outlets to defrost the windshield. Set the fan switch to HI and the temperature lever to the far right for maximum defrosting.

**Air Conditioning (A/C) ON-OFF Button** – Turns air conditioning compressor ON and OFF. When air conditioning is desired, press this button IN and set the fan switch to any position except OFF.

**A/C Indicator Light** – This will light when the A/C button is ON. In the defrost (DEF) mode, the compressor will come on whether or not the A/C ON-OFF button is on. This helps to reduce the moisture in the air going to the defroster outlets.

## 12. Vent Port

**Remote Heater Mirror Switch** (*left side of the instrument housing*) (*optional*)

**Heater Switch** – Turns heat ON and OFF at both mirrors.

**Mirror Switch** – Select right/left mirror and movement of mirror(s).

**This page intentionally blank.**

---

# ON THE ROAD

As the operator of this motor home, you are responsible for its proper and safe loading. This section is intended to provide you with helpful information concerning the loading of your motor home.

Your motor home chassis is designed to carry a specific maximum weight. This weight includes everything: the weight of the empty motor home itself, all occupants and their belongings, fuel, fresh water, waste water and anything else that may be in or attached to the motor home. ***This weight must never be exceeded.*** If you do exceed this weight, you will change how your motor home handles and responds, possibly leading to a vehicle crash.

## MOTOR HOME LOADING

### RESPONSIBILITY FOR PROPER LOADING

Before discussing loading and weighing, we need to explain some common weight terms. We will use abbreviations and you should refer back to these terms if you do not understand what the abbreviation means.

### SOME DEFINITIONS FIRST

#### **GVWR (Gross Vehicle Weight Rating)\***

means the maximum permissible weight of this motor home. The GVWR is equal to or greater than the sum of the Unloaded Vehicle Weight plus the Net Carrying Capacity.

#### **GCWR (Gross Combined Weight Rating)\***

means the value specified by the motor home manufacturer as the maximum allowable loaded weight of this motor home with its towed trailer or towed vehicle. Towing and braking capacities may be different. Refer to Fleetwood and the chassis manufacturer's manuals for complete information.

---

**\*These ratings are shown on the Carrying Capacity label.**

## ***ON THE ROAD***

---

### **GTW (Gross Towed Weight)\***

means the maximum permissible loaded weight of a trailer or car that this motor home has been designed to tow. This cannot be increased by changing the trailer hitch.

### **GAWR (Gross Axle Weight Rating)\***

means the maximum permissible loaded weight a specific axle is designed to carry.

### **TW (Tongue Weight)\***

the maximum permissible downward force exerted on the hitch ball by the towed vehicle coupler.

### **UVW (Unloaded Vehicle Weight)\***

means the weight of this motor home as built at the factory with full fuel, engine oil and coolants. The UVW does not include cargo, fresh water, LP gas, occupants, or dealer installed accessories.

### **NCC (Net Carrying Capacity)\***

means the maximum weight of all occupants including the driver, personal belongings, food, fresh water, LP gas, tools, tongue weight of towed vehicle, dealer installed accessories, etc., that can be carried by this motor home. Normal variation of materials may cause the Net Carrying Capacity to be 200 lbs. higher or lower than stated. (NCC is equal to or less than GVWR minus UVW.)

### **Designated Seating Capacity (Canadian units only)**

the number of sleeping positions designated equals the seating capacity.

When you use your motor home to tow, remember that you must stop the towed load with your motor home's brakes. This is critical on hills and in the mountains where you may encounter sharp curves and possibly irregular road surfaces. Check your motor home *Chassis Operator's/Owner's Guide/Manual* for the maximum weight your motor home can pull and stop on both level and steep roads. If the *Chassis Operator's/Owner's Guide/Manual* does not provide information on towing weight limits, do not tow a load of more than 1000 pounds unless the towed unit has a properly installed and operating supplement brake control system that operates with the brakes on your motor home. The supplemental brakes will NOT allow you to tow more than the listed GCWR for your motor home. ***If you cannot stop, you will crash.***

You must not exceed the weight factors listed below if you expect to tow something behind your motor home, either with or without a dolly. The factors are:

- » ***GCWR - Gross Combined Weight Rating***
- » ***GTW - Gross Towed Weight***
- » ***TW - Tongue Weight***
- » ***GAWR - Gross Axle Weight Rating***

The ratings for these factors are all listed on the carrying capacity label posted inside the motor home.

## TOWING A VEHICLE OR TRAILER

(“TOWED LOAD OR  
TOWED UNIT”)



### NOTE

Some states and provinces require brakes and safety chains on towed vehicles. Consult the proper authorities in the states or provinces through which you will be traveling.

## ON THE ROAD

---

If you expect to tow with your motor home, there are additional guidelines that you must follow:

- » ***Do not use a load equalizing hitch. It could cause structural damage to the motor home frame components.***
- » ***Limit the tongue weight to the Towed Weight as listed on the carrying capacity label. Heavier tongue weights can change your vehicle's handling and response, can cause a vehicle to crash, and will restrict your coverage under the Ownercare Warranty.***
- » ***Do not tow anything weighing more than the GTW listed on the carrying capacity label. Heavier towed loads can exceed your chassis' ability to pull and stop the load and cause a vehicle crash, damage the motor home structure or drive train, and restrict your coverage under the Fleetwood or chassis manufacturer's warranty. Changing the trailer hitch will not increase the tow capacity of the motor home.***
- » ***Consult the Chassis Operator's/Owner's Guide/ Manual, and U.S. state and Canadian provincial laws for towing weight limits and for guidelines for installing supplemental braking systems that operate with your motor home's brakes.***

The way your motor home handles and responds will be affected by the way the towed unit is loaded. If the tongue weight is too light in relation to the GTW, handling and response will change and your motor home will operate less safely. Careful load planning and safe experimentation with different loading patterns in what you are towing can avoid this risk and make your driving and towing experience safer and more enjoyable.

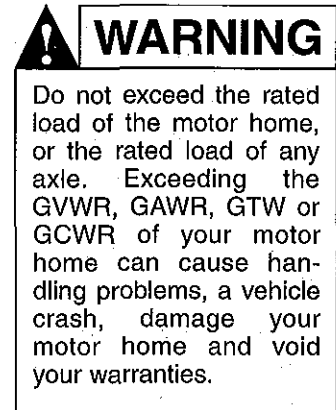



### CARRYING CAPACITY AND LOAD DISTRIBUTION

The amount of cargo weight you can place in your motor home is the motor home's GVWR *minus* its UVW, or maximum capacity *minus* the weight of your motor home as assembled by Fleetwood, *i.e.*, without dealer installed accessories, water, LP gas, cargo or occupants. When the motor home is being designed, the number and size of storage compartments, the liquid tank capacities and number of belted seating positions are determined for value and convenience. If you fill all liquid tanks to capacity, fill all storage compartments and cupboards to maximum volume and fill all available seating positions with passengers, the motor home could be overloaded. (See **Loading Tips**). Be aware of the weight of the items you store and where you store the items in your motor home, and weigh your motor home after it is fully loaded.

In addition to knowing the overall weight that can be safely loaded in or attached to the motor home, you must know how to distribute the weight so that correct amounts of weight are distributed between the axles or front-to-rear and also between the wheels or side-to-side. It is also important to place heavier items in under-the-floor storage or low in the motor home. If you make the motor home top heavy or much too heavy on one side, the motor home can be overturned and crash in a curve, turn or in an emergency steering maneuver. When the load is properly distributed, your motor home will handle and respond safely, and you as the driver can be more confident and will be more comfortable.

If your motor home is improperly loaded, it may be unsafe to drive, uncomfortable to drive, or both. Axle load is important and it is recommended that you should load your motor home so that the front axle is loaded to at least 80% of the front GAWR.



#### NOTE

*Net Carrying Capacities (NCC) of your motor home are specified on a label affixed to the inside of the motor home. The label includes all factory installed options. If other equipment such as leveling jacks, awnings, roof pods, etc., are installed after the motor home leaves the factory the weight of these items must be subtracted from the total of the passenger and cargo carrying capacities.*

## CARRYING CAPACITY

PRODUCT	YEAR	MODEL	SERIAL NO.
GVWR			LBS.
GCWR			LBS.
FRONT GAWR			LBS.
REAR GAWR (Includes capacity of tag axle if so equipped.)			LBS.
HITCH RATING _____ LBS.	TONGUE WEIGHT _____ LBS.	GTW _____ LBS.	
UVW (DRY WEIGHT) OF FINISHED VEHICLE			LBS.
NET CARRYING CAPACITY			LBS.

**GVWR (Gross Vehicle Weight Rating):** means the maximum permissible weight of this motor home. The GVWR is equal to or greater than the sum of the Unloaded Vehicle Weight plus the Net Carrying Capacity.

**GCWR (Gross Combination Weight Rating):** means the value specified by the motor home manufacturer as the maximum allowable loaded weight of this motor home with its towed trailer or towed vehicle. Towing and braking capacities may be different. Refer to Fleetwood and the chassis manufacturer's manual for complete information.

**GAWR (Gross Axle Weight Rating):** means the maximum permissible loaded weight a specific axle is designed to carry.

**GTW (Gross Towed Weight):** means the maximum permissible loaded weight of a trailer or car that this motor home has been designed to tow. This cannot be increased by changing the trailer hitch.

**Tongue Weight:** The maximum permissible downward force exerted on the hitch ball by the towed vehicle coupler.

**UVW (Unloaded Vehicle Weight):** means the weight of this motor home as built at the factory with full fuel, engine oil, and coolants. The UVW does not include cargo, fresh water, LP gas, occupants or dealer installed accessories.

**NCC (Net Carrying Capacity):** means the maximum weight of all occupants including the driver, personal belongings, food, fresh water, LP gas, tools, tongue weight of towed vehicle, dealer installed accessories, etc., that can be carried by this motor home. Normal variation of materials may cause the Net Carrying Capacity to be 200 lbs. higher or lower than stated. (NCC is equal to or less than GVWR minus UVW.)

This motor home is capable of carrying up to \_\_\_\_\_ gallons of fresh water (including water heater) for a total of \_\_\_\_\_ pounds.

Reference: Weight of fresh water is 8.33 lbs./gal.; Weight of LP gas is 4.5 lbs./gal. (average).

**WARNING: The Heaviest Loaded Motor Home With All Passengers, Goods, Water, Driver And Towed Vehicle Must Not Exceed Any Of The Following:**

1. The gross vehicle weight rating (GVWR).
2. The gross combination weight rating (GCWR).
3. The front/rear gross axle weight ratings (GAWR'S).

**CONSULT OWNER'S MANUAL FOR WEIGHING INSTRUCTIONS AND TOWING GUIDELINES.**

W15-2013 1095

Carrying Capacity Label

Refer to your local telephone directory to find a public weigh station. The following procedures will help you determine whether your loaded motor home (complete with cargo, fluids, passengers, and driver) is within GAWR, GVWR, and GCWR limits. When you arrive at a weigh station, the attendant will guide you through the correct positioning of the motor home on the scales.

1. Center the front wheels on the scale platform and take a reading. This is the front Gross Axle Weight (Reading 1).

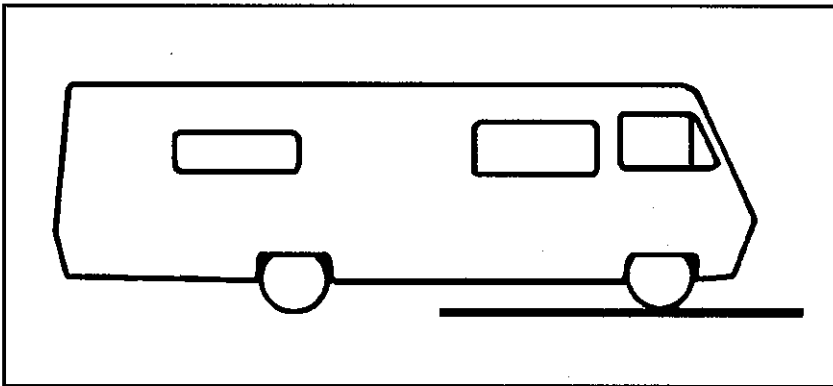

2. Center the entire motor home (all axles) on the scale and take a reading. This is the Gross Vehicle Weight (Reading 2).

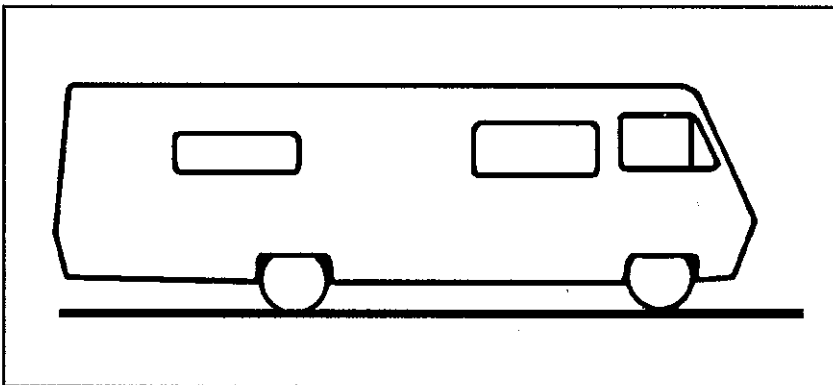

### **HOW TO WEIGH YOUR LOADED MOTOR HOME WITHOUT A TRAILER OR OTHER TOWED LOAD**

# ON THE ROAD

- Center the rear axle (or both rear axles if your motor home is equipped with tag axles) on the platform and take a reading. This reading is the rear Gross Axle Weight (Reading 3).

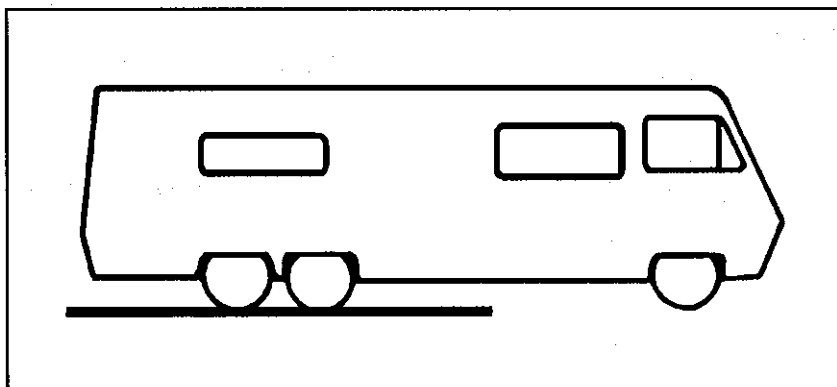

Compare the readings taken on the scales to the weight ratings on the Federal certification tag and carrying capacity label. Fill in the chart to aid in comparing weights.

If any readings are higher than the rating, you will have to adjust or remove the load.

MOTOR HOME READINGS (from labels)		SCALE READINGS
GVWR _____	<b>MOTOR HOME</b>	Reading 2 _____
Front GAWR _____	<b>FRONT AXLE</b>	Reading 1 _____
Rear GAWR _____	<b>REAR AXLE(S)</b>	Reading 3 _____
Hitch Rating _____	<b>TOWED VEHICLE</b>	Reading 4 _____
GCWR _____	<b>COMBINED VEHICLES</b>	Add 2 and 4 _____

1. Center the front wheels on the scale platform and take a reading. This is the front Gross Axle Weight (Reading 1).

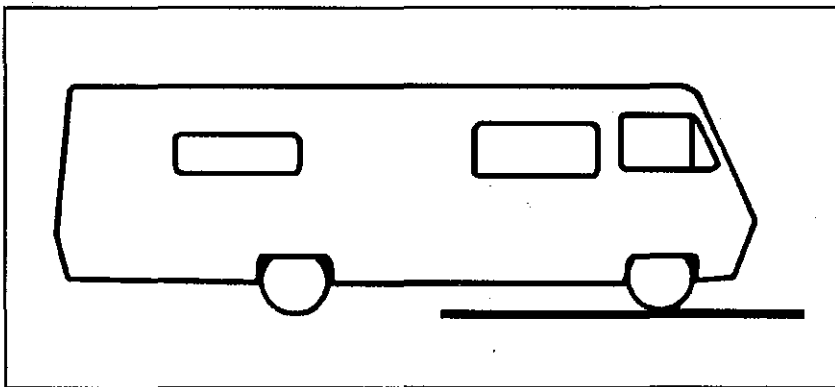

2. Center the entire motor home so that only the motor home is being weighed. Leave the towed load hitched to the motor home, but resting off of the scale. This is the Gross Vehicle Weight (Reading 2).

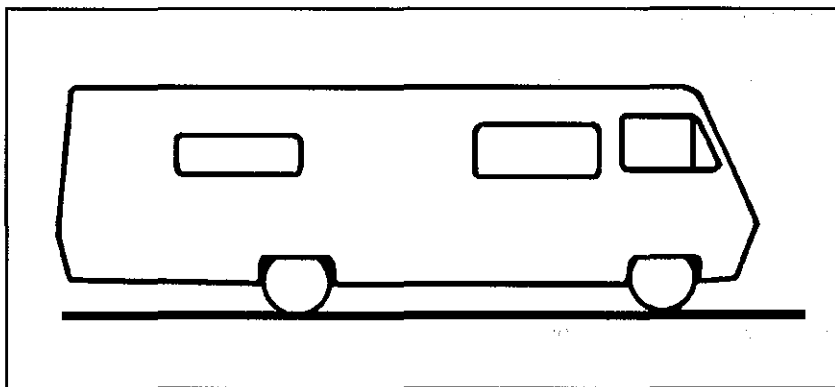

### ***HOW TO WEIGH YOUR LOADED MOTOR HOME WITH A TRAILER OR OTHER TOWED LOAD***

## ON THE ROAD

---

3. Center the towed load on the scale and take a reading. This is the Towed Vehicle Weight (Reading 4).

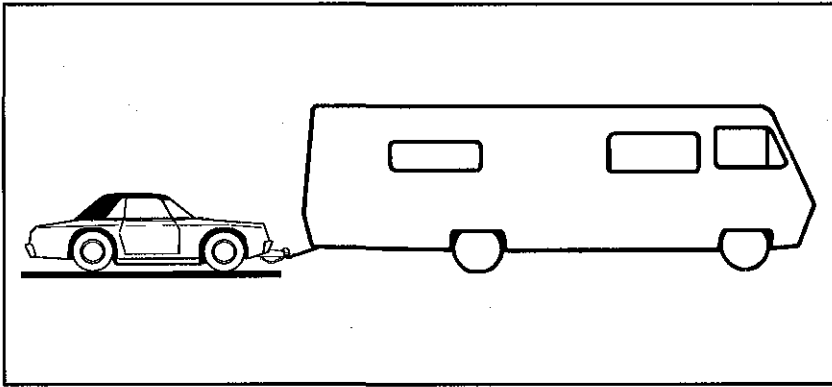

4. Subtract Reading 1 from Reading 2. This is the rear Gross Axle Weight (Reading 3).

Compare the readings taken on the scales to the weight ratings on the Federal certification tag and carrying capacity label. Fill in the chart to aid in comparing weights.

If any readings are higher than the rating, you will have to adjust or remove the load.

If you exceed weight ratings, you will:

- » *Cause unsafe braking.*
- » *Cause unstable driving and handling characteristics.*
- » *Cause damage to the motor home, drive train, or chassis.*
- » *Reduce your warranty protection.*

Since you may load your motor home differently for different trips, loading and weight patterns will change. Periodically reweigh your motor home and log the weights in this chapter. Refer to your log as you prepare to load for future trips.

- » *Load heavier items lower.*
- » *Do not load heavy items on the bumpers.*
- » *Make a loading diagram of your properly loaded motor home, and then weigh the properly loaded motor home. The loading diagram, your loading log and the loaded motor home weight will help you locate where specific items are stored, and will help speed the loading process.*
- » *Secure and brace items so they won't move during travel.*
- » *Fresh water and waste water weigh over eight pounds per gallon. Carry only as much water as needed for travel use or to balance the load, and whenever practical, empty the holding tanks before traveling.*
- » *Store emergency items in a readily accessible location. As a minimum include a fire extinguisher, tools, first aid kit, rain gear, flashlight, highway warning devices, an electric cord with light, and sturdy gloves.*

### LOADING TIPS

 **WARNING**

Modification of your vehicle by addition of racks not originally equipped by the manufacturer to carry additional equipment, vehicles or cargo will reduce your warranty coverage and may cause personal injury or property damage.

 **WARNING**

Do not store or carry LP gas containers, gasoline, or other flammable liquids inside your motor home.

---

Your motor home is equipped with wheels and tires selected to match the capacity specifications of the chassis as designed by the chassis manufacturer. Under normal circumstances and with proper tire and chassis maintenance, you should receive thousands of miles of trouble-free service.

### TIRES

## ON THE ROAD

---

For safety and maximum tire life, vehicle speeds must be proper, proper inflation pressure must be maintained, and tread depth and wear must be monitored. Properly inflated tires also contribute to overall motor home stability and safety. Refer to the tire section in your *Chassis Operator's/Owner's Guide/Manual* or any tire manufacturer's information that may be provided in your *Owner's Information Package* for information on maintenance and tire care.

The maximum inflation pressures are stated on the Federal Certification Tag located on the sidewall near the driver's seat. To maximize tire performance, consult with the tire manufacturer's guidelines or *Chassis Operator's/Owner's Guide/Manual* for recommended tire inflation pressure.



### NOTE

The tire pressures on your motor home were adjusted for the weight of the motor home at the time it was built. These pressures may be lower than the pressures required for the weight of a loaded motor home. Check and adjust the tire pressures on your motor home before your first trip using the information provided in the *Chassis Operator's/Owner's Guide/Manual*.



### NOTE

Check the wheel lug nut tightness periodically. They could work loose during driving. Check the *Chassis Operator's/Owner's Guide/Manual* for correct lug nut torque and torquing procedure.

## TIRE INFLATION



### WARNING

For safety and maximum tire life, check tire pressures often (including the spare, if equipped). Pay special attention to inside rear duals. Always check pressure when tires are cold, and do not bleed air out of warm tires. Follow the tire pressure instructions in the *Chassis Operator's/Owner's Guide/Manual* or the tire manufacturer's information.

Replacement tires must be the same size, type and tread depth per axle, and have at least the same weight carrying capacity as the original equipment. All tires of the same size and rating may not have the same weight carrying capacity. Consult your tire dealer. The original equipment wheels and tires supplied on your motor home have weight carrying capacities to support Gross Axle Weight Ratings (GAWR) as stated on the Federal Certification Tag located on the sidewall near the driver's seat.

## TIRE REPLACEMENT



In case of sudden tire failure:

- » **Remove your foot from the accelerator.**
- » **Use moderately heavy brake pedal pressure. Do not pump the brake. The vehicle is equipped with Anti-lock Brakes (ABS) which will properly control braking.**
- » **Firmly hold the steering wheel while avoiding abrupt steering inputs and move slowly to a safe, off-road place.**
- » **Park on a firm level surface.**
- » **Turn off the ignition.**
- » **Set the parking brake.**
- » **Turn on the hazard flasher system.**
- » **Ensure your passengers are safely located and children monitored.**
- » **Get professional help.**

### IF YOU GET A FLAT TIRE

---

Even with good tire maintenance and normal driving, you may experience a flat tire. Summon professional help through your auto club, travel service, or a local truck service facility. Your motor home is not equipped with a jack or other lifting device. Do not attempt to lift the motor home with a jack. Consult the *Chassis Operator's/Owner's Guide/Manual* for additional information on tire inflation and proper torque.

### CHANGING A FLAT TIRE

 **WARNING**

Truck wheels and tires are extremely heavy and may weigh 100 pounds or more. Do not attempt to remove the spare tire unless you are capable of handling the weight.

 **WARNING**

To avoid personal injury and/or property damage if a blowout or other tire damage occurs, obtain expert tire service help. Do not attempt to change the tire yourself.

## ON THE ROAD

---

Seat belts help to restrain you and your passengers in case of a collision. In most states, the law requires their use.

Seat belts provide the best restraint when:

- » *the seat back is upright*
- » *the occupant is sitting upright (not slouching)*
- » *the lap belt is snug and low on the hips*
- » *the shoulder belt is snug against the chest*
- » *the knees are straight forward*

For your safety, your vehicle has combination lap and shoulder belts for the driver and front seat passenger and lap belts without retractors in all other designated seating positions.

Always drive and ride with your seatback upright and the lap belt snug and low across the hips to reduce the risk of serious injury to the abdomen or neck that could be caused by sliding under the safety belts in a collision.

Never let a passenger hold a child on his or her lap while the vehicle is moving. The passenger cannot protect the child from injury in a collision.

Children should always ride with the seatback in the fully upright position. When the seatback is not fully upright, there is a greater risk that the child will slide under the safety belt and be seriously injured in a collision.

Never use a single belt for more than one person or across more than one seating position. This greatly increases the risk that one or both of the people will be injured in a collision. Each designated seating position in your vehicle has a specific seat belt assembly which is made up of one buckle and one tongue that are designed to be used as a pair.

## SEATS AND SEAT BELTS

 **WARNING**

Make sure that you and your passengers, including pregnant women, wear safety belts. Be sure that lap belts fit snugly and as low as possible around the hips. If safety belts are not used properly, the risk of you or your passengers being injured in a collision greatly increases.

 **WARNING**

Use the shoulder belt on the outside shoulder only. Never wear the shoulder belt under the arm. Never swing it around the neck over the inside shoulder. Failure to follow these precautions could increase the risk and/or severity of injury in an accident.

While your vehicle is in motion, the combination lap and shoulder belt adjusts to your movement. However, if you brake hard, corner hard or if your vehicle receives an impact, the lap and shoulder belt locks and prevents you from moving.

### *COMBINATION LAP AND SHOULDER BELTS*

To fasten the belt, pull the lap/shoulder belt from the extractor so that the shoulder portion of the belt crosses your shoulder and chest. Insert the belt tongue into the proper buckle until you hear a snap and feel it latch.

To tighten the lap portion of the belt, pull up on the shoulder belt until it fits you snugly. The belt should rest as low on your hips as possible.

A longer lap and shoulder belt assembly is available and is a direct replacement for the driver and front passenger positions. The longer lap and shoulder belt is made and tested to the same standards as the original belt. This belt assembly can be purchased and installed at any authorized Fleetwood motor home dealer.

---

Check your safety belt system periodically to make sure that it works properly and isn't damaged. If the webbing shows any wear, nicks or cuts, have it examined by a qualified technician to determine if replacement is necessary. Always have your safety belt system checked after a collision.

### *SAFETY BELT MAINTENANCE*

---

In most states, you are required by law to use safety restraints for children. If small children (less than four years old, and under 40 pounds) ride in your vehicle, you must put them in safety seats that are made specially for children. Safety belts alone do not provide maximum protection for these children. Check your local and state laws for specific requirements.

### *SAFETY RESTRAINTS FOR CHILDREN*

	<b>WARNING</b>
Never leave a child unattended in your vehicle. Always remove the key from the ignition and take it with you.	

# ON THE ROAD

---

Safety belts and seats can become hot in a vehicle that has been closed up in sunny weather, and could burn a small child. Check seat covers and buckles before you place a child anywhere near them.

Children who are too large for child safety seats should always wear safety belts.

If the shoulder belt cannot be properly positioned so that it does not cross or rest in front of the child's face or neck, move the child to one of the seats with a lap belt only and use the lap belt.

Lap belts and the lap portion of lap and shoulder belts should always be worn snugly and below the hips, touching the child's thighs.

Children should always ride with the seatback in the fully upright position. When the seatback is not fully upright, there is a greater risk that the child will slide under the safety belt and be seriously injured in a collision.

Use a safety seat that is recommended for the size and weight of the child. Seat backs should be upright for use with child safety seats.

## ***SAFETY BELTS FOR CHILDREN***

 **WARNING**

If safety belts are not properly worn and adjusted as described, the risk of serious injury to the child in a collision will be much greater.

## ***SAFETY SEATS FOR CHILDREN***

 **WARNING**

Carefully follow all of the manufacturer's instructions that come with the safety seat that you put in your vehicle. Make sure that the shoulder belt (if provided at the seating position where the safety seat is being used) does not cross or rest in front of the child's face or neck. If you do not install and use the safety seat properly, the child may be injured in a sudden stop or collision.

 **WARNING**

When using any infant or child restraint system, it is important that you follow the instructions and warnings provided by the manufacturer concerning its installation and use. Failure to follow the restraint manufacturer's instructions could increase the risk or severity of an injury in the event of a collision or sudden stop.

Driving your motor home will be different from driving your family car or truck. Your motor home is large and heavy. You may have to adjust or learn new driving techniques to safely operate your motor home.

Downhill driving puts extra strain on many drivetrain components of your motor home. The brakes are easily overloaded and overheated when used for downhill slowing. Brake fade will occur if the brakes overheat.

When driving down long grades, shift the transmission to a lower gear at the top of the grade. Rule of thumb: *Use the same lowest gear going down as it took to go up the hill.* Crest the hill in the lower gear. Monitor your speed.

Be cautious when maneuvering to allow for the length and width of the vehicle. Always allow room to corner and to change lanes. Your vehicle's side view mirrors and rear view camera monitor (if equipped) will help you keep aware of your vehicle's position and the position of other vehicles and/or obstructions near your motor home. You must monitor them constantly while you are driving. Become familiar with the operation of the side mirrors and learn to use them to view objects and the road beside and behind the motor home.

The rear view mirrors are controlled from a panel located on the driver's left side instrument panel. To adjust the mirrors, select either LEFT or RIGHT mirror and press the appropriate arrow. Activate the mirror heaters (if equipped) by pressing the HEATER position.

Remember that your motor home is heavier than a car, making it less maneuverable and harder to stop. Also, because of its greater side surface area, it is more easily affected by cross winds. Allow extra distances for passing and stopping, and drive at a moderate speed, particularly in traffic and in gusty wind conditions.

## DRIVING AND VEHICLE CONTROL

### MANEUVERING IN TRAFFIC



#### NOTE

*Although your motor home is equipped with power steering, the front wheels may be difficult to turn when at a dead stop. When maneuvering in some close situations, give yourself some room to move either forward or backward. The vehicle has to be in motion for the front wheels to be turned with ease.*

## ***ON THE ROAD***

---

Driving on winding or mountain roads is not difficult if done with reasonable care. Observe proper vehicle speeds when ascending or descending hills and always operate in the proper transmission range. Downshift on hills to avoid overheating or undue engine loads. Downshift when descending grades.

Engine compression and friction will help control vehicle speed, and relieve some of the strain on the brakes. Shift the transmission to a lower gear before starting down the grade.

Mountain driving or desert temperatures can put extreme demands on drive train components. Under extreme heat conditions you may need to turn off the vehicle air conditioner to improve engine and transmission cooling.

Be aware of the extra height of your motor home. Check for low hanging tree branches or other obstructions whenever you drive or park. Avoid low overhangs when pulling in for service. Always check overhead clearances of overpasses and bridges. ***This may be particularly important if you drive with the overhead vents open or if the motor home is equipped with a roof air conditioner, roof rack, CB or TV/radio/satellite antenna.***

Before leaving on a trip, check your route. Some tunnels prohibit motor homes with LP gas systems.

When parking parallel to a curb, be sure to allow for poles or obstructions as the front and rear portions of the motor home swing wider than an automobile. When parking on an incline, turn the front wheels into the curb in the direction of the roll to aid the parking brake. When parking, always shift the transmission to P and set the parking brake.

If you can't avoid operating, parking or idling your vehicle off-road:

- » *Be aware that combustible materials could catch fire from the vehicle's hot exhaust system.*
- » *Avoid driving your vehicle through or over combustible materials such as leaves, grass, vegetation or stubble high enough to touch, catch or collect on its hot exhaust system.*
- » *Parking or idling should be done only in an area where there are no combustible materials under the vehicle.*

	<b>WARNING</b>
Do not park or idle the motor home over combustible materials such as tall grass or dried leaves. Combustible materials may catch fire from the hot exhaust gases, soot or sparks that could escape through corrosion holes or cracks. This is particularly important if the exhaust system has not been properly maintained.	

To use the engine as a braking force, select the next lower gear. Engine braking provides good speed control for going down grades. When the motor home is heavily loaded, or the grade is steep, preselection of a lower gear prior to the grade may be desirable.

***Gear preselection*** means the selection of a lower gear to match the driving conditions you encounter or expect to encounter. Preselection will give you better control on slick or icy roads and on downgrades. Downshifting to lower gears increases engine braking. The selection of a lower gear often prevents cycling between a gear and the next higher gear on a series of short up-and-down hills.

---

### ***USING THE ENGINE TO SLOW THE MOTOR HOME***

## ***ON THE ROAD***

---

If your motor home is equipped with rear view video monitor, the camera is located at the top rear of the motor home. The rear view picture is displayed on a screen in the driver's compartment. The monitor screen may be overlaid with a distance scale reference which gives approximate distance of objects to the rear of the motor home.

### **To operate the video monitor:**

1. Turn on the ignition switch.
2. Shift the transmission to R.

To override normal operation, the ignition switch must be on and power must be on at the monitor.

Using the video monitor will take practice. Always allow more space for maneuvering until you are comfortable with the system. Check the side-mounted mirrors often while driving and especially during lane changes and when backing up.

The camera lens is exposed to road dirt and will get dirty. When necessary, clean the camera lens and monitor screen with a quality glass cleaner and nonabrasive cloth or towel.

---

In keeping with good engineering practice, and to meet the requirements of chassis manufacturers, certain chassis and underbody components of your motor home have been coated with an undercoating material. This material is intended to assist in protecting these components from corrosion or other effects of weather and road conditions. Please be aware that certain areas of the motor home do not have undercoating applied.

## **REAR VIEW VIDEO MONITOR**

 <b>CAUTION</b>
The rear view video monitor system provides a general view of the road and objects to the rear of the motor home. Your perception of this view and the relationships of objects to the motor home and each other will be different from that seen in a rear view mirror. Light conditions and the adjustment of the screen controls will also affect your perception. Always use the side-mounted rear view mirrors with the video monitor system.

## **BODY UNDERCOATING**



See the *Chassis Operator's/Owner's Guide/Manual* in the *Owner's Information Package* for chassis fuel recommendations. The optional generator is designed to run on the same fuel as the chassis. Consult the generator operating instructions for special cautions about maintenance with different types of fuels.

Modern fuel systems may build up vapor pressure within the tank as the fuel warms during use or hot weather. Under certain conditions, sudden release of this pressure when removing the fuel cap can cause fuel to spray from the fill opening, creating a fire hazard.

To protect the fuel system from excessive pressure or vacuum, or from sudden release of pressure, replace lost or damaged fuel fill caps with caps of the same design which are available from your Fleetwood motor home dealer.

Clean up fuel spills immediately. Fuel spilled on the motor home could damage the exterior finish, and is a serious fire hazard.

Your motor home's automotive fuel and emissions systems are sophisticated and engineered to meet Federal and State emissions standards. They are sometimes sensitive to fuel types and blends, particularly fuels blended for certain altitudes and climates. Fuel suppliers provide customers with the correct fuel for their location and seasonal conditions. Sometimes, though, fuel blended for winter is supplied during summer months.

## FUEL AND FUEL SYSTEMS

	<b>WARNING</b>
When removing the fuel fill cap, rotate it slowly only far enough to allow the pressure to release. After any "hissing" sound stops, remove the cap completely.	

---

## FUEL TYPES AND VAPOR LOCK

## ***ON THE ROAD***

---

“Vapor lock” occurs when gasoline vaporizes, and vapor pockets block the flow of liquid fuel to the engine. If you experience engine stall or stutter, you may be experiencing vapor lock. If your engine and fuel system are properly tuned and maintained, you should not experience this problem. If vapor lock occurs, the fuel itself could be the cause. If at all possible, check with the service station operator as to the fuel blend before filling your fuel tank. If you purchase your fuel from nationally recognized fuel dealers, your chances of vapor lock can be reduced. If you store your motor home during the winter months, be aware that when you take the vehicle out of storage in the spring or summer, winter fuel may cause vapor lock until it is consumed.

---

When the engine is under load or requires maximum cooling, the engine fan turns faster. The fan may become noisy at high speed and when maximum cooling is required. High speed fan noise can sometimes be misinterpreted as transmission slippage. This is not the case. This fan noise indicates that the fan is doing what it is supposed to do. This noise is not a defect in the fan or the transmission.

### **ENGINE FAN**

---

Your motor home engine has been designed to conform to Federal and State emission requirements. To meet these requirements, engine operating temperatures are high. As a result, the engine and exhaust systems radiate a great deal of heat.

### **EXHAUST SYSTEM HEAT**

Special heat shields are built into your motor home to protect wiring and other components from possible heat damage caused by the exhaust system. Do not remove these shields, modify the exhaust system, or add additional equipment, such as wiring, plumbing, or other components, which will be effected by exhaust system heat.

Engine temperature gauges have been calibrated to indicate a midrange reading as the “normal” operating temperature. The reason for this is that many owners perceive 212°F as the boiling point. However, this is not the case in an engine with a pressurized cooling system and a coolant mixture of glycol and water. As a motor home owner, be aware that the gauge is intended to provide a warning of any rapid change in engine coolant temperature from the “normal” reading of the gauge rather than an absolute temperature reading.

## **ENGINE TEMPERATURE GAUGES**

Carbon monoxide is a colorless, tasteless, odorless gas. It is a by-product of the burning of fossil fuels (gasoline, LP gas, diesel fuel, etc.). The chassis and generator engines, furnaces, water heater, LP gas refrigerator and range in your motor home produce it constantly while they are operating. **CARBON MONOXIDE IS DEADLY.** Please read and understand the following precautions to protect yourself and others from the effects of carbon monoxide poisoning.

## **CARBON MONOXIDE SAFETY PRECAUTIONS**

Beware of the symptoms of exhaust gas (carbon monoxide) poisoning:

*Dizziness*

*Vomiting*

*Nausea*

*Muscular twitching*

*Intense headache*

*Throbbing in temples*

*Weakness and sleepiness*

*Inability to think clearly*

If you or others experience any of these symptoms, get out into fresh air immediately. If symptoms persist, seek medical attention. Shut down the unit and do not operate it until it has been inspected and repaired.

**! WARNING**

Do not under any circumstances operate any engine while sleeping. You would not be able to monitor outside conditions to assure that engine exhaust does not enter the interior, and you would not be alert to exhaust odors or symptoms of carbon monoxide poisoning.

**! WARNING**

Exhaust gases are deadly. Do not block the tailpipes, or exhaust ports, or situate the vehicle in a place where the exhaust gases have any possibility of accumulating either outside, underneath, or inside your vehicle or any nearby vehicles. Outside air movements can carry exhaust gases inside the vehicle through windows or other openings remote from the exhaust outlet. Operate the engine(s), carbon monoxide-producing systems or components only when safe dispersion of exhaust gases can be assured. Monitor outside conditions to be sure that exhaust continues to be dispersed safely.

## ON THE ROAD

---

Your motor home is equipped with a carbon monoxide (CO) detector/alarm. It is usually located in the main sleeping area.

If the indicator sounds, it is an indication that carbon monoxide gas is present. This may occur while idling in high traffic concentrations or in campgrounds where other vehicles as well as your motor home are contributing to the carbon monoxide level in the surrounding air. Sounding of the alarm does not indicate a faulty alarm. The detector is doing its job of warning you of potentially high concentrations of carbon monoxide. See the section on *Carbon Monoxide* in this manual.

Test the CO detector/alarm after the motor home has been in storage, before each trip, and at least once a week during use. Please refer to the operating instructions included in your *Owner's Information Package*.

## CARBON MONOXIDE DETECTOR/ ALARM

---

The only safe and approved towing methods are either an under reach wheel lift device, as installed on a minimum 3-ton tow truck chassis, or a flat bed trailer. Most tow truck operators willing and able to tow motor homes will be familiar with these devices. Be prepared to give the tow truck operator at least the following information when you call:

*Length and height of motor home*

*Chassis manufacturer*

*Gross vehicle weight rating*

When towing with an under reach lift device, the vehicle must be towed from the front, either on the rear wheels (if operational) or on a heavy duty dolly. Consult your *Chassis Operator's/Owner's Guide/Manual*. Contact the chassis assistance center prior to calling a tow company to receive tow instructions and possible assistance with coordinating the tow.

## EMERGENCY TOWING



### CAUTION

Do not tow the motor home from the rear. Towing from the rear will cause serious overloading of the front tires and suspension, possibly resulting in tire or front suspension failure. The rear frame extensions are not designed to withstand the load imposed by lifting from the rear.

To prepare your motor home for towing:

1. Secure any loose or protruding parts of the disabled vehicle.
  2. Secure any heavy, loose items in the interior.
  3. Turn off LP gas appliances and the LP gas tank valve.
  4. Do not allow any person to ride in the towed vehicle.
- 

Structural members are located specifically to mount and attach factory-installed components and accessories, and may not be located to support after-market accessories not specifically designed for use on or in your motor home.

Please consult with your dealer before attempting to install or mount accessories on the sidewalls of your motor home. Holes drilled in the sidewall may cause damage, and may affect portions of your warranty coverage.

## **ATTACHING ACCESSORIES TO YOUR MOTOR HOME**

**This page intentionally blank.**

# LIVING WITH YOUR MOTOR HOME

Controls for the optional (standard on slide-out models) leveling system are located to the left of the instrument panel. A detailed operating and maintenance guide is included in your *Owner's Information Package*. Read all instructions for this system carefully before operating the system.

## HYDRAULIC LEVELING SYSTEM

 **WARNING**

The leveling system is designed as a leveling system only. Do not use the system as a jack or with a jack.

The power entry step is controlled by the ignition switch and by a switch near the entry door. Power for the entry step is supplied by the coach battery. The battery must be connected for the step to operate as described below. The step has a "last out" feature. With the battery disconnect ON, turn the ignition switch OFF and open the door. The step will extend and lock in the OUT position. The step also has an *ignition override* feature. If the door is closed (as though ready to depart) with the step extended, the step will automatically retract when the engine ignition is switched ON. This prevents driving with the step extended. The switches operate the step according to the following table.

## POWER ENTRY STEP

 **WARNING**

Under certain conditions, the step may not extend using the last-out feature. Always look and be sure the step is extended before exiting the motor home.

Ignition Switch Position	Step Switch Position	Step Position/ Action
OFF	ON	Step extends and retracts as the door opens and closes.
OFF	OFF	Step is inactive. It will not move regardless of door movement.
ON	ON	Step extends and retracts with opening and closing of door.
ON	OFF	Step is retracted for all door positions. If step is extended when ignition is turned ON, step will retract.

 **WARNING**

If door is opened and closed without allowing the step to fully extend and lock in the out position, the step will retract and lock in the up position.

# Living With Your Motor Home

---

## ENTRY DOORS AND SCREENS

The main entry door uses a latching system similar to that used in automobiles. It has a secondary or safety latch as well as a primary latch. When closing the door, be sure to close it firmly to advance the latch past the safety position and engage the primary latch. This will ensure that the door is fully closed. **When traveling, always lock the deadbolt.**

The screen door may be separated from the main entry door by depressing the catch or releasing the magnet. A holdback mechanism can be used to secure the main door against the side of the motor home.

---

Windows in your motor home are slider type. Open slider windows by operating the locking lever and sliding the window.

Any ventilating window may permit water inside. This water must be trapped and drained to the outside.

On your ventilating windows, water is trapped by the frame. During a heavy downpour, water may be seen in the lower portion of the frame. The sloping sill and weep slots allow the water to drain to the outside. These weep slots must be kept open.

*If water collects in the bottom channel and overflows, check the weep slots for debris and obstructions.*

**Read and understand these instructions before you need to use them.** The emergency exit window provides an emergency means of escape if the motor home doors are blocked or disabled for any reason or in case the motor home must be evacuated under emergency conditions. The emergency exit window is marked with a red latch.

## WINDOWS



### NOTE

*Screens are not removable for cleaning. They may be pushed out of their frames if the window must be used for emergency exit. In this case, the screens will be destroyed and will probably have to be replaced.*

## EMERGENCY EXIT WINDOW



# **Living With Your Motor Home**

---

Controls for the exterior rear view mirror adjustment and heater (if equipped) are located on the instrument panel.

## **REMOTE MIRROR CONTROL**

To adjust the mirrors, select either LEFT or RIGHT mirror and press the appropriate arrow. Activate the mirror heaters by pressing the HEATER position.

---

Sun visors at the driver and passenger positions swing down and are adjustable to provide relief from glare and bright sun.

## **SUN VISORS**

---

### **To raise mini-blinds:**

Release bottom of blind from retainer.  
Pull straight down on cord and release at desired height.  
It is not necessary to pull the cord to one side or the other to secure blind.

## **WINDOW SHADES**

### **To lower mini-blind:**

Pull straight down on the cord slightly, and move it about 45 degrees to either the left or right and lower the blind.  
Stop the blind in mid-travel by moving it back to the straight down position.  
Reattach the retainers when traveling.  
To adjust the angle, turn the adjusting rod either direction.

---

The day/night shades are dual-purpose window covering that provide privacy at night and light control during the day.

## **DAY/NIGHT SHADES**

To operate them, pull down on the lower bar to expose the sheer fabric for daytime light control. For use at night, pull on the upper bar to unfold the privacy curtain.

# ***LIVING WITH YOUR MOTOR HOME***

---

Exterior storage compartments maximize available space and should accommodate most of your storage needs. All of the storage compartments, except the LP gas and generator compartments, can be locked. Fire prevention regulations require that the LP gas and generator compartments be unlocked at all times.

Please note: Your motor home could be overloaded or out of balance if not properly loaded. Refer to the *Motor Home Loading* section of the *On The Road* chapter of this manual, and follow the loading and weighing instructions in that section. When storing equipment and supplies:

- »» Always keep tools and equipment stored in areas where they will not shift while traveling.
- »» Whenever possible, place heavy articles in storage compartments which are low and in the best location for better weight distribution. Pack articles carefully in the storage compartments to minimize shifting. If necessary, use straps to prevent movement.
- »» Be sure liquid containers are capped and cannot tip or spill. Secure all glass containers and dishes before traveling.
- »» Exterior storage compartments may not be watertight in all climate conditions. Carry any articles which could be damaged by water inside the motor home.

---

The closets and cabinets have friction catches along one edge of the door. Overhead doors may have supports to hold them open. Drawers rest in notches when they are closed. To open drawers, lift up slightly, then pull open.

## **STORAGE**

### ***EXTERIOR COMPARTMENTS***



#### **WARNING**

Do not store flammable, volatile liquids or hazardous chemicals inside the motor home or in outside storage compartments. Toxic fumes from these liquids or chemicals may enter the interior of the motor home.

### ***INTERIOR STORAGE***

Closets may be equipped with 12-volt lights that turn ON when the closet door is opened. Be sure the light goes OFF when the closet door is closed—your battery will be discharged if it stays ON. If the light stays on when the door is closed, the door switch requires adjustment. The same loading considerations apply to interior storage areas as to exterior. Consult the *Motor Home Loading* section in the *On The Road* chapter.

The materials used inside your motor home have been selected for durability and comfort. With reasonable care, these materials will stand up under years of recreational living. The *Maintenance* chapter in this manual outlines care requirements for the various upholstery fabrics, floor, cabinet, and wall finishes.

## INTERIOR AND FURNISHINGS

### To convert the dinette into a bed:

1. Unfasten and remove cushions.
2. Remove front and rear dinette seat rails.
3. Reach under the table. Either remove leg or fold it up under the table top.
4. Raise the front portion of table several inches to disengage inserts from the wall supports.
5. Lower table top to the dinette frame to complete bed base.
6. Slide seat and back cushion into place over bed base.

### DINETTE CONVERSION

### To convert a sofa/lounge into a bed:

1. Lift front of sofa frame up and out.
2. Push the back of the sofa back and down.
3. Push the seat belts through the space between the sofa back and seat.

# ***Living With Your Motor Home***

---

## **To restore the sofa/lounge:**

1. Pull the seat belts back up through the space.
2. Lift the front edge of the sofa frame up, and push it back.
3. The sofa back will come up.
4. Push the sofa into position.

Both decorative and 'utility' style 12-volt or 120-volt lighting fixtures may be used in your motor home. Utility style fixtures may be either single or dual. A slide switch selects either single or dual brightness. For your convenience, some lights are operated from wall switches. Clean the lenses with soapy water.

The bathroom lights are installed over the medicine cabinets and are switched by a wall-mounted switch.

## ***INTERIOR LIGHTING***



### **CAUTION**

Some of the lighting fixtures may be equipped with halogen bulbs. The bulbs and fixtures may get very hot when they are on. Do not touch these lighting fixtures when they are on. Allow them to cool before attempting to replace a bulb.

# ***LIVING WITH YOUR MOTOR HOME***

---

Overhead vents are located in the galley and bathroom areas for fresh air circulation and exhausting heat, odors and water vapor.

## ***OVERHEAD VENTS***

Turn the crank in the center of the vent to open and adjust. Some vents may also be equipped with a 12-volt fan. A switch controls fan operation. Be sure to turn the fan OFF before closing the vent.

Close the vents or lower them before traveling to avoid damage from wind and low overhead clearances.

The vent may be cleaned from the top of the motor home. Use soapy water on the vent cover. The screens may be vacuumed or lightly brushed to remove accumulation of leaves or other debris.

Lubricate the gears and mechanism yearly with a light, water resistant grease.

---

In some models, loose folding chairs are provided for your convenience. The chairs are stored on racks located in an interior rear storage compartment. Store loose chairs when traveling to avoid personal injury or damage.

## ***FOLDING CHAIRS***

# Living With Your Motor Home

---

The monitor panel allows you to conveniently check the approximate levels in the water tanks and to check battery condition(s).

Electrical probes installed in the tanks measure the levels at various points in the tanks.

## To check tank levels:

Press LP GAS, FRESH WATER, GRAY or BLACK TANK switches.

The E or empty indicator light will always be lit when the rocker switches are depressed. If the tank is full, all lights will be on. Lights are sequential, and indicate level in approximately ¼-tank increments. If the tank selected is approximately ½-full, for example, lights E, ¼ and ½ will be on.

## Erroneous tank level indications can be caused by:

- a. Water with low mineral content. The level is measured by a very low level electrical signal traveling through the liquid. Some water may not conduct the signal properly. This condition may be infrequent, but can exist. Check the panel reading when the fresh water tank is filled.
- b. Material trapped on the sides of the holding tanks may give a full reading when the tank is actually empty.

## To check the battery charge:

1. Unplug the 120-volt AC power cord to turn the power converter off.
2. Press BATTERY rocker switch on the panel.
3. Turn on a light or any 12-volt appliance. The battery must be checked with a load.
4. Read battery condition on the meter. Red is low, yellow is fair and green is good.

## MONITOR PANEL



### NOTE

*If the sensor probes mounted in the tanks get coated with grease, the monitor panel may indicate falsely or not at all. Avoid pouring grease, oils or similar substances down drains or the toilet. If this is unavoidable, the holding tank(s) should be washed out with a soapy water solution. See your dealer for additional information.*

# Living With Your Motor Home

---

Your RV was designed primarily for recreational use and short term occupancy. If you plan to stay in it for longer than a couple of days, you need to understand how to properly manage and control the humid conditions and condensation that you may experience.

Modern RVs are much smaller than a house, and are tightly built. This means that the interior air will become saturated with moisture more quickly. The routine activities of a few people can put a lot of water into the air. In cold weather, this moisture may become visible as condensation.

Condensation happens naturally. Just as moisture collects on the outside of a glass of cold water during humid weather, moisture can condense on the inside surfaces of your RV during cold weather when the humidity of the interior air is high.

Water vapor will condense on the inside of the windows and walls. In really cold weather, frost or ice may appear. ***It may also condense out of sight within the walls or the ceiling.*** If enough water collects in the wall or ceiling materials, it may cause water stains on the wall or ceiling surface. You might think that your walls or ceiling are leaking. You have a problem with condensation if you see these signs. You need to do something to reduce the moisture inside your RV.

If you locate your RV in an area that experiences cold winter temperatures, you may experience the effects of condensation. Even though you can't eliminate it completely, you can reduce or eliminate its effects.

## EFFECTS OF PERMANENT OCCUPANCY

### CONDENSATION AND HOW TO CONTROL IT



#### NOTE

Your RV is not designed to be used as permanent housing. Use of this product for long term or permanent occupancy may lead to premature deterioration of structure, interior finishes, fabrics, carpeting and drapes. Damage or deterioration due to long term occupancy may not be considered normal, and may under the terms of the warranty constitute misuse, abuse, or neglect, and may therefore reduce your warranty protection.

## ***Living With Your Motor Home***

---

Here are some frequently asked questions about condensation and some answers that will help you understand more about your RV and how to keep it comfortable.

**Q. – In cold weather, my windows and walls look like they're sweating. Is that condensation?**

**A. –** Yes. Your windows are a good way to know if the humidity in your RV is too high. All air contains water vapor. When air is warm it can hold much more water vapor than when it is cold. When the air cools, the water vapor "condenses" back to a liquid. Since your windows are usually cooler than the air, the water collects on the surface of the glass.

**Q. – Isn't my insulation supposed to keep my RV warm? Is something wrong with my RV?**

**A. –** Yes, your insulation is designed to keep your RV comfortable in cold weather. Not only do you have superior insulation, but your RV is tightly built to close manufacturing tolerances. Your RV really holds the air in.

And no, there is nothing wrong with your RV. Quite the opposite is true. Most homes have large cracks and spaces that allow moist air to escape to the outside. But the windows and doors in your RV are tightly sealed. Air just has a hard time getting through to the outside.

**Q. – Where does all the water come from?**

**A. –** Moisture in the air comes from many sources. Some of the most common are:

**Cooking** – Meals prepared for a family of four can add up to a gallon of water per day into the air from cooking.

**Bathing** – An average shower puts between  $\frac{1}{4}$  -  $\frac{1}{2}$  pounds of water into the air. It takes four tub baths to equal that amount.



## ***Living With Your Motor Home***

---

***Dishwashing*** – Doing the dishes for a typical day's meals can add up to one pound of water to the air.

***Floor mopping*** – When an 8' x 10' kitchen floor is mopped and rinsed, almost 2½ pounds of water are released in the air.

***Clothes drying*** – After 10 pounds of clothes have been washed and spin-dried in a washer, they still contain about 10 pounds of water. If these clothes are dried inside, that water is released into the air in the RV.

***Gas appliances*** – When gas is burned, carbon dioxide, nitrogen and water are given off into the air. For every 1000 cubic feet of gas burned, nearly 88 pounds of water is released into the air.

***Humidifiers*** – Humidifiers are designed to put moisture into dry air – up to two pounds per hour. So in a 24-hour period, an uncontrolled humidifier can put almost 50 pounds of water into the air.

***House plants and aquariums*** – Plants give off almost as much water as you put on them. And open aquariums permit higher rates of evaporation than closed types.

***People and animals*** – A large source of water in the RV is the inhabitants themselves. A family of four can put up to 12 pounds of water into the air per day through breathing and perspiration.

As you can see, just the normal course of living adds a great deal of water to the air.

### **Q. – What will all this water do to my RV?**

**A. –** The least it will do is fog your windows. If it is really cold outside, frost or even clear ice could form on the inside of the glass.

Excessive moisture in the air could show up as water running down or dripping off walls, ceilings or fixtures. It may look like your roof or windows are leaking. This water may stain woodwork, carpeting, ceiling panels or even furniture.

## ***Living With Your Motor Home***

---

But the most damage is caused by water you can't even see. Water will penetrate almost any material – except glass and metals. Water vapor in the air always wants to move toward dry air. Scientists call this “vapor pressure” action. It will go through walls, floor covering, plywood, paint – just about anything. The water that gets trapped in these materials can cause warping, mildew, paint failure and rotting.

The damage caused by excessive humidity can be invisible, and worse, expensive to fix. Please remember that this damage is not covered under the warranty.

### **Q. – What can I do to reduce or eliminate condensation problems in my RV?**

A. – The two most important things are:

*Reduce moisture released into the air  
and increase ventilation*

#### **To reduce moisture released inside the RV:**

1. Run the vent fan when cooking and the bath vent fan (or open the bath vent) when bathing. Avoid making steam from excessive boiling or use of hot water. Remove water or snow from shoes before entering to avoid soaking the carpet. Avoid drying clothes inside (except in the dryer, if equipped). The water drying out of the clothes goes into the air.
2. If you set up your RV in a semipermanent situation, cover the ground under it with a vapor barrier material.
3. Vent appliances to the outside. Your clothes dryer should always be vented according to the dryer manufacturer's installation instructions, if required. (Some dryers are designed to be ventless and do not require a vent to the outdoors.) Check the vents periodically to be sure they are not blocked.

## Living With Your MOTOR HOME

---

4. Avoid placing pans of water on the stove or in heat ducts to raise the humidity.
5. If you operate or use vaporizing inhalers, or similar devices, always provide adequate ventilation.
6. Never use open flame gas or kerosene-burning heaters indoors. These devices release water into the air, and the exhaust gases contain poisonous substances.

### To increase ventilation:

1. Use the kitchen and bath exhaust fans, if equipped, when cooking or bathing. Let them run for a while after a bath or meal.
2. Ventilate with outside air. Partially open one or more roof vents and/or windows to provide circulation of outside air into the interior. While this ventilation will increase furnace heating load, it will greatly reduce, or eliminate, condensation. Even when it is raining or snowing, outside air will be far drier than interior air and will effectively reduce condensation.
3. Avoid taping windows or doors tightly closed. This will prevent any air movement and will make the condensation problem worse.
4. Ventilate closets and cabinets. During prolonged use in very cold weather, leave cabinet and closet doors partially open to warm and ventilate the interiors of storage compartments built against exterior walls. The air flow will warm the exterior wall surface, and reduce or eliminate condensation, and prevent possible ice formation. Avoid crowding closets or wardrobe space. Overstuffed closets restrict air flow.
5. Stock kitchen and bath cabinets to allow free air circulation.
6. Open drapes over windows as often as possible and convenient.

 **CAUTION**

Do not heat the motor home interior with the range or oven. Open flames add moisture to the interior air. Do not use an air humidifier inside the motor home. Water put into the air by the humidifier will increase condensation.

 **WARNING**

Do not cover emergency exit window(s). This window must be left accessible at all times for emergency exit.

## ***Living With Your Motor Home***

---

7. Install a dehumidifier appliance. During prolonged, continuous use, a dehumidifying appliance may be more comfortable and effective in removing excess moisture from the interior air. Use of a dehumidifier is not a "cure-all." Ventilation and moisture reduction are the most effective ways to eliminate excess moisture. But operation of a dehumidifier will reduce the amount of outside air needed for ventilation. Heating load on the furnace will be reduced, and the interior will be less drafty.
8. Ventilate while driving. Positive air ventilation will help reduce the build-up of moisture while driving. The movement of the RV at highway speeds can draw air from the outside through the windows or vents.
9. Control the interior heat. If the heat is a dry heat, the humidity will tend to be lower. Here are some tips on controlling humidity with heat:
  - *Clean furnace air filters regularly to keep good air circulation.*
  - *Keep registers and the furnace blower clean and unobstructed. This helps air circulation.*
  - *Do not operate a humidity device on your furnace.*

---

During cold weather and even in short term occupancy, condensation frequently forms on ceiling vents and may even accumulate to the point of dripping onto the surfaces below. This is frequently misinterpreted as a "leaking" roof vent but is most often condensation drippage. Follow the preceding steps to control moisture condensation, and protect surfaces with plastic sheeting until the moisture has dissipated.

### ***DRIPPING CEILING VENTS***

# Living With Your Motor Home

---

The hazard and possibility of fire exists in all areas of life, and the recreational life-style is no exception. Your motor home is a complex machine made up of many materials, some of them flammable. But like most hazards, the possibility of fire can be minimized, if not totally eliminated, by recognizing the danger and practicing common sense, safety and maintenance habits.

The fire extinguisher furnished with your motor home is rated for Class B (gasoline, diesel fuel, grease, flammable liquids) and Class C (electrical) fires since these are the most common types of fires in vehicles. Read the instructions on the fire extinguisher. Know where it is located and how and when to use it. Remember that portable fire extinguishers are appliances intended for use by the occupants of a building or area that is threatened by fire. They are most valuable when used immediately on small fires. They have a limited amount of fire-extinguishing material, and therefore must be used properly so this material is not wasted.

Fire extinguishers are pressurized, mechanical devices. They must be handled with care and treated with respect. They must be maintained as outlined in any maintenance instructions provided with the device so they are ready to operate properly and safely. Parts or internal chemicals may deteriorate in time and need replacement. Always follow maintenance and recharging instructions provided by the fire extinguisher manufacturer.

## FIRE SAFETY



### WARNING

Urethane foam is flammable! Do not expose urethane foams to open flames or any other direct or indirect high temperature sources of ignition such as burning operations, welding, burning cigarettes, space heaters or unprotected electric light bulbs.

Once ignited, urethane foams will burn rapidly, releasing great heat and consuming oxygen very quickly.

In an enclosed space the resulting deficiency of oxygen will present a danger of suffocation to the occupants. Hazardous gases released by the burning foam can be incapacitating or fatal to human beings if inhaled in sufficient quantities.

## ***Living With Your Motor Home***

---

Explosive fuel clouds may be present at fuel filling stations.

Instruct occupants on what to do in case of fire, and hold fire drills periodically.

Maintain proper charge in the fire extinguisher.

If you experience a fire while traveling, ***maintain control of the vehicle until you can safely stop. Evacuate the vehicle as quickly and safely as possible.***

If you experience a fire while camped, ***evacuate the vehicle as quickly and safely as possible.***

Consider the cause and severity of the fire and risk involved before trying to put it out. If the fire is major or is fuel-fed, move away from the side of the LP gas tank, stand clear of the vehicle and wait for the fire department or other emergency assistance.

If your motor home is damaged by fire, do not drive or live in it until you have had it thoroughly examined and repaired.

### ***FIRE SAFETY PRECAUTIONS***

#### **WARNING**

Before refueling (either gasoline, diesel or LPG) be sure to turn off all pilot flames and appliances in your motor home. Turning off the propane at the tank is insufficient. Pilotless appliances may still spark or pilot flames may not extinguish immediately.

#### **WARNING**

Do not store or carry LP gas containers, or other flammable liquids inside your motor home.

## Living With Your Motor Home

---

The smoke detector/alarm is mounted on the ceiling in the living/cooking area of your motor home. It is powered by a 9-volt battery. Please read the smoke detector/alarm operating instructions for details on testing and caring for this important safety device.

### SMOKE DETECTOR/ ALARM

Test the smoke detector/alarm after the motor home has been in storage, before each trip, and at least once a week during use. The smoke detector/alarm should never be disabled due to nuisance or false alarm from cooking smoke, a dusty furnace, etc.

Ventilate your motor home with fresh air and the alarm will shut off. **Do not disconnect the battery.**

Replace the battery once a year or immediately when the low battery BEEP signal sounds.

If the smoke detector/alarm fails to operate with new batteries, replace it with a new unit, available through an authorized Fleetwood Service Center.

---

The slide-out room is designed to provide additional living space for site set-up.

### SLIDE-OUT ROOMS

There are two types of slide-outs available as standard or optional equipment on your motor home. A detailed operating and maintenance guide is included in your **Owner's Information Package**. Read all instructions for these systems carefully before operating the slide-outs.

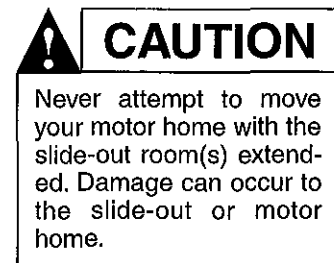

**This page intentionally blank.**



---

# ***PLUMBING SYSTEMS***

The plumbing systems in your motor home are constructed of thermoplastic materials. Holding tanks and piping components are strong, lightweight, and corrosion resistant.

Fresh water is available from either an external "city water" hookup or on-board storage.

## **FRESH WATER SYSTEM**

The external system is pressurized by the water system at an RV park or city water supply. The connection is located in the utility compartment on the rear left side of the motor home.

## **EXTERNAL FRESH WATER HOOKUP**

### **To connect to pressurized city water:**

1. Connect one end of a potable water hose to the RV park or city water supply. This will usually be a faucet or valve similar to your garden hose valve at home. Potable water hoses are available at RV supply stores.
2. Run the city water supply for a few seconds to clear the line. Turn off the water.
3. Attach the other end of the potable water hose to city water connection located inside the motor home utility compartment. Make sure all connections are tight.
4. Turn on the RV park/city water supply. Open all faucets inside the motor home to clear the lines. Then turn off faucets.

	<b>CAUTION</b>
Since water pressures at campgrounds vary, we recommend you install an in-line pressure regulator at the water supply faucet. This will protect the motor home water system and your supply hose from excessively high water pressure.	

# PLUMBING SYSTEMS

---

## To disconnect the city water:

1. Turn OFF the city water supply.
2. Remove the hose from the city water supply valve.
3. Drain and store the hose.

---

## The on-board fresh water tank can be filled in two ways: (1) city water pressure or (2) gravity.

1. City water pressure – When connected to the city water supply as described above, open the tank fill valve and remove the fresh water tank fill cap and vent plug.

Make sure the external gravity fill connection is open (remove the cap) to allow air to escape from the on-board tank. When water flows out of this external fill, the on-board tank is full.

After filling, close the valve, replace the tank fill cap and vent plug.

2. Gravity fill –The external gravity water fill is located on the exterior of the motor home. The on-board water tank can be filled here. To fill the fresh water tank, remove the cap, remove the vent plug, and fill the tank using a potable water hose.

Check the monitor panel often to determine if the tank is full. If water is flowing from the top vent, your tank is full. Stop filling. Replace the vent plug and filler cap.

## FILLING THE ON-BOARD WATER TANK

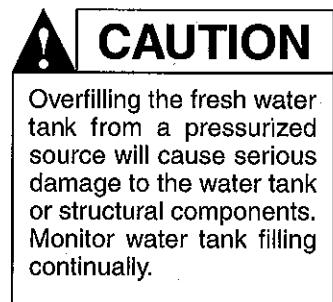

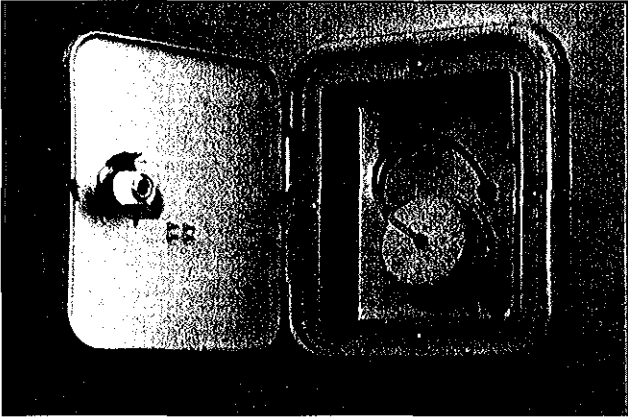

*Fresh Water Tank Fill*

Avoid leaving the water in the tank when the motor home is not in use. Turn the water pump OFF before draining the water tank. Whenever possible, drain the fresh water tank before traveling. Water in the tank will reduce the carrying capacity of the motor home. See *Motor Home Loading* section of the *On The Road* chapter.

The main water tank “quick-drain” valve is located on the end of the fresh water tank, in the water tank compartment.

The on-board fresh water system is pressurized by a self-priming, 12-volt DC pump. The pump operates automatically when the pump power switch is ON and a faucet is opened. When the faucets are closed, the pump shuts off. At free flow, the pump draws approximately 7 to 7½ amps. A 20-amp fuse at the converter panel protects the pump circuit. It can run dry for extended periods without damage. See *Electrical Systems* chapter.

Turn the pump master switch ON to pressurize the system. When a faucet is opened after the initial filling of the tank, the water may sputter for a few seconds. This is normal and is not cause for concern. The water flow will become steady when all air is bled from the water lines.

---

## *DRAINING THE FRESH WATER TANK*

---

## *WATER PUMP*

# ***Plumbing SYSTEMS***

---

Dirt, mineral scale, and organic matter are filtered out of the fresh water system by an in-line water filter on the inlet side of the water pump. If you suspect a clogged filter, it is easily removed and cleaned.

## ***WATER FILTER***

Inspect the filter after running the first full tank of water. Clean and inspect monthly thereafter.

1. Loosen the clamp at the inlet end of the filter.
2. Pull the water line off the filter.
3. Unscrew the filter from the water pump.
4. Turn each end of the filter and pull apart.
5. Flush out and clean screen.
6. Reverse procedure to install.
7. Operate the water pump and check for leaks.

---

### **To drain hot and cold lines:**

## ***LOW POINT DRAINS***

1. Open hot and cold valves at the external utility compartment.
2. Open the shower handle and faucet until all water has drained from the lines.

Water system problems usually fall into two categories: Inherent system problems, and problems caused by neglect. System problems are usually the result of road vibration and campsite water pressure variations. Problems of neglect usually stem from failure to clean filters, improper winterization, and poor battery maintenance. Most water system problems can be avoided by conscientious maintenance.

## TROUBLESHOOTING THE FRESH WATER SYSTEM

Vibration, flexing and twisting while traveling can work pipe fittings loose. Check all plumbing for leaks at least once a year. If the water pump runs when a faucet is not open, suspect a leak. Be sure the tank drain valves are tightly closed. Leaks occur most often around threaded fittings. If necessary, tighten or clean and tighten the fittings. Do not over-tighten fittings. Connections at galley and lavatory fixtures should not be tightened with a wrench. They will normally seal with hand-tightening. If a leak persists at one of the fittings, disconnect it completely and check for mineral deposits or other foreign matter at the seating surfaces. Clean the surfaces thoroughly and reinstall the fitting.

## LEAKS

Leaks caused by freezing damage can be prevented if you properly winterize the system. See the *Storage* chapter of this manual. Freezing damage is usually extensive and may include a burst water tank, split piping, and a damaged water pump, toilet, and water heater. If you experience this type of damage, repairs can best be made by an authorized Fleetwood dealer.

# Plumbing SYSTEMS

---

Sanitize the fresh water tank and piping approximately every three months, and whenever the motor home sits for a prolonged period. This will discourage the growth of bacteria and other organisms that can contaminate the water supply. Use a chlorine/fresh water rinse as follows:

1. Prepare a solution of ¼-cup household liquid chlorine bleach (5% sodium hypochlorite) to one gallon of water for each 15 gallons of tank capacity.
2. Close drain valves and faucets, pour the chlorine solution into the exterior fresh water tank filler spout, and complete filling with fresh water.
3. Turn water pump switch ON. (Be sure you have 12-volt DC power.) Open all faucets individually until water flows steadily, then turn them off. This will purge any air from the lines.
4. Top off water tank with fresh water and wait three hours.
5. Drain the entire system by opening all fresh water tank valves, faucets, and plumbing line drain valves.
6. Flush the system with drinking quality water. Let the fresh water flow through the system for several minutes to flush out the chlorine solution.
7. After you stop the flushing, close the tank valve, faucets, and drain valves. You can now fill the tank with fresh water, and the system is ready to use.

## SANITIZING THE FRESH WATER SYSTEM

A shower fixture is mounted in the exterior utility compartment. The water pump must be ON or city water pressure must be available for the shower to operate.

## EXTERIOR SHOWER

Water filter systems help provide consistent drinking water quality as you travel. A special filter is part of this system. The filter cartridge is located in the cabinet under the galley sink. Your *Owner's Information Package* contains detailed operating and maintenance instructions concerning this system.

## DRINKING WATER FILTER SYSTEM



### NOTE

If the refrigerator is equipped with an ice maker, the ice maker water is also filtered.

Please note that the special faucet at the galley is the only outlet for the filtered water. Although filtered water is not available at the standard galley and lavy outlets, the water available at these outlets is filtered by the water pump filter. Note also that this system is not designed for or effective in removing or neutralizing bacterial contaminants.

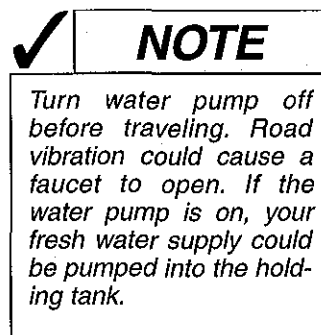

---

The waste water system in your motor home is made up of sinks, tub, shower, toilet, plumbing drain and vent lines, a *grey water* holding tank, and a *black water* holding tank.

## WASTE WATER SYSTEM

Generally, water from the sinks and shower drains into the grey water tank, the toilet drains into the black water tank. The holding tanks make the system completely self-contained and allow you to dispose of waste water at your convenience. A flexible sewer hose is required to connect the holding tank outlet to the inlet of an approved waste water dump station or sewer system.

The drain plumbing is similar to that used in your home. The system is trapped and vented to prevent waste gases from backing up into the motor home. The drain plumbing is made of ABS plastic, and is durable and resistant to most chemicals.

---

Your motor home is equipped with a marine-type toilet. Please follow the operating instructions found in your *Owner's Information Package*.

## TOILET

# Plumbing SYSTEMS

---

The holding tanks terminate in a valve arrangement that permits draining each tank separately or together.

The valves are called knife valves. A blade closes the opening in the sewer drain pipes. The blade is connected to a T-handle assembly mounted in the utility compartment. Pull the T-handle to release the contents of the tank(s).

During self-containment use, the sewer line is securely capped to prevent leakage of waste material onto the ground or pavement. ***Do not pull the holding tank knife valve open when the protective cap is installed on the pipe.*** Always drain the tank into an acceptable sewer inlet or dump station.

Whenever possible, drain the holding tanks before traveling. Waste water and sewage in the holding tanks reduce the carrying capacity of the motor home. See the ***Motor Home Loading*** chapter.

Drain the holding tanks only when they are at least  $\frac{3}{4}$ -full. If necessary, fill the tanks with water to  $\frac{3}{4}$ -full. This provides sufficient water to allow complete flushing of waste material into the sewer line.

During extended or semi-permanent hookups to sewage systems, waste materials will build up in the tank and cause serious plugging if the tank valves are continuously open. In these cases, keep the valves closed until the tanks are  $\frac{3}{4}$ -full, and then drain into the sewage system.

The holding tank drain valve outlet is to be used with a removable termination fitting that locks onto the outlet with a clockwise twist. Clamp the sewer drain hose to this fitting. A protective cap should remain in place when you are not draining the tanks.

## DRAINING THE HOLDING TANKS

	<b>WARNING</b>
Holding tanks are enclosed sewer systems and as such must be drained into an approved dump station. Both black and grey water holding tanks must be drained and thoroughly rinsed regularly to prevent accumulation of harmful or toxic materials.	



## To drain the holding tanks:

1. Attach the sewer hose to the holding tank outlet. Insert the end of the hose into the sewer or dump station inlet, pushing it firmly far enough into the opening to be secure. In some cases, adapters may be necessary between the line and the inlet.
2. Arrange the sewer hose so it slopes evenly.
3. Drain the black water holding tank first. Grasp the T-handle of the black water knife valve firmly and pull the valve open with a quick, steady pull.
4. Allow enough time for the tank to drain completely. Rinse and flush the tank through the toilet.
5. When the tank is empty, push the T-handle in to close the valve.
6. Run enough water into the tank to cover the bottom (up to 5 gallons). This will aid the break up of solid wastes and reduce "pyramiding" of waste material.
7. To drain the grey water tank, repeat the steps above. This tank is drained last to aid in flushing the outlets and hose. The grey water knife valve may be left open in a semi-permanent hookup.
8. Remove the sewer hose and cap the outlet.
9. Rinse out the sewer hose with fresh water and remove the sewer hose from the dump station.
10. Replace sewer or dump station covers.



### **NOTE**

*Local or state regulations may prohibit highway travel unless the holding tank outlet is securely capped.*

# PLUMBING SYSTEMS

---

The black water holding tank is equipped with rinsing spray heads that will aid in the removal of sewage residue from the interior of the holding tank. To operate the tank flushing system, follow the procedures for *Dumping The Holding Tanks* in this chapter. After dumping the gray water tank proceed as follows:

1. Connect a garden hose to the 6" stub hose with the quick connect coupler.
2. Insert the quick connect coupler into the flush inlet. This connection is labeled, "SEWER VALVE MUST BE OPEN WHEN USING THIS INLET."
3. Open the black water sewer valve. THIS VALVE MUST BE OPEN.
4. Open the water valve at the quick connect coupler and at the water supply.
5. Rinse the tank for 2-3 minutes or until the water is running clear from the sewer hose.
6. Turn off the fresh water and disconnect the hose.
7. After rinse water has thoroughly drained from the black tank close the knife valve and replace the termination cap. If you are parked at a site with a semipermanent sewer hookup, keep the black water knife valve closed to allow the waste level to build up. The outlet will probably clog if you leave the knife valve open continually. Run enough water into the tank to cover the bottom. This will aid the break up of solid wastes.

*Please...Practice good housekeeping when draining wastes at a campsite or disposal station. Leave the site in good order. Above all, do not pollute.*

## BLACK TANK FLUSH SYSTEM



### CAUTION

Do not use the same hose you use for filling the potable water tank, or for connection to the city water inlet. This is especially true if you the connect the quick connect hose to the typical rinsing hoses at most dumping stations. Use of a different hose will insure that you will not contaminate your fresh water supply.



### CAUTION

The sewer drain valve must be open when using the **SAN-T-FLUSH** inlet.

## *HOLDING TANK CARE*

Since holding tanks don't rely on any sophisticated mechanical devices for their operation, they are virtually trouble free. The most common problem is also an unpleasant one—clogging. You can minimize the chances of clogging by keeping the following considerations in mind:

- » Keep the black water tank knife valve closed. Fill tank to at least  $\frac{3}{4}$ -full before draining. Be sure to cover the tank bottom with water after draining.
- » Use only toilet tissue formulated for use in septic tank or RV sanitation systems.
- » Keep both knife valves closed and locked, and the drain cap tightly in place when using the system on the road.
- » Use only cleaners that are approved for use in septic tank or RV sanitation systems.
- » Use a special holding tank deodorant chemical approved for septic tank systems in the black water holding tank. These chemicals aid the breakdown of solid wastes and make the system much more pleasant to use. Do not put facial tissue, paper, ethylene glycol-based or other automotive antifreeze, sanitary napkins or household toilet cleaners in the holding tanks.
- » Do not put anything solid in either tank that could scratch or puncture the tank.

### **If the drain system does get clogged:**

- » Use a hand-operated probe to loosen stubborn accumulations.
- » Seriously clogged P-traps may require disassembly. Be careful not to overtighten when reassembling.
- » Do not use harsh household drain cleaners.
- » Do not use motorized drain augers.
- » Sometimes the holding tank valve will get clogged. In this case, a hand-operated auger may be necessary. Be ready to close the valve quickly once the clog is cleared. If the seal gets damaged, it is easily replaced.

# PLUMBING SYSTEMS

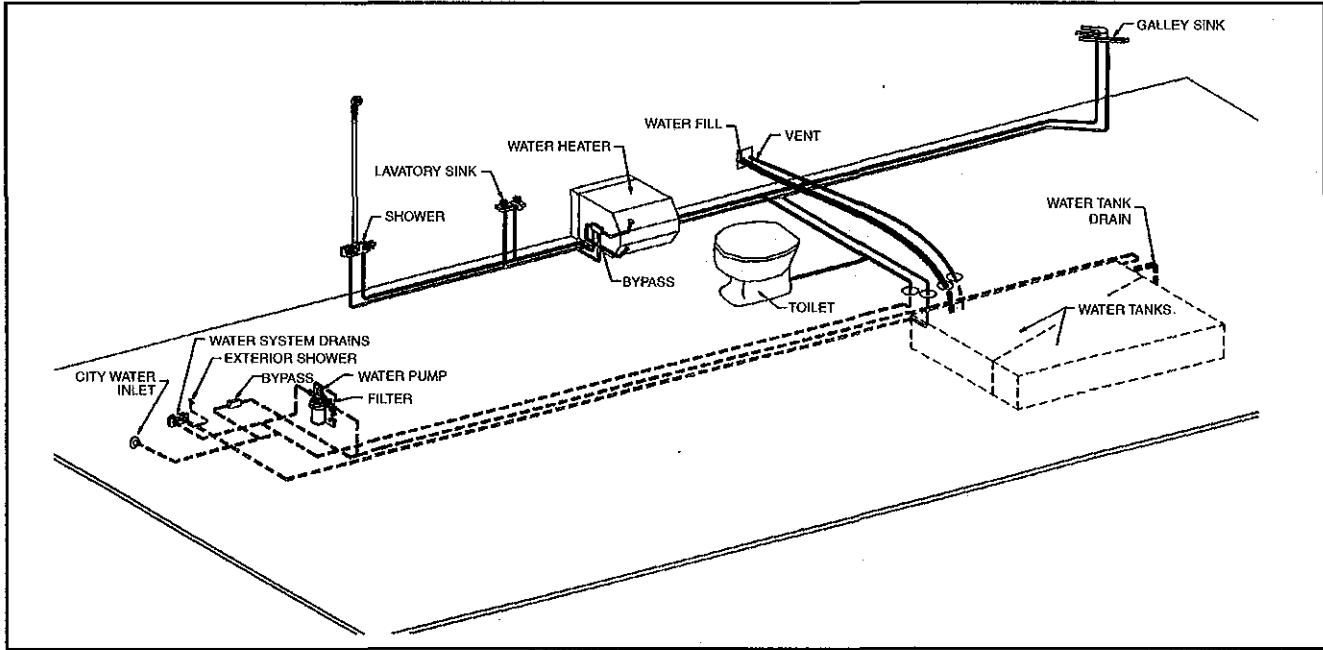

Typical Hot and Cold Diagram

The holding tank area is heated through special ducts from the furnace. To assure adequate heat is available to prevent holding tank freeze-up during extreme cold weather use, the furnace thermostat should be set no lower than 65 degrees if the outdoor temperature is 10 to 35 degrees. For temperatures lower than 10 degrees, set the thermostat 1 degree higher for each degree the outdoor temperature drops below 10 degrees. See the examples in the table below.

## EXTREME COLD WEATHER USAGE

Ambient (Outdoor) Temperature	Furnace Thermostat Setting
10° - 35°	65°
9°	66°
8°	67°
7°	68°
6°	69°
5°	70°

---

# ELECTRICAL SYSTEMS

Your motor home is equipped with three electrical systems:

*the chassis 12-volt system*

*the Fleetwood 12-volt house and automotive system*

*the 120-volt AC system.*

They operate together to give you electrical power for many different situations.

These electrical systems comply with all regulations, codes, and standards in effect at the time the motor home was built.

---

This is the chassis 12-volt or vehicle electrical system. It includes

*the vehicle battery*

*engine battery/house battery charging system*

*ignition system*

*instrument panel and controls*

*the headlights, taillights, turn signals*

*other vehicle lights and accessories.*

## CHASSIS 12-VOLT ELECTRICAL SYSTEM

Fuses will interrupt the flow of electricity if a circuit is overloaded. The 12-volt chassis fuse panel is located under the driver's side instrument panel. Additional fuses may be located under the hood, or in 12-volt power leads on the related equipment and accessories.

Exterior bulb types are listed in the *Maintenance* section of this *Owner's Manual*. Always replace bulbs and fuses with equivalent types and ratings.

## CHASSIS BULBS AND FUSES

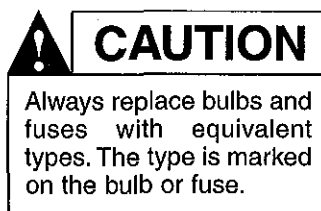

# ELECTRICAL SYSTEMS

---

This system includes

*all 12-volt interior lighting fixtures & outlets*

*fresh water pump*

*12-volt accessories.*

Special deep-cycle, high capacity house batteries provide 12-volt DC power. These batteries are not the chassis 12-volt batteries. Power is also provided by a DC converter that operates when the motor home main electrical cord is plugged into 120-volt AC power source. The house batteries are charged by the motor home engine alternator, the converter when it is operating, or the generator (if equipped).

## FLEETWOOD 12-VOLT HOUSE AND AUTOMOTIVE SYSTEM



### NOTE

Power for living area radios and tape decks is available from either the chassis or house batteries. A switch on the instrument panel allows you to select the power source. If you use the radio, tape decks, or other 12-volt DC equipment for long periods of time when the motor home engine is not running, either battery may be discharged.

Your motor home has two battery systems. One system supplies 12-volt DC power to start the vehicle engine and generator. The other system supplies 12-volt DC power to the house living area.

## BATTERIES

Some accessories or equipment such as clocks, radios or the refrigerator may draw small amounts of current even when turned OFF. A relay-operated disconnect system allows you to disconnect either the chassis battery or the coach battery or both. Disconnecting the batteries will help reduce the likelihood of battery discharge over long storage periods.

## BATTERY

## DISCONNECT



### NOTE

A troubleshooting guide and function manual that explains this system is included with your motor home **Owner's Information Package**.

If you plan to store the motor home for over ten days, press the disconnect switch/es to OFF. Remember to press the switch/es to ON when you take the motor home out of storage.



## NOTE

When charging the house batteries, the battery disconnect switch must be ON.

Check the external condition of the battery periodically. Look for cracks in the cover and case. Check the vent plugs and replace any that are cracked or broken. Keep the battery clean. Acid film and dirt on the battery top may permit current to flow between the terminals and discharge the battery.

## BATTERY INSPECTION AND CARE

### To clean the battery:

1. Be sure the vent caps are installed and tight.
2. Wash the battery with a diluted solution of baking soda and water to neutralize any acid present.
3. Flush with clean water. Foaming around terminals or on top of the battery is normal acid neutralization. Avoid getting the soda solution in the battery.
4. Dry the cables and terminals.
5. Do not use grease on the bare metal inside the cable terminals to prevent corrosion. Grease is an insulator. Electricity will not flow through it. A plastic battery terminal spray will protect the terminals after you have cleaned and reinstalled them.
6. Check the battery, including water level, at least once a week. Keep the carrier and hold down hardware clean and free of corrosion and chemical accumulation.



## WARNING

Do not use the motor home when the coach battery is disconnected. The power step will not operate as designed if the coach battery is disconnected. If the step is not in the correct extended position, you may be injured if you step out of the motor home.



## WARNING

Disconnect the 120-volt shore cord and the negative terminal from the coach battery/ies before working on either electrical system. If you work on the electrical systems with the power cord connected, you may be shocked, electrocuted, or severely burned.

# ELECTRICAL SYSTEMS

---

Both sets of batteries will be kept charged by the chassis engine alternator and charging system while you are driving. The DC power converter will charge the coach battery when plugged into 120-volt AC service. The batteries can also be charged by the generator. If the battery needs to be charged from a different charging source, please follow these safety guidelines:

- » Leaving a charger connected to a battery for an extended period of time can shorten battery life.
- » Do not smoke near batteries being charged or which have been recently charged. Please note that batteries are being charged while you drive, and while you are connected to 120-volt AC power through the converter/charger circuit.
- » Do not break live circuits at the terminals of the battery. Use care when connecting or disconnecting booster leads or cables. Attaching booster cables, and poor connections are a common cause of electrical arcs which can cause explosion.
- » Check and adjust the electrolyte level before charging. Fill each cell to the indicator with distilled water.
- » Always remove all vent caps before charging the battery.
- » Do not charge the battery at a rate that causes the electrolyte to spew out.
- » In cold temperature storage conditions, batteries may freeze if not kept properly charged.

## BATTERY CHARGING

### **WARNING**

Remove rings, metal watchbands, and other metal jewelry before working around a battery. Use caution when using metal tools. If a tool contacts a battery terminal or metal connected to it, a short circuit could occur which could cause personal injury, explosion or fire.

### **WARNING**

Do not allow battery electrolyte to contact skin, eyes, fabrics, or painted surfaces. The electrolyte is a sulphuric acid solution which could cause serious personal injury or property damage. Wear eye protection when working with batteries.

### **WARNING**

Never expose the battery to open flame or electric spark. Chemical action in the battery generates hydrogen gas which is flammable and explosive. Do not allow battery electrolyte (acid) to contact skin, eyes, fabrics, or painted surfaces.



## ***ELECTRICAL SYSTEMS***

---

When the battery requires replacement, always choose a battery with the same physical and electrical characteristics as the original equipment. Your dealer or an authorized Fleetwood Service Center can advise you on proper battery selection.

### ***SELECTING A REPLACEMENT BATTERY***

---

If your motor home is equipped with roof air conditioners, the front unit will have a solar panel. The solar charging panel is designed to “trickle-charge” your battery system. It is not intended to be a fast charger. It also cannot supply large amounts of current to operate 12-volt DC electrical equipment. When the sky is clear and under bright sun, the solar panel will help keep your batteries “topped-up.” Do not try to operate 12-volt DC appliances with the output of the solar panel. A light on the monitor panel indicates when the solar panel is operating.

### ***SOLAR PANEL***

The panel can be expanded with optional expansion panels. Contact your dealer for more information on these optional panels.

You can use the **Auxiliary Start System** to start the motor home engine with the coach battery if the chassis battery is discharged. The **Auxiliary Start System** has no effect on the vehicle except to aid in starting the motor home engine. If the vehicle alternator is operating properly, the batteries will be charged while driving.

### ***AUXILIARY START SYSTEM***

#### **To use the Auxiliary Start System:**

1. Be sure the motor home is stopped. Shift the transmission to **P** and apply the parking brake.
2. Press and hold the **Auxiliary Start** switch on the instrument panel.
3. Start the engine with the ignition switch.
4. Release the **Auxiliary Start** switch.

# ELECTRICAL SYSTEMS

---

This system provides grounded 120-volt AC electrical service for appliances such as air conditioners, TV, microwave ovens, etc. This system includes:

*the generator*

*the main electrical power cord ("shore cord")*

Your motor home is equipped with a heavy duty, 30-amp power cord. It is commonly called the "shore cord". This cord is used to connect to external 120-volt AC service. The cord and connector is molded together to form a weather-proof cable assembly. Do not cut or alter the cable in any way. Do not remove the ground pin in the cable connector, or defeat the ground circuit in the motor home.

To connect the power cord to external service, push the plug straight into the receptacle.

The converter will automatically supply 12-volt DC power when your motor home is operating on 120-volt from the generator or a public utility. It will also charge the coach and chassis batteries.

## 120-VOLT SYSTEM

### WARNING

Do not operate the 120-volt electrical system without a proper ground. Electrocution or severe electrical shock could result.

### CAUTION

Switch off the 30-amp main breakers located in the 120-volt AC load center (breaker panel) before you insert or remove the 30-amp power plug. Be sure to insert or remove the plug straight into or out of the receptacle. The neutral and both 120-volt pins should make contact at the same time to avoid excessive voltage on one leg of the circuit that could damage 120-volt appliances.

---

## POWER CONVERTER

Bathroom, galley, and patio 120-volt electrical outlets are protected by a **Ground Fault Circuit Interrupter (GFCI)**. This device is intended to protect you against the hazards of electrical shocks possible when using electrical appliances in the bathroom or galley or in damp areas. Should a circuit or appliance (electric shaver, hair dryer, etc.) develop a potential shock hazard, the GFCI device is designed to disconnect the outlet (and other outlets on the same circuit), limiting your exposure time.

### Test the GFCI at least once a month. To test the GFCI:

1. Connect the main power cord to 120-volt AC.
2. Push the **TEST** button. The **RESET** button should pop out, indicating that the protected circuit has been disconnected.
3. If the **RESET** button does not pop out when the test button is pushed, a loss of ground fault protection is indicated. Do not use any electrical outlets. Have the motor home electrical system checked at an authorized Fleetwood Service Center or by a qualified electrician. Do not use the system until the problem has been corrected.
4. To restore power push the **RESET** button.

Your *Owner's Information Package* contains a card that can be used to record test dates. Keep the card in a conspicuous place and keep it up to date.

## GROUND FAULT CIRCUIT INTERRUPTER (GFCI)



### NOTE

If an outlet doesn't work, check the GFCI. Reset it if necessary. If the GFCI continues to trip, have the motor home electrical system checked at an authorized Fleetwood Service Center or by a qualified electrician.



### WARNING

Do not install 12-volt fuses or 120-volt breakers with amperage ratings greater than that specified on the device or label. Doing so constitutes a fire hazard.

# ELECTRICAL SYSTEMS

---

Your motor home may be equipped with a gasoline powered generator. It will provide complete electrical self-containment when regular public utility AC power is unavailable, or use of the inverter is not practical. Controls are located at the generator and at a remote control panel located on the instrument panel.

With the generator operating, power is available at all of the 120-volt power outlets in the motor home, just as if the main power cord were connected to an external source. The generator is also connected to the power converter, and will supply 12-volt DC power as well.

Fuel for the generator is taken from the main fuel tank through a special feeder tube which is higher in the tank than the feeder tube to the motor home engine. This arrangement prevents the generator from running the motor home fuel tank dry.

## To start the generator:

1. Press **START** switch until generator is running.
2. To stop the unit, hold the switch in the **STOP** position until the engine stops completely. If you release the switch too soon, the engine will continue to run.

If the generator is slow to start, **DO NOT** hold the switch in the **START** position for more than 10 seconds. Release the switch, wait 15 seconds, then try to start again. This will help avoid overheating and damage to the generator starting system.

 **WARNING**

Do not operate the generator when parked in or near high grass or brush. Exhaust heat may cause a fire.

## GENERATOR

 **WARNING**

Do not under any circumstances operate the generator while sleeping. You would not be able to monitor outside conditions to assure that generator exhaust does not enter the interior, and you would not be alert to exhaust odors or symptoms of carbon monoxide poisoning.

## GENERATOR FUEL SUPPLY

## GENERATOR OPERATION

 **NOTE**

Refer to the generator operating instructions provided in your **Owner's Information Package** for information before starting the generator. Do not start the generator unit with a heavy power load. Always wait at least three minutes after starting generator before turning on (or plugging in) heavy electrical loads, such as the roof air conditioner.

Read and understand the generator operating, maintenance and safety instruction furnished in your *Owner's Information Package*.

- » Do not smoke or use an open flame near the generator unit or fuel tank.
- » Do not use generator ventilation air for heating any interior living space. Ventilating air can contain high concentrations of deadly gases, including carbon monoxide.
- » Check engine fuel lines often. Fuel leakage in or around the compartment is an extreme fire hazard. Do not use the generator until fuel leaks are repaired.
- » Be aware of exhaust gas (carbon monoxide) poisoning symptoms. Refer to the section on **Carbon Monoxide Safety Precautions** in the *On The Road* chapter.
- » Check the generator exhaust system after every eight hours of operation and whenever the system may have been damaged, and repair any leaks or obstructions before further operation. Disconnect the battery before performing any maintenance on the generator. Allow the generator to cool before performing any maintenance.
- » Do not use the generator as an emergency power source to a general residential or industrial utility line. This is illegal and may cause shock or electrocution to power line utility personnel attempting to repair power lines

## GENERATOR OPERATING SAFETY PRECAUTIONS

 **WARNING**

Do not block the generator ventilating air inlets or outlets. The engine requires a constant supply of cooling air. Restricted ventilating air inlets or outlets can cause engine failure or fire from engine overheating.

 **WARNING**

Exhaust gases are deadly. Inspect the generator exhaust system thoroughly before starting the generator engine. Do not block the tail pipe or situate the motor home in a place where the exhaust gases have any possibility of accumulating either outside, underneath, or inside your vehicle or any nearby vehicles. Outside air movements can carry exhaust gases inside the vehicle through windows or other openings remote from the generator exhaust. Operate the generator only when safe dispersion of exhaust gases can be assured, and monitor outside conditions to be sure that exhaust gases continue to be dispersed safely.

 **WARNING**

Do not modify the generator installation or exhaust system in any way.

 **WARNING**

Do not place flammable material or store any other materials in the generator compartment.

## ***ELECTRICAL SYSTEMS***

---

The dual air conditioners are controlled by the Electronic Climate Control system. This system allows both automatic and manual control of the rooftop air conditioners and the furnace(s) in your motor home.

The system will automatically control the air conditioner temperature, and when in the AUTOMATIC mode, it will control the fan speed to provide the necessary cooling at the quietest fan speed.

The system also monitors the current being drawn by all the electrical appliances in the motor home. Since the air conditioners draw a large amount of current, the climate control system may turn them off to prevent circuit overload. Once the system turns them off, it will keep them off as long as required, and then automatically return them to normal operation.

The system is designed to operate from 120-volt, 30-amp AC service **ONLY**. Connection of the motor home to any other power source will cause *improper* operation of the system. If only 20-amp service is available, current load management must be done manually by the owner and only one air conditioner can be operated at any one time.

---

Because of the many model, floor plans and option variations available, it is beyond the scope of this manual to include wiring diagrams. In certain situations, specific wiring diagrams may be available to help troubleshoot a problem. If you need specific wiring information, please contact your dealer. Complete wiring diagrams are not available.

## **ELECTRONIC CLIMATE CONTROL SYSTEM**



### **NOTE**

*A troubleshooting guide and function manual that explains this system is included with your motor home **Owner's Information Package**.*

## **ELECTRICAL WIRING DIAGRAMS**

The 120-volt circuit breakers and 12-volt fuses are located on three separate panels. The purpose of these three panels is to provide electrical circuit breakers and fuses to interrupt current flow if a circuit is overloaded.

1. **120-volt House Electrical** — *This electrical panel is located in an overhead cabinet in the galley. This panel is very similar to a residential panel with resettable breakers.*
2. **Fleetwood Automotive 12-volt System** — *This panel is located on the right side under the hood. This electrical center contains battery disconnect systems, entry step and some other automotive circuitry.*
3. **12-volt Chassis Fuses** — *This electrical panel is located under the driver's side instrument panel.*

## MOTOR HOME FUSES AND CIRCUIT BREAKERS



### WARNING

Do not install 12-volt fuses or 120-volt breakers with amperage ratings greater than that specified on the device or label. Doing so constitutes a fire hazard.

**This page intentionally blank.**



---

# LP GAS SYSTEM

Liquefied petroleum (LP) gas is the fuel used to operate the range, oven, furnace and water heater in your motor home. It is also used to power some refrigerators. LP gas is safe if it is handled and stored carefully and properly. It allows you to have the conveniences of home wherever you travel.

The LP gas storage tank is mounted on the motor home chassis. The gas is stored in the tank as a liquid under pressure. A pressure regulator controls the flow of the gas to your appliances.

A typical LP gas tank installation is illustrated below. Although specific details of the system may differ in your motor home, the major components and their relationships will be similar to those shown.

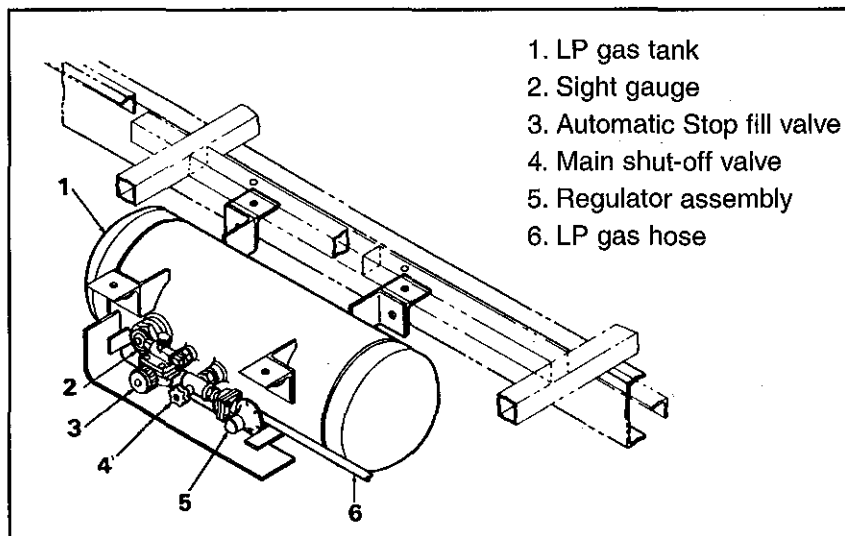

## **LP GAS SYSTEM**

---

As with any other volatile and flammable material, LP gas must be handled and used with caution. Because LP gas systems are so reliable, they are often taken for granted. Neglect can be a very dangerous habit. If the system is maintained regularly, you can expect almost trouble-free operation.

## **LP GAS SAFETY PRECAUTIONS**

### **WARNING**

LP gas is flammable and potentially explosive. Use proper handling, lighting and ventilating procedures.

1. The distinctive odor of LP gas indicates a leak. If you smell gas:

Do not touch electrical switches. Extinguish all open flames, pilot lights and all smoking materials. Shut off the gas supply at the container valve(s) or gas supply connection.

Open the door and leave the area until the odor clears.

Have the gas system checked by a professional and the cause of the leak corrected before using the motor home again.

2. Inspect the entire LP gas system for leaks or damaged parts before each trip and before filling the container. See section on "LP Gas System Leak Checks."

3. Never check for leaks with an open flame. Use an approved leak detection solution or a non-ammoniated, non-chlorinated soap solution only. If the leak cannot be located, take the unit to an LP gas service representative.

4. Always be careful when drilling holes or fastening objects to the motor home. The gas supply lines could be punctured by a nail or screw.



## WARNING

5. Do not restrict access to the LP containers. In an emergency, the tank service valve must be easily identified and accessible. The tank compartment door must always be unlocked, and the LP label should be visible.

6. Do not carry or store filled or empty LP gas containers, including accessories such as gas barbecues, in your motor home. LP gas containers are equipped with a safety device that relieves excessive pressure by discharging gas to the atmosphere. Leaks can occur at valves and fittings. Always store LP containers outside with the valves closed and plugged.

7. Do not use any LP gas container other than the one furnished with your motor home without being sure that all connecting components are compatible.

8. Turn off LP gas main valve before filling LP gas container or entering an LP gas bulk plant or motor fuel service station. Turn off all pilot lights and appliances individually before refueling of motor fuel tanks and/or LP gas containers.

When not individually turned off, automatic ignition appliances may continue to spark when LP gas is turned off at the container.

9. Do not fill LP gas containers to more than 80% capacity. Overfilling can result in uncontrolled gas flow which can cause fire and explosion, a properly filled container holds about 80% of its volume as liquid.

10. LP gas regulators must always be installed with the diaphragm vent facing downward. Make sure that the regulator vent faces downward and that the cover is kept in place to minimize vent leakage which could result in excessive gas pressure causing fire or explosion.

# LP Gas System

---



## WARNING

11. Do not use a wrench or pliers to close the tank shut-off valve. This valve is designed to be closed leak tight by hand. If a tool is required to stop a leak, the valve probably needs repair or replacement.
12. If you do not have the special tools and training necessary, do not attempt to repair or modify LP gas system components.
13. Always think safety.

---

The hoses used in your LP gas system meet *UL* or *CSA* requirements. Although they are designed for efficient and trouble free use, they can be damaged by sunlight and impurities in the air. The average life of LP hoses is two to three years. Check the hoses for signs of deterioration every time you have the gas tank filled or serviced. When you replace hoses, be sure that replacements are properly rated and approved for RV use.

## SYSTEM COMPONENTS

### *HOSES*

---

The regulator is the heart of the LP gas system. It reduces the high pressure of the gas in the tank down to the pressure that the appliances require. This pressure reduction occurs in two stages for safety and efficiency.

### *LP GAS REGULATOR*

The regulator is equipped with a vent. This vent must stay clean and open. The most common causes of regulator problems are clogging from corrosion, dirt, insect nests or other material. Even a small piece of material that finds its way into the vent can result in improper pressure in the system. This could damage the system or cause other parts of the system to fail.

The regulator is mounted so that the vent is facing downward and is protected from water and dirt by a water-resistant cover. Be sure the cover is on at all times. If the vent becomes clogged, it can be cleaned with a toothbrush. If you see corrosion, contact a qualified LP gas service technician for a replacement regulator.

**! WARNING**

Do not attempt to adjust the regulator. It has been preset by the regulator manufacturer. If any adjustment is required, it must be made by a qualified LP gas service technician using special equipment.

Your LP gas system will function at low temperatures, as long as the system components are kept at a temperature above the vapor point of the LP gas. Ask your LP gas supplier or your motor home dealer for information on LP gas blends available in your area and the areas in which you will be traveling.

## USING LP GAS SYSTEM AT LOW TEMPERATURES

The availability of gas is reduced at lower temperatures. Keep your LP tank as full as possible during cold weather. Check the BTU/hr. rating plates on your LP gas appliances. This information will help you manage your LP gas use. The chart below shows the reduction in available BTUs/hour at different fill levels as the temperature drops:

% FULL	20 lb. Tank*				
	+ 20°	0°	-5°	-10°	-15°
60%	36,000	18,000	12,750	8,500	4,250
50%	32,400	18,200	12,150	8,100	4,050
40%	28,800	14,400	11,400	7,600	3,800
30%	25,200	12,600	10,450	7,300	3,150
20%	21,600	10,800	8,100	5,400	2,700
10%	16,200	8,100	6,075	4,050	2,025

\*30 lb. Tank multiply x 1.40

## LP GAS SYSTEM

---

The chart clearly shows how the availability of the gas is reduced at lower temperatures. With this in mind, keep your LP tank as full as possible during cold weather. Check the BTU/hr. rating plates on your LP gas appliances. This information will help you manage your LP gas requirements efficiently.

LP gas systems can freeze up in very cold weather. Some people believe that the regulator or the gas itself freezes. Actually, the gas does not freeze. The moisture or water vapor that gets trapped in the system or absorbed by the gas freezes and causes the problem. This ice can build up and partially or totally block the gas supply.

### To prevent LP gas system freeze up:

1. Be sure the gas tank is totally moisture-free before it is filled. If you are not sure, have an LP service station inject an approved antifreeze or deicer into the tank.
2. Be sure the tank is not overfilled. This is also a safety consideration.
3. Have the gas tank purged by the LP gas service station if freeze up occurs.
4. Be sure you have the proper gas blend for your traveling area. If you have the proper gas blend, it is very unlikely that the gas is at fault. If, despite precaution, you do experience freeze up, ask your LP gas supplier to service the tank or regulator as required.

---

To fill the LP gas tank, drive the motor home to an LP gas supplier or a service station which sells LP gas. Do not attempt to fill the tank yourself.

 **WARNING**

Do not fill LP gas containers to more than 80% capacity. Overfilling can result in uncontrolled gas flow which can cause fire and explosion. A properly filled container holds about 80% of its volume as liquid.

 **WARNING**

Turn off LP gas main valve before filling LP gas tank or entering an LP gas bulk plant or motor fuel service station. Turn off all pilot lights and appliances individually before refueling of motor fuel tanks and/or LP gas containers. When not individually turned off, automatic ignition appliances may continue to spark when LP gas is turned off at the container.

## FILLING LP GAS TANK

The garlic-like smell of LP gas indicates a leak. Fittings, valves and couplings are the most common places for a gas system to leak.

For your safety, check for leaks in your gas system each time the tank is filled and before each trip. Always check the system any time you detect a garlic-like odor. Listen for a hiss or hum when you turn the gas on. This may indicate a leak.

The first time you have your LP tank filled, have the attendant bleed a little LP gas out of the small outage valve (this also lets you check that the tank is not overfilled) and note the odor. It should smell like garlic or onions. If you cannot detect this odor, you must take extra care in checking for leaks, as well as whenever you use LP gas appliances.

### To perform a leak check:

1. Swab a mixture of an approved leak detection solution over each fitting, joint and connection in the system.
2. Open the tank valve.
3. Inspect each joint.
4. If even the smallest bubbles appear at any joint, it is leaking and must be corrected. Take the motor home to an authorized Fleetwood service center or your LP gas service facility. Do not attempt to repair gas piping unless you have the proper tools and skill.

Leaks most likely will occur where piping runs close to the chassis and frame. Look for scrapes and cracks around pipe hangers. If you find defects in any part of the LP gas system, have it repaired or replaced before using the system.

Always check all exposed piping and fittings after you have arrived at a campsite and before you use any gas appliance. Travel and road shocks may have caused damage to the system that must be repaired before using the appliances.

Keep the tank valve closed and turn off all appliances if the motor home is not being used.

## LP GAS SYSTEM LEAK CHECKS

 **WARNING**

Never check for leaks with an open flame. Do not check for leaks using ammoniated or chlorinated household type detergents. These can cause cracks to form on the metal tubing and brass fittings. If the leak cannot be located, take the motor home to an LP gas service representative.

 **WARNING**

Do not use pliers or a wrench to tighten valves. If a valve is not leaktight when closed by hand, see an LP gas service representative.

## LP GAS SYSTEM

---

An LP gas leak detector is located near the floor in the galley area. The leak detector will sound a loud alarm if low levels of potentially dangerous LP gas are in the air.

The detector unit is powered by the 12-volt DC system in your motor home. A power switch is located on the panel. A green light on the detector front panel indicates that the detector has power.

Test the leak detector each time the motor home is relocated and set up for use.

### To test the LP gas leak detector:

1. Hold a butane-fueled pocket lighter near the sensor.
2. Open the lighter valve without striking the flame. The leak detector should respond within a few seconds.
3. Turn off, then reset the alarm.
4. Lightly fan the area around the detector to insure complete dispersion of the gas from the lighter, and to prevent another sounding of the alarm.
5. If the alarm does not sound during a test or if the green indicator light is not visible, see your dealer or an authorized Fleetwood Service Center. There are no batteries or use serviceable parts inside the unit.

## LP LEAK DETECTOR



### NOTE

*Remember to turn off the detector if you are not using your motor home. The detector draws enough current to discharge your battery.*



You will find detailed operating information for the LP gas appliances in your *Owner's Information Package*. Please read and follow these instructions.

### **LIGHTING LP GAS APPLIANCES**

Air trapped in the gas lines may delay the first lighting of any appliance. It could take several seconds or minutes for the gas to reach the appliance. To purge some of the air from the gas system, first light a burner on the range. The other appliances will then light more quickly.

We recommend lighting the pilot light at the range, if equipped, rather than individually lighting each burner. This will help prevent accidental leaks at the burner. Be sure to turn the pilot light OFF while traveling.

The first time the furnace or oven is operated, paints and oils used in its manufacture may generate some smoke and fumes. If this occurs, open doors and windows to air out the motor home. These materials should burn off after the first 15 to 20 minutes of appliance operation.

***Always follow the appliance manufacturer's lighting and operating instructions.***

**This page intentionally blank.**

---

# APPLIANCES

The appliances installed in your motor home are tested by independent laboratories and comply with rigid standards established by these organizations. All appliances are covered by Fleetwood's *Ownercare Warranty* program. Each appliance is also warranted by its manufacturer.



## NOTE

*The individual appliance manuals included in your **Owner's Information Package** contain detailed operating and maintenance instructions. Always refer to the respective manual for the appliance in question.*



## WARNING

The water heater and furnace combustion air exhaust ports may be extremely hot when the water heater and furnace are operating. Do not touch these outlets or allow any material to come near the exhaust ports while operating the water heater and/or furnace.

---

The water heater operates on LP gas, and is much like the one in your home. It contains an automatic shut off valve which stops the gas supply if the water temperature rises too high. The water heater is reached through an access panel on the outside of the motor home.

Turn on the hot water faucet at the galley sink. If water flows continuously the heater is full.

## WATER HEATER



## CAUTION

Do not light water heater until it is filled with water.

## Appliances

---

This valve is provided to cut off the flow of water to the water heater. The bypass valve greatly reduces the quantity of antifreeze required to winterize the water system.

To bypass the water heater, turn the lever valve vertical. To supply water heater with water, turn lever horizontal.

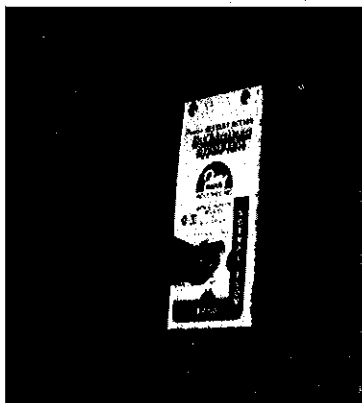

*Water Heater Bypass Valve*

## WATER HEATER BYPASS VALVE

---

Read the operating instructions furnished in your *Owner's Information Package*. Before operating the refrigerator when the motor home is parked, make sure it is level. If it is not level, the refrigerant will not circulate, cooling action will stop, and the refrigeration system may be damaged.

The refrigerator uses the absorption principle of operation. If you plan to cool food or drinks in high outside temperatures, precool the food, and park the motor home with the refrigerator vent door in the shade. Once the interior of the refrigerator is cool, the refrigeration system will usually maintain this temperature. If the inside of the refrigerator is hot, the food is not precooled, and the outside temperature is high, it will take longer for your food to be cooled.

## REFRIGERATOR

The furnace is a forced-air unit fueled by LP gas. All furnaces are equipped with a wall thermostat for individual temperature settings.

The furnace will not operate properly if your stored personal items block the free flow of air at the registers or the return air to the furnace. Storage under cabinets should be done carefully so as to not crush or damage the furnace ducting.

Smoke and fumes created as a result of burning off manufacturing compounds are sometimes present the first time the furnace is used. This is normal; however, when you light the furnace the first time, open all windows and doors until the residues are completely burned off. These materials should burn off after the first 15 to 20 minutes of appliance operation.

Always follow the appliance manufacturer's lighting and operating instructions.

If the furnace does not keep you comfortably warm, NEVER use the range, oven or a catalytic heater for supplementary heat – even with a vent or window open.

Combustion air for the furnace comes from outside the RV. The products of combustion in the furnace (carbon dioxide, carbon monoxide and other gases) are returned to the outside again for safe operation. Open flames in the RV will use up the oxygen in the vehicle. This oxygen is replaced with carbon monoxide.

When you use the range oven for cooking or baking, always open a vent or window to provide ventilation. Never operate the range or oven when you are sleeping or if your alertness is impaired in any way.

## FURNACE

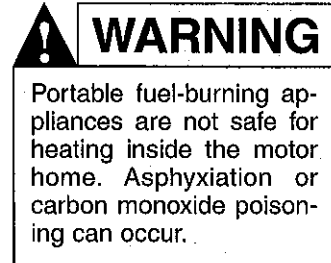

# Appliances

---

The gas oven and burners are operated with LP gas. The basic operation is the same as the range in your home.

A warning label has been located in the cooking area to remind you to provide an adequate supply of fresh air for combustion. Unlike homes, the amount of oxygen is limited in an RV due to the size and construction of the vehicle. Proper ventilation when using the cooking appliances will prevent the dangers of asphyxiation. Refer to **Lighting LP Gas Appliances** section in the **LP Gas System** chapter of this manual.

## RANGE

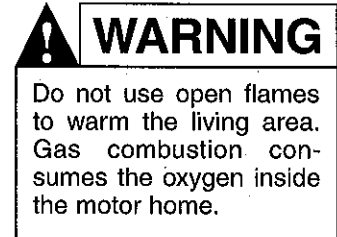

---

The exhaust hood allows vapors and cooking odors to escape, and provides a vent for the galley area. Switches for the fan and light are located on the front of the range hood. The hood has a grease filter screen which requires periodic cleaning. To clean, remove the screen and wash in soapy water. Rinse with water and let the screen drain dry.

## RANGE EXHAUST HOOD

Replace the light bulb with an equivalent type.

---

The roof-mounted air conditioners can operate only when the motor home is connected to 120-volt AC power from either a public utility or the generator. Be sure to turn the air conditioner circuit breaker ON.

## AIR CONDITIONER (IF EQUIPPED)

Each return air duct is equipped with a filter. Check these filters at regular intervals for accumulations of dust that could restrict air flow. To check the filters, remove the return air duct cover with a screwdriver.

For best performance, park the motor home in the shade and close curtains. Close doors and windows and turn the temperature control knob for desired coolness. Refer to the air conditioner manufacturer's instructions for detailed operating and preventive maintenance requirements. Remember that air conditioners use a large portion of your available electric power.

If the generator is running, either or both air conditioners can operate together. If the motor home is plugged into 30-amp service, both roof air conditioners can be operated at the same time with the assistance of the Climate Control System.

See the *Electrical System* chapter for operating details on the Fleetwood Climate Control System.



## NOTE

Your motor home is equipped with a ceiling-ducted air conditioning system. Each roof-mounted air conditioner is connected to its own duct system and is independent of the other air conditioner. For most efficient operation, adjust each vent so that it is completely open. If you change the vent opening to regulate air flow try not to restrict the vent opening to below 70% open. Restricting air flow below this opening will affect the efficiency of the air conditioner.

If additional equipment requiring 12-volt power is installed in the motor home, obtain the 12-volt source from a properly fused battery circuit. Consult an authorized Fleetwood dealer before adding any additional equipment to your motor home.

## ENTERTAINMENT EQUIPMENT

The 120-volt VCR can operate only when the motor home is connected to 120-volt power from either a public utility or the generator.

### 120-VOLT VCR (IF EQUIPPED)

The 120-volt/12-volt TVs can operate on a 12-volt power source (battery) as the motor home is delivered. Extended use of the TVs on 12-volt power can drain the batteries.

### 120/12-VOLT TELEVISION (IF EQUIPPED)

The TV can also operate on 120-volt power from the generator, public utility. Remove the 12-volt cord from the rear of the TV and install the 120-volt cord. Both 120- and 12-volt cords cannot be used at the same time. To use the TV on 120-volt power, the cords must be exchanged.

# Appliances

---

The video switcher, located near the VCR, allows routing of the antenna, cable or VCR signals to both the front and rear TVs independent of each other. You can also use the switcher to record or pass through the signals from the antenna or cable hookup.

## VIDEO SWITCHER

The roof-mounted antenna is designed for reception of VHF and UHF television signals.

## TV ANTENNA

Before traveling, remember to lower the antenna and secure it to prevent damage to the antenna, motor home roof, or objects in the path of the antenna, such as overhead wires. ***Do not travel with the antenna raised.***

✓	<b>NOTE</b>
<i>The antenna booster power supply must be turned off to prevent battery drain. A red indicator light will glow when the unit is on.</i>	

The roof-mounted satellite dish antenna is designed for reception of digital satellite television signals.

## SATELLITE DISH ANTENNA (IF EQUIPPED)

Before travelling, remember to lower the antenna and secure it to prevent damage to the antenna, motor home roof, or objects in the path of the antenna, such as overhead wires. Do not travel with the antenna raised.



The television and radio systems in your RV have been chosen to provide good performance under varied signal conditions. Occasionally, though, you may experience *ghosts* on TV, *flutter* when listening to FM broadcasts, or other signal interference.

The fault is normally not with your receiver or antenna system. The idea that antennas, whether amplified or not, “pull in” a signal is a popular misconception. An antenna does not pull a signal out of air by virtue of its “power.” The antenna only responds to signals present at the antenna elements. Antennas with boosters only amplify these signals.

Since distance from the broadcast tower is critical to reception clarity, remember that TV and FM signals have a range of only about 75 miles under the best of atmospheric and geographic conditions. The good reception you get at parks located at great distances from broadcast facilities is probably the result of satellite, microwave or other cable distribution systems. The antenna on your RV is no competition for these very expensive installations.

In addition, TV and radio frequency interference results from the electromagnetic fields produced by electric arc discharge. This arcing is found in lightning, vehicle ignition systems, and in 12-volt DC (brush type) motors used in power vents and furnaces. Nearly every DC motor has brushes. Most alternating current (AC) motors do not have brushes, and therefore do not generate the arcing interference. This is why this type of interference is less noticeable in a household environment.

As the signal diminishes with distance and geographical features (mountains, etc.), the effect of electric arc interference may become more and more noticeable. Eventually, the signal will be overcome by the interference. The following suggestions can improve reception:

## TV AND RADIO INTERFERENCE

	<b>CAUTION</b>
Lightning strikes during thunderstorms may affect the electrical systems in your motor home. Sensitive electronic equipment may be damaged by the electrical spikes and surges caused by electrical disturbances in the atmosphere. Disconnect the electrical power cord and cable TV service if you expect atmospheric electrical disturbances.	

# Appliances

---

- » Use the “park cable” TV antenna system of your RV in remote areas rather than the roof antenna if the campground provides cable hookup.
- » Turn the television antenna. Sometimes turning the antenna will pick up a stronger signal. Try turning or rotating the antenna throughout its range. You may find your signal in a very unexpected direction.
- » With FM stereo signals, switch the unit to MONO, if possible. Some of the phase and noise components of a stereo signal will disappear in MONO mode. Many FM stereo tuners are equipped with a “program adaptive blend” circuit. This circuit senses the condition of the RF signal. If the signal is too weak or contaminated with multipath reflections to be received in stereo without objectionable noise or distortion, the radio will automatically blend its stereo decoder toward mono. The radio will constantly vary its reception from full stereo to mono depending on the reception conditions. This variation and blending is built into the radio’s circuitry and happens automatically without requiring intervention by the listener.
- » Reduce the treble setting to reduce background noise. Although not yielding the best high-frequency performance, at least you may be able to reduce the irritation of the distortion and noise.

---

You may have additional appliances in your unit which operate only when connected to 120-volt power from either a public utility or the generator.

In some cases, appliance selector switches are provided in the galley to allow you to select combinations of appliances yet still remain within the power capacity of the electrical system.

## MISCELLANEOUS APPLIANCES

---

# MAINTENANCE

Your motor home has been designed to provide you with many years of use with a minimum amount of maintenance. This section will familiarize you with the areas of your motor home that require scheduled care. Time spent taking care of your motor home on a regular basis will pay for itself in extended service and will protect your investment.

If you are mechanically inclined and regularly perform routine maintenance and repairs on your car or truck, you may want to do the mechanical work on your motor home yourself. If you prefer, your dealer can perform these services for you. His trained personnel will assure that your motor home is maintained and repaired in keeping with original performance expectations.

This section is intended to provide the owner and operator with a general overview of service and maintenance information for the motor home. Detailed service and maintenance information may be found in the owner's/operator's manuals contained in the *Owner's Information Package*.

While the information in this section is intended to establish proper maintenance and inspection procedures, there may be times when detailed diagnostic and repair procedures may be required. Consult your dealer or an authorized Fleetwood Service Center in these situations.

---

Some exterior parts of your motor home are made of fiberglass. The finish on these parts is durable, but not indestructible. Any material and finish will deteriorate in time.

Exposure to sunlight, moisture and airborne pollutants can cause dulling and fading of the finish. Generally, changes in the finish due to weathering are cosmetic – they are on the surface of the part and do not affect its strength. Weathering can take the form of chalking, fading and yellowing.

## EXTERIOR

## **MAINTENANCE**

---

The best insurance against these effects is routine maintenance. If the finish is not washed and waxed thoroughly, the surface can deteriorate very rapidly. The following maintenance guidelines can help you reduce these weathering effects:

1. When the motor home is not in use, keep the fiberglass surfaces out of the sun or covered with a canvas tarpaulin. Avoid using plastic or other nonporous materials which can trap moisture between the cover and the fiberglass surface.
2. Wash the exterior with a mild soap monthly, at least. Avoid strong alkaline cleaners and abrasives. For the best results, use a cleaner formulated for fiberglass, and follow the directions for using the cleaner. **DO NOT use automatic dishwasher detergent, abrasives, bleaches, strong chemicals with acids/bases, or ammonia.**
3. Wax the exterior at least once a year — twice, if possible — with a wax formulated for fiberglass. When waxing, always read and follow the instructions and precautions on the container. Some cleaners and waxes are recommended for use on only certain types of surfaces.
4. In some cases, a light rubbing compound may be required. Always follow rubbing compound with a high-quality wax. Always follow the rubbing compound manufacturer's instructions.

---

Stains are generally caused by two types of substances — water soluble and non-water soluble. Water soluble stains can usually be washed away with water and mild detergent. Follow the washing with wax.

Non-water soluble stains are usually oil-based. Removal of this type of stain may require the use of highly flammable or poisonous solvents. Refer this type of service to your dealer or an authorized Fleetwood Service Center. Never use strong solvents or abrasives to clean plastic surfaces.

## **STAINS**

Keep moving parts, hinges and latches adjusted and maintained. Lubricate with a light oil at least once a year. Check and tighten the screws holding the windows in place as required. Clean screens by gently wiping with a damp cloth or soft flat brush. Not all screens are removable.

Inspect the sealants around doors and windows every three months. See *Sealant Renewal* section.

Lubricate locksets in doors and exterior storage compartments at least annually with powdered graphite. If the motor home is located at a beach or is exposed to salt air, more frequent lubrication may be required.

---

For normal cleaning, standard household detergents or cleansers may be used. Use a nonabrasive, common household detergent and plenty of water. Be sure to keep the sidewalls wet to reduce streaking. Road tar, tree sap or other stubborn stains can be removed with a soft rag and xylene.

### WINDOWS, DOORS, VENTS AND LOCKS

### RUBBER ROOF SYSTEM

#### CLEANING



#### WARNING

Xylene is a flammable liquid. Use extreme care when handling and using. Do not expose to open flame, spark or smoking material. Do not use in unventilated area.

## **MAINTENANCE**

---

The rubber roof itself does not require annual coatings or additional sealants. Periodic washing with soap and water is all that is required.

The rubber roof material can be cut by sharp objects. Use caution when loading sharp articles on the roof. If you add accessories or new equipment on the roof, be sure the installer is qualified to work on the rubber roof material. This is required under the terms of the warranty.

Repair kits are available through your dealer. The roof requires special adhesives and material.

## **CARE**

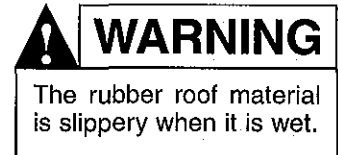

---

The adhesives and sealants used in the construction of your motor home were developed to remain waterproof under sustained effects of weather and vibration. However, even the finest materials will eventually dry out and lose their effectiveness under the constant heat of the sun and attack by other elements. This section outlines the procedures you must follow to maintain the weatherproof integrity of your motor home.

Your dealer can perform the resealing inspection and work for you. Your dealer also has current information on sealants used in your motor home, and can recommend the appropriate sealants for you if you prefer to do this work yourself. Always use the recommended sealants.

## **SEALANT RENEWAL**

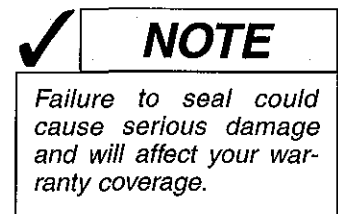

**Inspect the sealants around windows and doors at least every three months.** Also inspect roof vents, other roof components, moldings at front and rear caps, and perimeter molding. If any of the following defects are evident during inspection, the affected areas must be resealed.

- » Excessive amount of sealant protruding from joints.
- » Sealant cracked or peeling.
- » Voids in sealant.

**If you find any of the above defects:**

1. Use a plastic scraper to remove any excess sealant, any cracked or peeled sealant, or any voids in the sealant.
2. Clean all areas to be resealed with mineral spirits and clean rags.
3. Make sure that all areas to be resealed are absolutely dry before new sealant is applied.

## DOOR, WINDOW, ROOF COMPONENT AND MOLDING RESEALING



### NOTE

*Do not seal the bottom flanges of windows and doors. Special gaps in the sealant have been intentionally left in the bottom flange to provide exterior drainage in the event of leakage.*



### WARNING

Mineral spirits is a flammable liquid. Use extreme care when handling and using. Do not expose to open flame, sparks, or smoking material. Do not use in unventilated areas.

# **MAINTENANCE**

---

Interior appointments such as draperies, bedspreads, mattress covers, upholstery and wall pads are manufactured from high quality materials and should be dry cleaned only. Frequent vacuuming will keep them free of dust and dirt. Minor spills should be cleaned up quickly to avoid staining. The affected area should be blotted, not rubbed, to prevent the stain from working deeper into the fabric.

## **INTERIOR**

### **FABRICS**



#### **WARNING**

Do not use lacquer thinner, nail polish remover, carbon tetrachloride, spot remover, gasoline, or naphtha for any cleaning purpose. These products may cause damage to the material being cleaned, and may be highly flammable or poisonous.

For cleaning laminate surfaces, use mild dishwashing liquid with warm water. Use a soft cloth for both washing and drying.

### **LAMINATE TOP CARE**

Do not use abrasive cleaners, steel wool, or gritty cleaners or damage will occur to the surface.

Clean the hand-rubbed oil finish with soap and water. Do not immerse the board in water, store the board above a sink containing water, or expose it to continuous sunlight.

### **CUTTING BLOCK**



## ***MAINTENANCE***

---

The paneling and the ceiling of your motor home may be any of several finishes and textures. Never use harsh detergents or abrasive cleaners on walls or ceilings. Most surfaces will clean with a soft cloth moistened with mild liquid detergent in warm water, or a clear window cleaner solution. Do not scrub the surface or use large amounts of water which could saturate the material. Simply spray or apply the solution to the spot and blot with a clean dry rag or paper towel. Aggressive scrubbing may damage the texture or pattern.

### ***WALLS AND CEILING PANELS***

Some cleaners attack the plastic causing it to discolor and become brittle. The following cleaners have been tested and approved when mixed with water:

- » Distilled vinegar
- » Mild dishwasher detergent
- » Liquid deodorizing cleaner.

Avoid cleaners that contain any amount of abrasives, acetone or MEK (methyl ethyl ketone).

### ***BATHTUB AND PLASTIC SHOWER STALL***

Vinyl flooring requires only washing and periodic waxing. Vacuum carpeting regularly, and clean it with a quality carpet cleaner.

### ***FLOORS AND CARPETING***

The top of the engine may be accessed from inside the motor home for service by lifting or removing the engine cover.

### ***ENGINE ACCESS***



#### **WARNING**

When installing the engine cover, be sure the cover is fully seated on the gasket seal and secured by the clamps. Do not allow insulation, carpeting, or other material to interrupt the seal between the cover and the engine compartment. If the engine cover is not installed correctly, engine exhaust gases could leak into the passenger compartment creating a safety hazard. If the engine must be run with the engine cover off for maintenance purposes, be sure the vehicle interior is adequately ventilated.

## MAINTENANCE

For your convenience, a maintenance checklist is included in this manual. Options and accessories usually have their own owner/user manuals that often contain added maintenance instructions. Consult these manuals as required.

**Trailer Hitch Electrical Connector**  
(View is looking into the connector on the motor home)

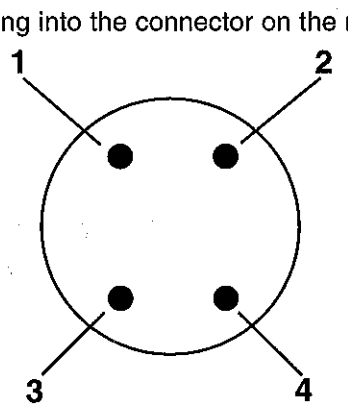

Terminal No.	Wire Color	Circuit Connection
1	Yellow	Lt. Turn & Stop
2	Green	Rt. Turn & Stop
3	White	Ground
4	Brown	License Tail/Clearance

## MAINTENANCE CHECKLIST

### TRAILER HITCH CONNECTOR WIRING

Windshield .....3M #SG-4799 black  
Window sealant .....Dow Corning 999 clear  
Color Metric 42120 clear  
Schnee-Moorehead 5732 clear  
Roof sealant .....Schnee-Moorehead #5504 or LaSalle-Deitch #MS-102

### EXTERIOR SEALANTS

Oil Filter.....185-2123 (Onan)  
Fuel Pump Filter .....149-1445 (Onan)  
Element Fuel Filter .....149-2106 (Onan)

### GENERATOR FILTERS

Detailed service and maintenance information for the Tag Axle System and its components can be found in the *Operation, Maintenance and Service Manual* included in the *Owner's Information Package*.

### TAG AXLE SYSTEM

**Interior - 12-volt**

Floor light.....	GE 53, 12-volt
Wardrobe light.....	GE 561, 12-volt
Ceiling 12" fluorescent.....	GE F-15T8-CW, 12-volt
Ceiling single incandescent.....	GE 1141, 12-volt
Ceiling double incandescent.....	GE 1141, 12-volt
Dinette decor light.....	1141 F, 12-volt
Bedroom decor lights.....	GE 1076, 12-volt
Range hood.....	GE 912, 12-volt
Driver/passenger courtesy light.....	GE 53, 12-volt
Bathroom vanity lamp.....	13W, 12-volt
Living area decor light.....	GE 1076, 12-volt

**Exterior**

Headlight, halogen high-low beam.....	GE 9007 XL, 12-volt
Front turn signal lights.....	Sylvania 3157 NA, 12-volt
Front clearance lights.....	Truck-Lite #30, 12-volt
Side marker lights.....	GE 193, 12-volt
Porch lights.....	Jensen 1003, 12-volt
Entry step light.....	GE 193, 12-volt
Rear clearance lights.....	GE 194, 12-volt
Back-up lights.....	GE 2057, 12-volt
Stop/tail lights.....	GE 1157, 12-volt
License plate light.....	GE 67, 12-volt
Rear turn signal lights.....	GE 2057, 12-volt

**LAMPS AND BULBS**

**CAUTION**

Before relamping, disconnect power source by removing fuse or placing circuit breaker and control switch in OFF position.

Halogen bulbs operate at extremely high temperatures and pressures and will shatter if not handled correctly.

Always use a soft dry cloth or cotton gloves when handling halogen bulbs.

Do not touch glass area with bare hands.

If bulb is touched with bare hands, wipe the bulb clean with rubbing alcohol.

Do not use near flammable or combustible materials and/or objects which may be sensitive to fading or drying.

Use bulbs designed or specific by manufacturer as to style, wattage and voltage.

**120-Volt, 30-Amp Service**

<b>Main 1</b>	1	Air conditioner.....	20A
	2	Portable appliance.....	20A
	3	General purpose.....	15A
	4	Microwave.....	20A
	5	Electronic Climate Control.....	15A

**FUSES AND  
CIRCUIT  
BREAKERS**

# MAINTENANCE CHART

	A	B	C	D	E	F	G	H	I
Wash exterior		●							
Wax exterior						●			
Lubricate and adjust exterior locks, hinges and window mechanisms						●			
Lubricate power step mechanism	●	●					●		
Lubricate TV antenna	●				●		●		
Check all exterior sealants, around windows, doors, sidewall seams, windshield, lamps, all exterior openings and roof components. Re-seal if necessary.	●			●			●		
Inspect and clean fuel-fired appliance vents: Water heater, refrigerator, furnace.	●		●			●	●		
Inspect and test safety equipment: Fire extinguisher, LP, CO and smoke detectors/alarms, and GFI receptacles.	●		●						
Service appliances and equipment: refrigerator, roof air conditioner, furnace, generator	●							●	
Inspect generator exhaust system		●							
Inspect LPG system including leak check	●	●					●		
Sanitize fresh water tank	●			●					
Clean drapes and interior fabrics	●				●				
Check exterior lamp operation	●	●							
Chassis service									●
Re-torque U-bolts (Mor-Ryde equipped only)									●

A - Start of Season

B - Each Trip or Monthly

C - Weekly

D - Every 3 Months

E - Each Year

F - Every 6 Month

G - End of Season

H - At Specified Mileage or Interval

I - At Specified Mileage for Heavy Duty Service

---

# STORAGE

## STORAGE CHECKLISTS

The following checklists will help you perform the steps necessary to prepare your motor home for storage. Use the checklist that applies to the storage conditions you anticipate. These checklists do not include every detail required, and you may want to expand them to suit your needs. Contact your dealer for additional suggestions suitable to your climate and storage conditions, particularly extremes of hot and cold.

- 
- Wash the motor home exterior and underside. Hose off accumulations of mud and road salts.
  - Thoroughly clean the interior of the motor home, including carpets, counter tops, lavy, tub and shower, and galley.
  - Inflate tires to maximum rated cold pressure.
  - Park the motor home as level as possible front to rear and side to side. Block wheels front and rear, put transmission in Park and set the parking brake.
  - Check the charge in the battery. Recharge as necessary.
  - Remove battery cables. Refer to the *Chassis Operator's/Owner's Guide/Manual* for proper removal and installation sequence. Clean terminals, top and sides of batteries and battery boxes. Reinstall cables, dress with a plastic battery terminal spray. Use battery disconnect switch/es, if equipped.
  - Drain holding tanks, toilet, and fresh water tank.
  - Winterize if appropriate. (See *Winterization* section in this manual.)

### SHORT-TERM STORAGE (LESS THAN 60 DAYS)

## **STORAGE**

---

- Turn off water pump and water heater master switches.
- Turn off LP gas at tank valve.
- Turn off refrigerator and furnace.
- Turn off all range and oven burner valves and pilot valves (if equipped).
- Remove all perishables from refrigerator and galley cabinets.
- Block refrigerator open to reduce odor buildup. An open box or tray of baking soda in the refrigerator will help absorb odors.
- Open closet doors, drawers, and cabinets so air can circulate.
- In warm or hot climates, slightly open ( $\frac{1}{4}$ " ) roof vents, at front and rear for ventilation. If the motor home is being stored below freezing, close and cover all vents to prevent entry of snow, etc.
- Close and lock all windows. Be sure vent fan and range hood fan switches are off.
- Cover exterior appliance vents (water heater, furnace, range hood, refrigerator) to prevent insects from getting in. Be sure to remove all covering material before using appliances or vents.
- Cap or close holding tank drain, city water inlet and fresh water fill spout.
- Turn off all radios, TVs, interior and exterior lights.
- Close curtains and/or mini-blinds, and pull shades.
- Disconnect the 120-volt power cord (shore cord), and store in compartment.

## STORAGE

---

- Cover tires with cloth, plywood, or aftermarket tire covers.
- Prepare generator (if equipped). Refer to generator operating manual included in your *Owner's Information Package*.
- Run the engine for about 15 minutes every 30 days. Turn the vehicle air conditioner ON during this run. Check engine oil, transmission fluid and coolant levels.

- 
- Perform all steps as required for short-term storage.
  - Run engine to normal operating temperature. Operate air conditioner to lubricate compressor seals. Drain engine oil, replace filter, refill engine with fresh oil.
  - Remove windshield wiper blades and store inside the motor home.
  - Charge and remove both the vehicle and auxiliary batteries. Store them in a cool, dry place, and check the charge and water level every 30 days. If the specific gravity is being checked, recharge the battery when it drops to 1.220. The time it takes the battery to reach 1.220 depends on its condition and the temperature. The colder the storage area, the slower the battery will self-discharge. A normal time between charges is three months.
  - Remove, clean and replace air conditioner filters. Cover the air conditioner shroud(s).
  - Winterize if appropriate. (See *Winterization* section in this manual.)

### LONG-TERM STORAGE (OVER 60 DAYS)



#### NOTE

If your motor home is equipped with a solar battery charger it will trickle charge both house and automotive batteries. The battery disconnect switch must be ON for the solar charger to charge the batteries.

## STORAGE

---

- Cover the windows on the inside with foil, cardboard, paper, etc., to reduce curtain, drape, and carpet fading.
- Cover the external refrigerator, water heater and furnace vents. This will prevent mice, insects, and some spiders that are attracted to LP gas from building nests that can disrupt the air flow and keep appliances from functioning properly.
- Remove batteries in clocks or other battery-powered devices.
- During extended periods of storage, fuel may deteriorate due to oxidation. This can damage rubber and other materials in the fuel system. It may also clog small orifices. Commercially available fuel stabilizers may be added whenever actual or expected storage periods exceed 60 days. Follow the additive manufacturer's instructions. Operate the vehicle regularly during the storage period to mix and circulate the anti-oxidant agent throughout the fuel system.
- Refer to the *Chassis Operator's/Owner's Guide/Manual* for procedures on extended vehicle storage.
- Check tire inflation pressures every 30 days. Maintain maximum rated cold inflation pressure.
- Check the sealant around all roof and body seams and windows. Reseal if necessary. See *Sealant Renewal* section.
- Lubricate all locks and hinges as described in the *Maintenance* chapter.
- Remove high grass or weed growth.



Thoughtful planning and preparation for the winter season can help eliminate equipment failures and breakdowns, and can extend the life of your motor home and its systems. Your dealer can advise you concerning specific winterization procedures and products for your climate area or the areas through which you will be traveling. Your dealer may also provide winterization service for all appliances and systems in the motor home. The following is a check list if you prefer to perform these procedures yourself:

## WINTERIZATION

- Check engine coolant level and antifreeze protection. Drain and flush engine cooling system and add antifreeze to protect the system to the lowest expected storage temperature or at least -20 F.
- Service and winterize the generator (if equipped) as outlined in the generator operating manual included in your *Owner's Information Package*.
- Winterize the LP gas system. Your LP dealer or service station will perform this for you.
- Winterize all appliances as outlined in the individual operator's manuals.
- Remove snow accumulations as often as possible.

- 
- Read this section completely before performing winterization.
  - Remove water purifier filter cartridge, if equipped, and install the winterizing plug.
  - Drain the fresh water tank by opening the water tank drain valve located inside the chassis compartment. Leave the valve open.

## WATER SYSTEM WINTERIZING

## STORAGE

---

- Turn water pump on (12-volt power must be on). Open a cold water faucet. When the flow of water stops, turn the pump off.
- Open water faucets. Then open the drain valves on HOT and COLD water pipes. Leave those valves open.
- Drain the water heater by opening the drain plug at the bottom of the heater and the safety valve at the top.
- Flush the toilet. Operate toilet sprayer, if equipped.
- Drain the showerhead by opening the valve. Let all water drain out the tub spout. Leave the valve open.
- When each faucet has been drained, close all faucets, water line drain valves and the fresh water tank drain valve. Install the water heater plug and close the safety valve.
- Drain the waste water system by following the normal procedure for draining the holding tanks. (See *Plumbing* chapter).
- Apply silicone lubricant to the knife valve actuator rod(s).
- Be sure ALL water from ALL plumbing fixtures has been drained.
- Open low point drains. (See *Plumbing* chapter).
- Close holding tank drain valves, low point drain valves and fresh water tank drain valve.
- Pour approximately five gallons of approved non-toxic antifreeze into the fresh water tank.

 **CAUTION**

Draining the water system alone will not provide adequate cold weather protection. If the motor home is to be unheated during freezing temperatures, consult your dealer for the best winterizing procedure for your climate. Your dealer can winterize your motor home for you or can supply you with one of the special antifreezes which are safe and approved for use in RV water systems. Follow the instructions furnished with the antifreeze.

 **WARNING**

Do not use automotive or windshield washer antifreeze in the motor home water system. These solutions may be harmful if swallowed.

- Turn the water pump master switch ON.
- Open each cold water faucet, run the water pump and let about a cup of antifreeze solution flow continuously through each faucet. Close each cold water faucet.
- Flush the toilet until the antifreeze solution flows continuously. Release flush mechanism.
- Winterize the water heater according to the instructions provided with the water heater operating manual. Winterize the hot water lines by opening each hot water faucet, allowing antifreeze solution to flow continuously, and then close each faucet. This will require considerably more antifreeze solution, and you may choose to do this step before winterizing the cold water lines so you can recycle the solution.
- When filling the plumbing systems with antifreeze, be sure to open and operate all fixtures and valves allowing the antifreeze solution to flow freely.
- Pour one cup of antifreeze solution down each drain.
- Install all protective caps:
  - Water tank fill
  - City water Inlet cap
  - Waste tank drain outlet cap



### NOTE

A bypass valve (see **Plumbing** chapter) allows the user to bypass the water heater - allowing it to be drained - to reduce the amount of antifreeze required to winterize the fresh water system.

## **STORAGE**

---



If your refrigerator is equipped with an ice maker, winterize it as follows:

1. Shut off the water supply valve to the ice maker.
2. Place a shallow pan under the water solenoid valve.
3. Remove the inlet fitting to the ice maker water solenoid valve. Drain the water from the supply line.
4. Remove the plastic nut and water line from the outlet side of the water solenoid valve. Drain water from the line.
5. Cycle the ice maker several times while blowing compressed air through the water solenoid valve. Be sure all water is out of the solenoid. **NOTE: Your motor home dealer can do this for you.**
6. Reconnect and tighten the lines on the solenoid valve. Leave the water supply turned off until temperatures are above 32 degrees F./0 degrees C.
7. Dry out the ice maker mold assembly with a soft cloth. Place the bail arm to the **UP/OFF** position.

If the motor home was properly and carefully prepared for storage, taking it out of storage will not be difficult. The following procedure check list assumes that you stored the motor home with care. If you didn't, and extensive freeze damage or other serious deterioration has occurred, please consult your dealer or an authorized Fleetwood Service Center for advice.

## REACTIVATING THE MOTOR HOME AFTER STORAGE

- Thoroughly inspect the outside of the vehicle. Look for animal nests in wheelwells, under the hood, in air cleaner or in other out of the way places.
- Remove all appliance vent, ceiling vent and air conditioner coverings. Be sure all furnace, water heater, and refrigerator openings are clear and free of debris or insect nests, webs, etc.
- Open all doors and compartments. Check for animal or insect intrusion, water damage, or other deterioration.
- Refer to the *Chassis Operator's/Owner's Guide/Manual* for procedures on reactivating the vehicle after storage.
- Check all chassis fluid levels — engine oil, engine coolant, power steering fluid, brake fluid, transmission fluid, rear axle oil.
- Check charge level in batteries. Refill and recharge as necessary. Reinstall batteries if necessary. Be sure cable ends and terminals are clean and free of corrosion.
- Check tire pressures. Reinflate to specified cold pressure.
- Remove covering from inside windows.
- Open vents and windows for ventilation.

## STORAGE

---

- Be sure engine instruments indicate proper readings. Run engine up to operating temperature. Shut engine down. Check all fluids. Top off if necessary.
- During engine run, check the operation of headlights, tail-lights, turn signals, backup lights, clearance lights, license plate light, emergency flashers. Check the exhaust system for leaks or deterioration. Operate the vehicle air conditioner. If air conditioner does not work, or unusual sounds occur, have the system checked by a qualified air conditioner technician.
- Drain, flush, and sanitize the fresh water system as outlined in the **Plumbing** chapter. Inspect the drain hose for leaks. Replace if necessary — repairs are usually not effective.
- Install a new water filter cartridge (if equipped).
- Operate all faucets and fixtures in the fresh water system. Check for leaks at all joints and fittings. Repair if necessary.
- Check 12-volt circuit breakers and inspect fuses.
- Operate all 12-volt lights and accessories.
- Install new batteries in battery-operated devices. Check operator's manual for each device for additional requirements.
- Test carbon monoxide, LP gas and smoke detectors/alarm.
- Check monitor panel operation.

- Open and operate vents and vent fans, including the range hood fan.
- Inspect the 120-volt electrical system — power cord, converter, inverter, all outlets, and any exposed wiring. If defects are found, refer service to your dealer or an authorized Fleetwood Service Center.
- Prepare the generator for operation following instructions in the generator operating manual in your *Owner's Information Package*.
- Start and run generator. Check the generator exhaust system for leaks or deterioration.
- Operate 120-volt appliances and air conditioners. Be sure to uncover air conditioner shroud(s).
- Inspect the LP gas system and check for leaks as described in the *LP Gas System* chapter. If the LP tank shows signs of rust or corrosion, have it inspected by a qualified LPG technician.
- Operate each LP gas appliance. Observe all burner/pilot flames for proper color and size. In any case, have the LP gas regulator adjusted for proper pressure by a qualified technician.
- Inspect and clean the interior.
- Check the sealant around all roof and body seams and windows. Reseal if necessary. See *Sealant Renewal* section.
- Lubricate all exterior locks, hinges, and latches.
- Reinstall windshield wiper blades or remove protective covers. Check wiper/washer operation.

## **STORAGE**

---

- Wash and wax the exterior. Inspect the body for scratches or other damage. Touch up or repair as necessary. Flush the underside thoroughly.
- Run thorough operational checks of steering, brakes, engine and transmission. Operate vehicle slowly during these checks to allow sufficient circulation of fluids and reseating of components.

Your motor home should now be ready for a new traveling season. If you choose, your dealer can double check your preparation and correct any defects or make any necessary adjustments.



---

# GLOSSARY

**AC INVERTER** - An electronic device that changes 12-volt DC energy from the batteries to 120-volt 60-cycle, AC energy to operate microwave ovens, TVs, VCRs, or other appliances that require 120-volt 60-cycle power.

**BELTED SEATING POSITIONS** - These are seats with seat belts. Anyone riding in the motor home must use one of these seats any time the motor home is in motion.

**BLACK WATER TANK** - The water tank in your plumbing system that is designed to contain waste water from the toilet ONLY.

**CAUTION** - Any statement in this *Owner's Manual* that, if not followed, could result in damage to the vehicle or components.

**CHASSIS OPERATOR'S/OWNER'S GUIDE/MANUAL** - This is the operating and maintenance manual supplied by the chassis manufacturer. It is part of your *Owner's Information Package*. It contains information on operating and maintaining the engine, transmission, drivetrain and other components of the motor home chassis.

**DC CONVERTER** - An electronic device that changes 120-volt AC energy from the main power connection or the generator to 12-volt DC energy to operate the 12-volt interior lights or other 12-volt DC appliances or accessories.

**DESIGNATED SEATING CAPACITY (CANADIAN UNITS ONLY)** - The number of sleeping positions designated equals the seating capacity.

**DOORSIDE** - The right side of the motor home from the driver's point of view. So named because the main entry/exit door is usually on this side.

**FIN (FLEETWOOD IDENTIFICATION NUMBER)** - This is the number that identifies your motor home as a Fleetwood product. Use this number when ordering parts or requesting warranty service for your motor home.

# Glossary

---

**GAWR (Gross Axle Weight Rating)** - The maximum permissible loaded weight a specific axle is designed to carry.

**GCWR (Gross Combined Weight Rating)** - The value specified by the motor home manufacturer as the maximum allowable loaded weight of this motor home with its towed trailer or towed vehicle. Towing and braking capacities may be different. Refer to Fleetwood and the chassis manufacturer's manuals for complete information.

**GEAR PRESELECTION** - The selection of a lower gear to match the driving conditions you encounter or expect to encounter. Preselection will give you better control on slick or icy roads and on downgrades. Downshifting to lower gears increases engine braking. The selection of a lower gear often prevents cycling between a gear and the next higher gear on a series of short up-and-down grades.

**GFCI (Ground Fault Circuit Interrupter)** - An electrical device attached to the bathroom AC circuits that disconnect the outlet if a problem occurs in the ground circuit.

**GRAY WATER TANK** - The water tank in your plumbing system that is designed to contain waste water from the sinks and shower drains ONLY. No toilet wastes go into this tank.

**GTW (Gross Towing Weight)** - The maximum permissible loaded weight of a trailer or car that this motor home has been designed to tow. This cannot be increased by changing the trailer hitch.

**GVWR (Gross Vehicle Weight Rating)** - The maximum permissible weight of this motor home. The GVWR is equal to or greater than the sum of the Unloaded Vehicle Weight plus the Net Carrying Capacity.

**ICC Switch** - Intermittent Courtesy Circuit. This switch will flash the clearance lights and is useful when signalling other large vehicles when passing or being passed.

**MONITOR PANEL** - An electronic device that allows you to conveniently measure the approximate levels in the fresh water, gray and black water tanks. You can also check the charge in the battery/batteries.

**NCC (NET CARRYING CAPACITY)** - The maximum weight of all occupants including the driver, personal belongings, food, fresh water, LP gas, tools, the tongue weight of towed vehicle, dealer installed accessories, *etc.*, that can be carried by this motor home. Normal variation of materials may cause the Net Carrying Capacity to be 200 lbs. higher or lower than stated. (NCC is equal to or less than GVWR minus UVW.)

**NOTE** - A statement or instruction in this *Owner's Manual* with information to help you use the vehicle or equipment more efficiently, such as a tip.

**OWNER'S INFORMATION PACKAGE** - This is a package of papers, manuals, warranty and instruction cards, and other material put together for you by Fleetwood. These materials contain operating and maintenance instructions for most of the components and appliances in your motor home.

**OWNERCARE CARD** - The card that has your name and vehicle ID (FIN) embossed on it. Use this card when you request or need warranty service. Please note that this is NOT a credit card. You cannot purchase anything with it. It is used only to identify you and your motor home.

**Park Cable** - The F-style video connector that allows you to connect to an outside television signal source, such as the cable TV feed at an RV park, or any other 75-ohm video source. This connector usually carries an RF modulated signal.

# Glossary

---

**Park/City WATER CONNECTION** - The "garden-hose" style connector that allows you to connect to an outside pressurized water source.

**POWER/ShORE Cord** - This is the main power cord coming into your motor home electrical system. You connect it to 120-volt AC power at a park or campsite.

**Predelivery Inspection** - This is the procedure required by Fleetwood that your dealer performs before you take delivery of the motor home at the time of sale.

**Roadside** - The left side of the motor home from the driver's point of view. So named because, at least in North America, the "road" outside the vehicle is usually on this side.

**TW (Tongue Weight)** - The maximum permissible downward force exerted on the hitch ball by the towed vehicle coupler.

**UVW (Unloaded Vehicle Weight)** - The weight of the motor home, as built at the factory with full fuel, engine oil and coolants. The UVW does not include cargo, fresh water, LP gas, occupants or dealer installed accessories. **Note: Canadian UVW includes designated seating, LP and water.**

**VIN (Vehicle Identification Number)** - The legal 17-digit vehicle identification number as shown on the vehicle registration certificate.

**WARNING** - A statement or instruction in this *Owner's Manual* that, if not followed, could lead to personal injury or death.