

**TIOGA<sup>®</sup>**  
**ARROW**  
*BY FLEETWOOD<sup>®</sup>*

**1990**



# FULL ONE-YEAR/15,000 MILE WARRANTY

FOR MOTOR HOMES MANUFACTURED BY SUBSIDIARIES OF FLEETWOOD ENTERPRISES, INC.  
SOLD IN THE UNITED STATES AND CANADA

## COVERAGE PROVIDED

Your new motor home, including the structure, plumbing, heating and electrical systems, and all appliances and equipment installed by the manufacturer, is warranted under normal use to be free from manufacturing defects in material or workmanship.

The warranty extends to the first retail purchaser and his transferee(s) and begins on the date of original retail delivery or the date the motor home is first placed into service as a rental, commercial or demonstrator unit (whichever occurs first). The warranty extends for a period of one year from such date or until the unit has received 15,000 total miles of use as determined by the mileage shown on the odometer (whichever occurs first). Written notice of defects must be given to the selling dealer or the manufacturer not later than ten (10) days after the expiration of the applicable warranty period.

## OWNER'S OBLIGATIONS

The owner is responsible for normal maintenance as described in the Owner's Manual; however, minor adjustments (such as adjustments to the interior of exterior doors, LP regulator pressure, cabinet latches, TV antenna control, etc.) will be performed by the dealer during the first 90 days of warranty coverage. Thereafter, such adjustments are the responsibility of the owner as normal maintenance unless required as a direct result of repair or replacement of a defective part under this warranty.

If a problem occurs which the owner believes is covered by this warranty, the owner shall contact the SELLING DEALER, or other authorized dealer, giving him sufficient information to resolve the matter. The owner shall deliver the motor home to the DEALER or manufacturing plant location for warranty service.

## DEALER'S OBLIGATIONS

By agreement with the manufacturer, the dealer is obligated to maintain the motor home prior to retail sale, to perform a detailed pre-delivery inspection and to repair or replace any parts necessary to correct defects in material or workmanship.

## WHEN THE DEALER DOES NOT RESOLVE THE PROBLEM

If the dealer is unable or unwilling to resolve a problem which the owner is convinced is covered by the warranty, he should contact the MANUFACTURING PLANT at the address listed below and provide the manufacturer with a description in writing of the problem and attempts made to resolve it.

## MANUFACTURING PLANT OBLIGATIONS

Upon receipt of notice of a claim, where the dealer was unable or unwilling to resolve the problem, the manufacturing plant will repair or replace any parts necessary to correct defects in material or workmanship, or will take other appropriate action as may be required.

## WHEN THE MANUFACTURING PLANT DOES NOT RESOLVE THE PROBLEM

If the representatives of the manufacturing plant are unable to resolve the problem and the owner is convinced that it is covered by the warranty, the owner should call the toll-free number listed below to describe the problem and the attempts made to resolve it.

## WHAT IS NOT COVERED BY THE EXPRESS WARRANTY

THIS WARRANTY DOES NOT COVER:

1. THE AUTOMOTIVE SYSTEM (INCLUDING THE CHASSIS AND DRIVE TRAIN), TIRES AND BATTERIES, WHICH ARE COVERED BY THE SEPARATE WARRANTIES OF THE RESPECTIVE MANUFACTURERS OF THESE COMPONENTS.
2. DEFECTS CAUSED BY OR RELATED TO:
  - A. ABUSE, MISUSE, NEGLIGENCE OR ACCIDENT;
  - B. FAILURE TO COMPLY WITH INSTRUCTIONS CONTAINED IN THE OWNER'S MANUAL
  - C. ALTERATION OR MODIFICATION OF THE MOTOR HOME;
3. NORMAL DETERIORATION DUE TO WEAR OR EXPOSURE, SUCH AS FADING OF FABRICS OR DRAPES, CARPET WEAR, ETC.
4. NORMAL MAINTENANCE AND SERVICE ITEMS, SUCH AS LIGHT BULBS, FUSES, WIPER BLADES, LUBRICANTS, ETC.
5. MOTOR HOMES ON WHICH THE ODOMETER READING HAS BEEN ALTERED.
6. TRANSPORTATION TO AND FROM DEALER OR MANUFACTURING PLANT LOCATION, LOSS OF TIME, INCONVENIENCE, COMMERCIAL LOSS, LOSS OF USE, TOWING CHARGES, BUS FARES, CAR RENTAL, INCIDENTAL CHARGES SUCH AS TELEPHONE CALLS OR HOTEL BILLS, OR OTHER INCIDENTAL OR CONSEQUENTIAL DAMAGES.

SOME STATES DO NOT ALLOW THE EXCLUSION OR LIMITATION OF INCIDENTAL OR CONSEQUENTIAL DAMAGES, SO THE ABOVE LIMITATION OR EXCLUSION MAY NOT APPLY TO YOU.

THIS WARRANTY GIVES YOU SPECIFIC LEGAL RIGHTS, AND YOU MAY ALSO HAVE OTHER RIGHTS WHICH VARY FROM STATE TO STATE.

THE MANUFACTURER IS NOT RESPONSIBLE FOR ANY UNDERTAKING, REPRESENTATION, OR WARRANTY MADE BY ANY DEALER OR OTHER PERSON BEYOND THOSE EXPRESSLY SET FORTH IN THIS WARRANTY.

Brand Name TIOGA ARROW Model \_\_\_\_\_ Serial No. \_\_\_\_\_

MANUFACTURING PLANT:

CORPORATE HEADQUARTERS:

Consumer Affairs Department  
Fleetwood Enterprises, Inc.  
P.O. Box 7300  
Riverside, California 92523  
From Calif.: (800) 442-4804  
From Outside of Calif.: (800) 854-4755

## SAFETY REGULATIONS REGARDING LP GAS SYSTEMS AND LP GAS APPLIANCES

The manufacturer of this recreational vehicle is required to furnish the following consumer information as provided by the National Fire Prevention Association and the American National Standards Institute. The information and warnings found here may also be found in other sections of this Owner's Manual. Please see sections titled "Liquid Petroleum Gas System" and "Appliances" for other safety and operating information.

**WARNING:** LP GAS CONTAINERS SHALL NOT BE PLACED OR STORED INSIDE THE VEHICLE. LP GAS CONTAINERS ARE EQUIPPED WITH SAFETY DEVICES WHICH RELIEVE EXCESSIVE PRESSURE BY DISCHARGING GAS TO THE ATMOSPHERE.

**WARNING:** IT IS NOT SAFE TO USE COOKING APPLIANCES FOR COMFORT HEATING. COOKING APPLIANCES NEED FRESH AIR FOR SAFE OPERATION. BEFORE OPERATION:

1. OPEN OVERHEAD VENT OR TURN ON EXHAUST FAN, AND
2. OPEN WINDOW.

THIS WARNING LABEL HAS BEEN LOCATED IN THE COOKING AREA TO REMIND YOU TO PROVIDE AN ADEQUATE SUPPLY OF FRESH AIR FOR COMBUSTION. UNLIKE HOMES, THE AMOUNT OF OXYGEN SUPPLY IS LIMITED DUE TO THE SIZE OF THE RECREATIONAL VEHICLE, AND PROPER VENTILATION WHEN USING THE COOKING APPLIANCES(S) WILL AVOID DANGERS OF ASPHYXIATION. IT IS ESPECIALLY IMPORTANT THAT COOKING APPLIANCES NOT BE USED FOR COMFORT HEATING AS THE DANGER OF ASPHYXIATION IS GREATER WHEN THE APPLIANCE IS USED FOR LONG PERIODS OF TIME.

**WARNING:** PORTABLE FUEL-BURNING EQUIPMENT, INCLUDING WOOD AND CHARCOAL GRILLS AND STOVES, SHALL NOT BE USED INSIDE THIS RECREATIONAL VEHICLE. THE USE OF THIS EQUIPMENT INSIDE THE RECREATIONAL VEHICLE MAY CAUSE FIRES OR ASPHYXIATION.

**WARNING:** DO NOT BRING OR STORE LP GAS CONTAINERS, GASOLINE, OR OTHER FLAMMABLE LIQUIDS INSIDE THE VEHICLE BECAUSE A FIRE OR EXPLOSION MAY RESULT.

A warning label has been located near the LP gas container. This label reads: DO NOT FILL CONTAINER(S) TO MORE THAN 80 PERCENT OF CAPACITY. Overfilling the LP gas container can result in uncontrolled gas flow which can cause fire or explosion. A properly filled container will contain approximately 80 percent of its volume as liquid LP gas.

The following label has been placed in the vehicle near the range area:  
IF YOU SMELL GAS:

1. Extinguish any open flames, pilot lights and all smoking materials.
2. Do not touch electrical switches.
3. Shut off the gas supply at the tank valve(s) or gas supply connection.
4. Open doors and other ventilating openings.
5. Leave the area until odor clears.
6. Have the gas system checked and leakage source corrected before using again.

LP gas regulators must always be installed with the diaphragm vent facing downward. Regulators that are not in compartments have been equipped with a protective cover. Make sure that regulator vent faces downward and the cover is kept in place to minimize vent blockage which could result in excessive gas pressure causing fire or explosion.

## IMPORTANT NOTICE

Certain of our forest product suppliers have advised that urea-formaldehyde is used in the production of particle board, hardwood plywood or paneling which they supply us and which we utilize in our finished product. These suppliers have requested that we communicate this to our customers.

For your information, we are reproducing samples of statements which have been provided to us by our suppliers.

**WARNING:** THIS PRODUCT IS MANUFACTURED WITH UREA-FORMALDEHYDE RESIN. FORMALDEHYDE VAPOR MAY IN SOME PEOPLE CAUSE HEADACHES, EYE, NOSE AND THROAT IRRITATION, AND AGGRAVATION OF ALLERGIES AND RESPIRATORY PROBLEMS, SUCH AS ASTHMA. PROPER VENTILATION SHOULD REDUCE THE RISK OF SUCH PROBLEMS.

*Champion International Corporation*

**WARNING: IRRITANT:** THIS PRODUCT CONTAINS A UREA-FORMALDEHYDE RESIN AND MAY RELEASE FORMALDEHYDE VAPORS IN LOW CONCENTRATIONS. FORMALDEHYDE CAN BE IRRITATING TO THE EYES AND UPPER RESPIRATORY SYSTEM OF ESPECIALLY SUSCEPTIBLE PERSONS SUCH AS THOSE WITH ALLERGIES OR RESPIRATORY AILMENTS. USE WITH ADEQUATE VENTILATION. IF SYMPTOMS DEVELOP, CONSULT YOUR PHYSICIAN.

*Georgia-Pacific Corporation*

**WARNING:** THIS PRODUCT IS MANUFACTURED WITH A UREA-FORMALDEHYDE RESIN AND WILL RELEASE SMALL QUANTITIES OF FORMALDEHYDE. FORMALDEHYDE LEVELS IN THE INDOOR AIR CAN CAUSE TEMPORARY EYE AND RESPIRATORY IRRITATION, AND MAY AGGRAVATE RESPIRATORY CONDITIONS OR ALLERGIES. VENTILATION WILL REDUCE INDOOR FORMALDEHYDE LEVELS.

*Weyerhaeuser Company*

Ventilation is important in maintaining a comfortable environment and we direct your attention to the discussion of ventilation contained in your Owner's Manual.

# TABLE OF CONTENTS

<b>INTRODUCTION</b> . . . . .	1	<b>Effects Of Prolonged Occupancy</b> . . . . .	19
<b>Planning And Preparation</b> . . . . .	2	<b>Controlling Moisture Condensation</b> . . . . .	19
<b>Loading And Weight Distribution</b> . . . . .	2	<b>Fire Safety</b> . . . . .	20
<b>Have It All Under Control</b> . . . . .	2	Smoke Detector . . . . .	20
<b>Inspect And Maintain</b> . . . . .	2	<b>PLUMBING SYSTEMS</b> . . . . .	21
<b>The Owner's Information Package</b> . . . . .	2	<b>Fresh Water System</b> . . . . .	21
<b>Chassis And Vehicle Identification</b> . . . . .	3	The Water Pump . . . . .	21
<b>Keys And Locks</b> . . . . .	3	The Monitor Panel . . . . .	22
<b>Other Sources of Information</b> . . . . .	3	Sanitizing The Fresh Water System . . . . .	22
<b>Emergency And Identification Information</b> . . . . .	4	Troubleshooting The Fresh Water System . . . . .	22
<b>Pre-Travel Check List</b> . . . . .	6	Leaks . . . . .	22
<b>COCKPIT AND DRIVER'S CONTROLS</b> . . . . .	7	Clogged Water Filter . . . . .	22
Cruise Control . . . . .	7	Excessive Water Pressure . . . . .	23
Auxiliary Start System . . . . .	7	Water Pump Troubleshooting . . . . .	23
Driver/Passenger Seats . . . . .	7	<b>The Waste Water System</b> . . . . .	23
Seat Belts . . . . .	7	Toilet . . . . .	24
Child Restraint . . . . .	7	Toilet Maintenance . . . . .	24
Side Slider Windows . . . . .	8	Toilet Troubleshooting . . . . .	24
<b>Driving And Parking</b> . . . . .	8	Dumping The Holding Tanks . . . . .	24
<b>Fuel And Fuel Systems</b> . . . . .	8	Holding Tank Care And Maintenance . . . . .	25
Fuel Fill . . . . .	8	<b>Water System Winterizing</b> . . . . .	26
Fuel Types And Vapor Lock . . . . .	8	<b>ELECTRICAL SYSTEMS</b> . . . . .	27
Alternative Fuel Types . . . . .	9	<b>Chassis Electrical System</b> . . . . .	27
Overheating . . . . .	9	Chassis Bulbs & Fuses . . . . .	27
<b>Engine Exhaust System Component Heat</b> . . . . .	9	<b>12-volt Coach System</b> . . . . .	27
<b>Carbon Monoxide Safety Precautions</b> . . . . .	9	Auxiliary Battery . . . . .	27
<b>Safety Tips</b> . . . . .	10	Battery Inspection and Care . . . . .	27
Engine Access . . . . .	10	Battery Charging . . . . .	27
<b>Tires</b> . . . . .	10	Selecting A Replacement Battery . . . . .	28
Tire Replacement . . . . .	10	<b>120-volt AC System</b> . . . . .	28
Changing A Flat Tire . . . . .	10	The Power Converter . . . . .	28
Required Tools And Equipment . . . . .	11	<b>Ground Fault Interrupter</b> . . . . .	28
<b>Towing</b> . . . . .	13	<b>Entertainment Equipment</b> . . . . .	29
<b>ON THE ROAD</b> . . . . .	14	<b>TV Antenna</b> . . . . .	29
<b>Motor Home Loading</b> . . . . .	14	<b>TV "Ghosts" And FM "Flutter"</b> . . . . .	29
Carrying Capacity . . . . .	14	Minimizing Multipath Distortion	
Weighing Your Loaded Motor Home . . . . .	14	and Improving Signal Quality . . . . .	29
Loading Tips . . . . .	15	<b>Generator Power Plant</b> . . . . .	30
Trailer Hitches And Towing . . . . .	15	<b>Generator Fuel Supply</b> . . . . .	30
Towing Automobiles . . . . .	16	<b>Generator Operation</b> . . . . .	30
<b>LIVING WITH YOUR MOTOR HOME</b> . . . . .	17	Generator Operating Safety Precautions . . . . .	31
Manual Entry Steps . . . . .	17	Warm Weather Operation . . . . .	31
Entry Doors, Screens, And Locks . . . . .	17	Cold Weather Operation . . . . .	31
Windows . . . . .	17	Preparation For Storage . . . . .	32
Mini-Blinds . . . . .	17	Reactivating Generator System After	
Emergency Exit Window . . . . .	17	Long Term Storage . . . . .	32
<b>Storage</b> . . . . .	17	Generator Maintenance And Service . . . . .	32
Exterior Compartments . . . . .	17	<b>Electrical System Wiring</b> . . . . .	32
Interior Storage . . . . .	18	<b>LPG SYSTEM</b> . . . . .	31
<b>Interior And Furnishings</b> . . . . .	18	<b>LPG Gas Safety Precautions</b> . . . . .	31
Dinette Conversion . . . . .	18	<b>System Components</b> . . . . .	3
Sofa/Lounge Conversion . . . . .	18	Hoses And Fittings . . . . .	3
Interior Lighting . . . . .	18	LP Gas Regulator . . . . .	3
Overhead Vents . . . . .	18	<b>Using LP Gas System At Low Temperatures</b> . . . . .	3
		<b>Filling LP Gas Tanks</b> . . . . .	3
		<b>LP Gas System Leak Checks</b> . . . . .	3
		<b>LPG Leak Detector</b> . . . . .	3
		<b>Lighting LP Gas Appliances</b> . . . . .	3

<b>APPLIANCES</b> .....	37
<b>Water Heater</b> .....	37
<b>Furnace</b> .....	37
<b>Range</b> .....	37
<b>Range Exhaust Hood</b> .....	38
<b>Air Conditioner</b> .....	38
<b>Refrigerator</b> .....	38
<b>Smoke Detector</b> .....	38
<b>MAINTENANCE</b> .....	39
<b>Lubrication</b> .....	39
<b>Wheels And Tires</b> .....	39
Tire Inspection And Rotation .....	39
Inflation Pressure .....	39
Wheel And Tire Balancing .....	40
Tire Replacement .....	40
<b>Engine</b> .....	40
Engine Oils .....	40
<b>Engine Fuel Systems</b> .....	40
Fuel And Air Filters .....	40
Air Cleaner Element Replacement .....	40
<b>Cooling System</b> .....	40
Maintenance And Inspection .....	40
Coolant Level .....	40
Flushing Cooling System .....	40
<b>Engine Electrical</b> .....	41
Jump Starting .....	41
<b>Transmission</b> .....	41
Maintenance and Inspection .....	41
<b>Heating And Air Conditioning</b> .....	41
Inspection .....	41

Air Conditioner Operational Quick Checks .....	41
Electrical Circuit Diagnosis .....	42
Refrigeration Section .....	42
<b>Front Suspension And Alignment</b> .....	42
<b>Brakes</b> .....	42
Brake Hose Inspection .....	42
Lining Inspection .....	42
<b>Drive Belts</b> .....	42
<b>Exterior</b> .....	42
Stains .....	43
Windows, Doors, Vents And Locks .....	43
Sealant Renewal .....	43
<b>Rubber Roof System</b> .....	43
Cleaning .....	43
Care .....	43
Door And Window Resealing .....	43
<b>Interior</b> .....	44
Upholstery And Drapes .....	44
Wall And Ceiling Panels .....	44
Floors And Carpeting .....	44
<b>PREPARING THE MOTOR HOME FOR</b>	
<b>LONG-TERM STORAGE</b> .....	45
<b>Storage Check List</b> .....	45
Short-term Storage (less than 60 days)	
Above Freezing .....	45
Long-term Storage Above Freezing .....	45
<b>Winterization And Winter Storage</b> .....	45
Winter Storage Below Freezing .....	46
Water System Winterizing .....	46
General Vehicle Winter Storage Check List .....	47
Reactivating The Motor Home After Storage ..	47
<b>MAINTENANCE CHART</b> .....	49

# INTRODUCTION

Welcome to the recreational vehicle life-style and the growing family of motor home owners. We sincerely thank you for choosing a Fleetwood motor home!

Your Tioga Arrow has been designed to provide you with many years of carefree, pleasant traveling and vacationing. This manual describes many features of your motor home and provides an operating guide so that you can obtain the best performance from those features. Your motor home has been designed to conform with, or exceed, the American National Standards Institute A119.2, NFPA 501C, Canadian CSA Standard Z-240 (units built for Canada only), and applicable motor vehicle standards. These standards establish the plumbing, heating, electrical and other requirements for quality and safety. Compliance with these standards is indicated by the seal attached just outside the entry door. This seal is the outward sign of internal quality.

Like all finely crafted equipment, your Tioga Arrow will require care and regular maintenance in order to deliver maximum value and performance. The dealer will give you basic operating and maintenance instructions; however, supplement this instruction by reading all instructional material furnished with the motor home in the Owner's Information Package and Chassis Operator's Manual. If, after taking delivery of your new motor home, you feel it requires additional conditioning or adjustment, please return it to your dealer as soon as possible. This Owner's Manual, along with the information provided in your Owner's Information Package and Chassis Operator's Manual outlines important areas of maintenance and provides a maintenance schedule for you to follow to ensure safe, troublefree service from your motor home. Study these instructions carefully before you operate the motor home for the first time. Spend some time with your dealer going over safety and operating instructions before you leave the dealer's lot. A good working knowledge of your motor home and how to care for it will help you enjoy many miles and years of recreational living.

If you have any questions regarding operation, maintenance, or service, please contact your dealer immediately so he can assist you. Your dealer's Service or Sales Department will handle any normal problems which might occur.

Your motor home is covered by one of the most comprehensive warranty programs in the RV industry, and this manual contains a section outlining the warranty and explaining your rights and obligations, as well as the rights and obligations of the dealer and manufacturer, under the terms of the warranty. Please read this section carefully. You will be better informed in case you have a warranty-related problem, and

your dealer will be better able to get you on the road again.

If there is anything about the warranty or what it does or does not cover, please contact your dealer.

The materials in your Owner's Information Package contain warranty information on the various appliances and components in your motor home. Warranty registration cards for these items should be filled out and mailed as soon as possible after you take delivery of your motor home. Your dealer can help you with this.

You will automatically receive an Ownercare Card approximately 3-4 weeks after delivery of your new Tioga Arrow. This plastic card is imprinted with your name, the motor home serial number, and manufacturing plant location. If your motor home ever needs warranty service, present this card to the dealer.

Always return your motor home to the selling dealer for warranty service. If this is not possible, you may contact any other authorized Tioga Arrow dealer, or any authorized Fleetwood motor home dealer. The service department at any of the plants listed on the inside back cover of this manual can help you find a dealer in your area.

If, for some reason, a problem is not handled to your satisfaction:

1. Discuss any warranty-related problems directly with the manager or owner of the dealership, giving him an opportunity to help his service department resolve the matter for you.
2. If a problem arises that cannot be resolved to your satisfaction by your local dealer, contact the factory service manager. The factories are listed in this manual. Please contact the one nearest you.
3. We sincerely believe that your dealer and the factory representative will be able to solve any problem which might arise. If their combined efforts are not satisfactory, please send a letter describing the circumstances to:

Fleetwood Enterprises, Inc.  
Consumer Affairs Department  
P.O. Box 7300  
Riverside, CA 92523

Please include the brand name and serial number of your motor home.

4. If you wish to call for assistance, please use these toll-free telephone numbers:

From California: (800) 442-4804  
From outside California: (800) 854-4755

**NOTE:** Some equipment and features described or shown in this manual may be optional on some models. This instructional manual is of general nature only. Because of the continuous program of product improvement conducted by Fleetwood, it is possible that recent product changes may not be included in this manual. Specifications may change without notice. The instructions included in this manual are intended as a guide, and in no respect extend the responsibilities of the manufacturing subsidiary, parent company or affiliates beyond the standard written warranty as presented in this manual.

Photographs or illustrations in this manual are representative of function and may not be specific in their depiction of actual equipment, fabrics, interior or exterior decor or design options as installed on or in your motor home.

**NOTE:** This product is designed for recreational use and short term occupancy only. It is not designed or intended to be used as permanent housing. Use of this product for long term or permanent occupancy may lead to premature deterioration of interior finishes, fabrics, carpeting, and drapes. Damage or deterioration due to long term occupancy may not be considered normal, and may under the terms of the warranty, constitute misuse, abuse, or neglect, and may therefore reduce your warranty protection. This manual contains a discussion of long term occupancy problems. Please refer to that section before considering this product for long term occupancy.

The motor home has been thoroughly inspected before shipment. **YOUR DEALER IS RESPONSIBLE FOR PERFORMING A COMPLETE PREDELIVERY INSPECTION OF THE CHASSIS AND ALL MOTOR HOME COMPONENTS AS SPECIFIED IN THE PREDELIVERY CHECKLISTS SUPPLIED BY THE MOTOR HOME MANUFACTURER AND THE CHASSIS MANUFACTURER. YOU SHOULD RECEIVE A COPY OF THESE COMPLETED CHECKLISTS FROM YOUR DEALER WHEN YOUR MOTOR HOME IS DELIVERED TO YOU.**

**AS A PART OF THE PREDELIVERY INSPECTION PROCEDURE, THE DEALER IS TO ROAD TEST THE MOTOR HOME, NOTING AND CORRECTING ANY STEERING PROBLEMS BEFORE DELIVERY. THEREFORE, FLEETWOOD AND ITS SUBSIDIARIES WILL NOT BE RESPONSIBLE FOR FRONT END ALIGNMENT AFTER THIS PREDELIVERY INSPECTION IS DONE.**

### **PLANNING AND PREPARATION**

Each year millions of Americans embark on trips using some type of recreational vehicle. Proper planning of your trip will ensure a pleasurable experience. A thorough knowledge of your RV is important if you

are going to get the most out of the convenience and safety items built into your vehicle. Be as familiar with it as you are with your personal car or truck. The booklets included in your Owner's Information Package cover details of operation for the major appliances and equipment built into your motor home for your comfort, convenience and safety. Later sections in this manual will also explain how to operate, maintain, and service important components and systems in your motor home.

### **LOADING AND WEIGHT DISTRIBUTION**

Proper loading is one of the most important considerations when traveling in an RV. Your motor home is built to safely carry a certain maximum load. For safety's sake, **NEVER OVERLOAD THE MOTOR HOME.** This manual contains a detailed section that explains proper loading and weighing of the vehicle.

### **HAVE IT ALL UNDER CONTROL**

Remember, your new motor home is a large vehicle and requires different driving skills than a passenger car. Later in this manual we'll outline some tips on how to become familiar with the handling characteristics and driving techniques that you need to know to be a safe motor home driver. Of course, don't overlook the laws of your state or province that govern driving a motor home. Your state or provincial Motor Vehicle Department can provide you with the applicable vehicle codes that spell out your rights and responsibilities as a motor home owner.

### **INSPECT AND MAINTAIN**

Follow a consistent schedule of inspection and maintenance for your motor home. Your continuing safety and comfort depend on it. This manual includes a section outlining maintenance intervals. Adherence to these schedules will minimize the possibility of failure of any important system or part of your motor home. The time spent inspecting and maintaining your motor home will provide you with many years of recreational pleasure.

### **THE OWNER'S INFORMATION PACKAGE**



*Owner's Information Package*

This package contains very valuable documents about your motor home and its components and systems. This Owner's Manual is in this package. Since this owner's manual does not cover every possible detail of equipment and options installed on or in your motor home, there are booklets and instructional material in the package that will help you safely operate, maintain and troubleshoot those items. Be sure you read all this information and understand the safety and operating instructions included in the package. Keep these references handy. If you ever decide to sell or trade your motor home, be sure the new owner gets all the material in this package.

Key No.: \_\_\_\_\_  
 \_\_\_\_\_  
 \_\_\_\_\_  
 \_\_\_\_\_  
 \_\_\_\_\_

**CHASSIS AND VEHICLE IDENTIFICATION**

Several numbers are used to identify the vehicle and components used on the vehicle. The V.I.N. or Vehicle Identification Number is the legal identification of the completed vehicle and is the number on the vehicle registration. The V.I.N. is found on the left top of the instrument panel and is visible through the windshield. Refer to this information when ordering parts from the chassis manufacturer or chassis dealer service center. The Fleetwood Identification Number (F.I.N.) is located on the certification tag located in the driver's step well. Use this number when ordering parts through your Fleetwood dealer or Service Center.

**KEYS AND LOCKS**

The keys to your motor home are pictured below. Record all key numbers and keep them in a safe place at home and in the motor home.

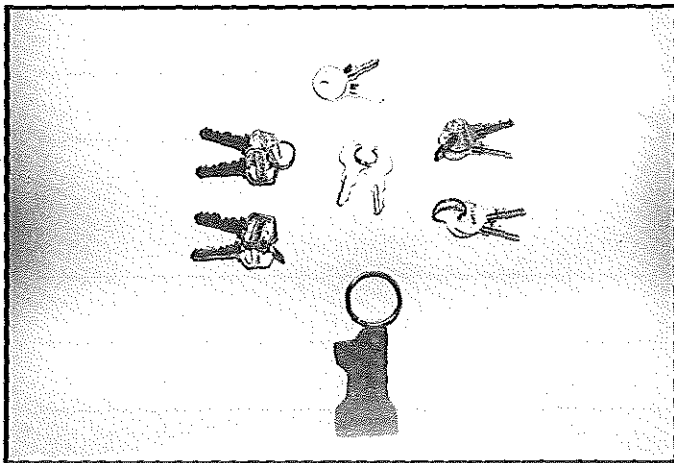

Keys

**Other Sources Of Information**

Since everyone's recreational and travel needs are different, many good publications are available for RV'ers. These books and magazines offer many tips and guidelines ranging from safe operation of your RV to regional recipe favorites, travel hints and directories of all kinds. Many of them contain first-person accounts of experienced RV'ers that can be both entertaining and informative.

The following is a list of publishers that may be of interest:

TL Enterprises  
 29901 Agoura Road  
 Agoura, CA 91300

Intertec  
 P.O. Box 12901  
 Overland Park, KS 66212

Woodall Publishing Co.  
 Box F  
 Highland Park, IL 60035

Trail-R-Club of America  
 Box 1376 B  
 Beverly Hills, CA 90213

Family Motorcoaching  
 8291 Clugh Pike  
 Cincinnati, OH 45244

Scott, Foresman & Co.  
 1909 K St. N.W.  
 Washington, D.C. 20049

Recreation Vehicle Industries Association  
 P.O. Box 2999  
 1896 Preston White Drive  
 Reston, VA 22090

# 1990 TIOPA ARROW

## EMERGENCY AND IDENTIFICATION INFORMATION

Before we explain how things work, take a few minutes to fill in the information on these two pages. It'll be a handy reference for you in the future.

Your Name \_\_\_\_\_

Model \_\_\_\_\_

Serial Number \_\_\_\_\_

Date Purchased \_\_\_\_\_

Dealer Name \_\_\_\_\_

Address \_\_\_\_\_

\_\_\_\_\_

### Insurance Policy

Company \_\_\_\_\_

Agent Name \_\_\_\_\_

Telephone \_\_\_\_\_

Policy Number \_\_\_\_\_

### Range/Oven

Manufacturer \_\_\_\_\_

Model \_\_\_\_\_

Serial Number \_\_\_\_\_

### Refrigerator

Manufacturer \_\_\_\_\_

Model \_\_\_\_\_

Serial Number \_\_\_\_\_

### Furnace

Manufacturer \_\_\_\_\_

Model \_\_\_\_\_

Serial Number \_\_\_\_\_

**Water Heater**

Manufacturer\_\_\_\_\_

Model\_\_\_\_\_

Serial Number\_\_\_\_\_

**Air Conditioner**

Manufacturer\_\_\_\_\_

Model\_\_\_\_\_

Serial Number\_\_\_\_\_

**Microwave Oven**

Manufacturer\_\_\_\_\_

Model\_\_\_\_\_

Serial Number\_\_\_\_\_

**Stereo**

Manufacturer\_\_\_\_\_

Model\_\_\_\_\_

Serial Number\_\_\_\_\_

**Generator**

Manufacturer\_\_\_\_\_

Model\_\_\_\_\_

Serial Number\_\_\_\_\_

**Miscellaneous**

Key Number\_\_\_\_\_

\_\_\_\_\_

\_\_\_\_\_

\_\_\_\_\_

\_\_\_\_\_

\_\_\_\_\_

\_\_\_\_\_

# PRE-TRAVEL CHECK LIST

## Exterior

- Disconnect water, electrical, and drain lines
- Check roof top carrier (if installed)
- Remove blocks from wheels
- Check wheel nut torque. (See Chassis Operator's Manual)
- Check LPG tank level and refill if necessary
- Check hitch and hitch ball (if installed)
- Check tires and adjust pressures if necessary
- Check batteries
- Check running lights, turn signals, interior and panel lights
- Check brakes, brake fluid, brake lights
- Check cooling system
- Check windshield wipers, washers, and washer fluid
- Retract step

## Interior

- Lower TV antenna
- Lock refrigerator door
- Turn off water heater
- Turn off water pump
- Turn off furnace
- Turn off range pilot
- Close cooktop cover
- Close roof vents
- Close all doors, drawers and windows

# COCKPIT AND DRIVER'S CONTROLS

Consult Chevrolet or Ford Chassis Operator's Manual for details.

## **Cruise Control**

See Chassis Operator's Manual.

**WARNING:** Do not use the cruise control on slippery roads or in congested traffic.

## **Auxiliary Start System**

The Auxiliary Start System permits using the auxiliary battery (see Electrical System) to start the motor home engine if the main vehicle battery is discharged. To use the Auxiliary Start System:

1. Be sure the vehicle is stopped, shift to "P" (PARK) and apply the parking brake.
2. Press and hold the Auxiliary Start switch on the instrument panel.
3. Start engine with ignition switch.
4. Release Auxiliary Start switch.

The Auxiliary Start System has no effect on the vehicle except to aid in starting the motor home engine. If the vehicle alternator is operating properly, the batteries will be recharged while driving (see Electrical System).

## **Driver/Passenger Seats**

The driver's and passenger's seats offer four position/comfort adjustments:

**CAUTION:** Do not adjust the seat position while the vehicle is in motion.

- \* **Forward/Back** — The forward/back lever is located under the front left of the seat.

Pull the lever toward the left outside of the seat to unlock. Release the lock lever to secure the seat position.

- \* **Swivel** — The swivel lock lever is located under the front right of the seat.

Lift the lever forward and up to swivel. The seat locks in the center, forward position. When unlocked, the seat will swivel freely around to the center position.

- \* **Recline** — The recliner lever is located on the right arm rest.

## **Seat Belts**

Seat belts are an important safety feature of your vehicle. For your protection, always use your seat

belts. The driver's seat and other seats designed to carry passengers while under way have been equipped with seat belts.

**WARNING:** All riders should be furnished with and use seat belts while the vehicle is in motion. Seats which are not equipped with safety belts should not be occupied while the vehicle is in motion and will be labeled: "NOT FOR USE WHILE THE VEHICLE IS IN MOTION." It is not possible to belt in persons using beds.

Adjust seat belts as follows:

- \* Pivot buckle at right angles to the belt and pull to the desired length.
- \* To fasten belt, be sure it is not twisted, then push the tongue end of one belt into the buckle of the mating belt. Be sure it latches. Adjust the belt snugly as low on the abdomen as comfort will allow, for greatest safety.
- \* To release the belt, depress the button in the center of the buckle and slide the tongue out of the buckle. Never use a belt for more than one person at a time.

## **Child Restraint**

All vehicle occupants, and especially children, should be restrained whenever riding in vehicles. Holding a child in your arms is not a substitute for a child restraint system. In an accident, a child held in a person's arms can be struck or crushed by any unrestrained rider. An unrestrained child could also be injured by striking the interior, or by being thrown from the vehicle during a sudden maneuver or impact. A child restraint system can help protect a child while riding in a vehicle. Child restraint systems are designed to be secured in the vehicle seats by lap belts or the lap portion of a lap-shoulder belt. Children could be endangered in a crash if their child restraints are not properly secured in the vehicle.

Children small enough for a child restraint system should be restrained that way if at all possible. However, the following may provide some degree of protection if a child restraint is not used.

- \* Infants who cannot sit up should be placed in a padded baby carrier. Put it crosswise on the vehicle seat and securely restrain it with the vehicle's seat belts.
- \* Children who can sit up by themselves should be restrained with the seat belts provided. Never let a child stand or kneel on any seat.

When using any child restraint system, be sure to read

and follow all instructions on installation and use that come with the system.

When securing a child restraint with a lap belt that has no retractor, pull the excess webbing through the adjustment mechanism.

If the child restraint is still not secure, use a different seating position in the vehicle and/or contact your dealer and the child restraint manufacturer for help.

### **Side Slider Windows**

Turn lock, slide window and/or screen to open and close.

**NOTE: Screens are not removable for cleaning. They may be pushed out of their frames if the window must be used for emergency exit. In this case, the screens will be destroyed and will probably have to be replaced.**

### **DRIVING AND PARKING**

Once you become accustomed to the feel of the controls and the reference points from the driver's seat, you will find driving the motor home comparable to driving your family car. Become familiar with the position of the motor home in traffic, and be cautious when maneuvering to allow for the length and width of the vehicle. Always allow extra room to corner and to change lanes. Learn to use the side mirrors to view the road behind. Check them often.

Drive with consideration on the highway, observing all speed and safety regulations. The best cruising speed of your motor home will vary with road and weather conditions.

Remember that your motor home is heavier than a car, making it less maneuverable and harder to stop. Also, because of its greater side surface area, it is more easily affected by cross winds. Allow extra distances for passing and stopping, and drive at a moderate speed, particularly in traffic and in gusty wind conditions.

Driving on winding or mountain roads is not difficult if done with reasonable care. Observe proper vehicle speeds when ascending or descending hills and always operate in the proper transmission range. Downshift on hills to avoid overheating or undue engine loads. Downshift when descending grades. Engine braking power will help control vehicle speed, and relieve some of the strain on the brakes.

Road conditions, terrain, weather, and other driving factors are sometimes unpredictable, and mountain driving or desert temperatures can put extreme demands on drivetrain components—especially the transmission. Under extreme heat conditions you may need to turn off the vehicle air conditioner to improve engine and transmission cooling.

Allow for the extra height of your motor home and avoid areas having low overhead clearance. Check for low-hanging tree branches or other obstructions whenever you drive or park. Avoid low roofs when pulling in for service. Always check overhead clearances of overpasses and bridges. This may be particularly important if you drive with the overhead vents open or if the motor home

is equipped with a roof air conditioner, roof rack, CB or TV/radio antenna.

When parking parallel to a curb, be sure to allow for poles or obstructions as the front and rear portions of the motor home swing wider than an automobile. When parking on an incline, turn the front wheels into the curb in the direction of the roll to aid the parking brake. Always shift the transmission to PARK ("P") and set the parking brake when parking.

### **FUEL AND FUEL SYSTEMS**

See the Chassis Operator's Manual in the Owner's Information Package for fuel recommendations.

#### **Fuel Fill**

The fuel filler cap is located at the rear of the coach. Modern fuel systems may build up vapor pressure within the tank as the gasoline warms during use or hot weather. Under certain conditions, sudden release of this pressure when removing the gasoline cap can spray gasoline from the fill opening, causing a possible hazard.

**WARNING: WHEN REMOVING THE GASOLINE CAP, ROTATE IT SLOWLY ONLY FAR ENOUGH TO ALLOW PRESSURE TO RELEASE. AFTER ANY "HISSING" SOUNDS STOP, COMPLETE THE REMOVAL OF THE CAP.**

To protect the gasoline system from excessive pressure or vacuum, or from sudden release of pressure, replace lost caps with caps of the same design available from your Fleetwood motor home dealer.

Clean up fuel spills immediately. Raw fuel spilled on the motor home could damage the exterior finish, and is a serious fire hazard.

#### **Fuel Types And Vapor Lock**

Today's automotive fuel and emissions systems are sophisticated and highly engineered to meet Federal and state emissions standards. They are also sometimes sensitive to fuel types and blends, particularly blends that are optimized for climatic conditions. Fuel refiners change the additives in the fuel to compensate for temperature variations during winter or summer months. This compensation changes the "vapor pressure" of the fuel. This means that the fuel vaporizes easier during the winter than it does during the summer when higher air temperatures help the fuel vaporize in the engine. Since colder temperatures reduce the fuel's ability to vaporize and burn in your engine, additives help raise the volatility of the fuel. This helps the engine start easier and run smoother during winter months. Under the best of conditions, the refiners supply their gas station customers with the correct fuel for their location and seasonal conditions. Sometimes though, fuel blended for winter is supplied during summer months.

What this all means is that there is a possibility of "vapor lock" during summer driving. This condition is a combination of new engine design (with attendant higher temperatures under the hood), and excessive fuel vaporization caused by the vapor pressure of the fuel you are using. If your engine and fuel system are properly tuned and maintained, you should not experience

vapor lock. If vapor lock occurs, the fuel itself could be the cause. If at all possible, check with the gas station attendant as to the fuel blend before filling your fuel tank. If you purchase your fuel from nationally recognized fuel dealers, your chances of vapor lock can be reduced. If you store your motor home during the winter months, avoid storing large quantities of winter blended fuel in the tank. When you take the vehicle out of storage in the spring or summer, this fuel may cause vapor lock until it is used up.

Another note on long storage — if you plan to store your motor home for a long period in conditions of widely varying humidity, consider topping off the fuel tank. This will reduce the buildup of condensation in the tank that could cause rough engine operation, fuel filter blockage, or other problems associated with water in the fuel.

**NOTE: DURING EXTENDED PERIODS OF STORAGE (60 DAYS OR MORE), GASOLINE MAY DETERIORATE DUE TO OXIDATION. THIS CAN DAMAGE RUBBER AND OTHER MATERIALS IN THE FUEL SYSTEM SUCH AS CARBURETOR ACCELERATOR PUMP, DIAPHRAGMS, AND CARBURETOR INLET VALVES. IT MAY ALSO CLOG SMALL ORIFICES.**

**A COMMERCIALY AVAILABLE GASOLINE FUEL STABILIZER MAY BE ADDED TO GASOLINE-POWERED VEHICLES WHENEVER ACTUAL OR EXPECTED STORAGE PERIODS EXCEED 60 DAYS.**

**FOLLOW ADDITIVE MANUFACTURER'S INSTRUCTIONS. OPERATE THE VEHICLE REGULARLY DURING THE STORAGE PERIOD TO MIX AND CIRCULATE THE ANTI-OXIDANT AGENT THROUGHOUT THE FUEL SYSTEM.**

### **Alternative Fuel Types**

Gasohol, a mixture of ethanol (grain alcohol), or methanol and gasoline may be used in your motor home engine without voiding the warranty. However, **DO NOT UNDER ANY CIRCUMSTANCES USE FUEL BLENDS CONTAINING MORE THAN 5% METHANOL OR 10% ETHANOL, AND DO NOT USE BLENDS THAT CONTAIN BOTH METHANOL AND ETHANOL.** Any fuel blend you use containing alcohol must also contain cosolvents and other additives to protect the fuel system components. If you are not sure of the composition of the alcohol/gasoline blend you intend to use, ask your service station operator. Discontinue use of any alcohol/gasoline blend if driveability or fuel system problems occur.

Chemical reactions between the fuel components and the materials in the fuel lines can cause deterioration of the fuel lines during storage periods. These effects are especially noticeable with gasohol blends. If you plan to use alcohol blended fuel, and expect to store your motor home for periods of 60 days or more, add a fuel additive that is formulated to counteract these oxidation effects. Your dealer can advise you on the proper additives and their use.

If gasohol is spilled on a painted surface, some dulling or softening of the paint may result.

### **Overheating**

Operate and service the engine and cooling systems in your vehicle as recommended in the Chassis Operator's Manual.

### **ENGINE EXHAUST SYSTEM COMPONENT HEAT**

Your motor home engine has been designed to conform with Federal and State emission requirements. To meet these requirements, engine operating temperatures are high. As a result, the engine and exhaust system components radiate a great deal of heat. Parts of the exhaust system may operate at temperatures near 700 degrees F. These temperatures are normal for your vehicle.

Special heat shields may be built into your vehicle to protect wiring or other components from possible heat damage caused by the exhaust system. Do not modify or remove these shields without consulting your RV dealer. If you want to install equipment, add wiring, plumbing, or other components near the exhaust system or the heat shields, do so only after your thoroughly investigate and understand how the equipment will be affected by the heat radiated by the exhaust system.

### **CARBON MONOXIDE SAFETY PRECAUTIONS**

Carbon monoxide is a colorless, tasteless, odorless gas. It is a by-product of combustion in engine(s). The engines in your motor home and generator system (if installed) produce it constantly while they are running. **CARBON MONOXIDE IS DEADLY.** Please read and understand the following precautions to protect yourself and others from the effects of carbon monoxide poisoning.

**WARNING: EXHAUST GASES ARE DEADLY. DO NOT BLOCK THE TAILPIPES OR SITUATE THE VEHICLE IN A PLACE WHERE THE EXHAUST GASES HAVE ANY POSSIBILITY OF ACCUMULATING OUTSIDE, UNDERNEATH, OR INSIDE YOUR VEHICLE OR ANY NEARBY VEHICLES. OUTSIDE AIR MOVEMENTS CAN CARRY EXHAUST GASES INSIDE THE VEHICLE THROUGH WINDOWS OR OTHER OPENINGS REMOTE FROM THE EXHAUST OUTLET. OPERATE THE ENGINE(S) ONLY WHEN SAFE DISPERSION OF EXHAUST GASES CAN BE ASSURED, AND MONITOR OUTSIDE CONDITIONS TO BE SURE THAT EXHAUST CONTINUES TO BE DISPERSED SAFELY.**

Beware of exhaust gas (carbon monoxide) poisoning symptoms:

- Dizziness
- Intense Headache
- Weakness and Sleepiness
- Vomiting
- Muscular Twitching
- Throbbing in Temples

If symptoms indicate the possibility of carbon monoxide poisoning, turn off the engine(s) immediately, get out into fresh air at once, and summon medical assistance.

**WARNING: DO NOT UNDER ANY CIRCUMSTANCES OPERATE ANY ENGINE WHILE SLEEPING.**

You would not be able to monitor outside conditions

to assure that engine exhaust does not enter the interior, and you would not be alert to exhaust odors or symptoms of carbon monoxide poisoning.

During stops while traveling, inspect the exhaust systems for road damage. Do not operate an engine with a damaged exhaust system.

Check the exhaust system(s) during routine maintenance, and repair any leaks, damage, or obstructions before further operations.

Do not modify the exhaust system(s) in any way without first consulting the RV manufacturer.

### **SAFETY TIPS**

Read and understand the Chassis Operator's Manual.

When backing the motor home, have a person stand to the rear on the driver's side to guide you.

Before departing on a trip, check your routes. Remember, some tunnels prohibit motor homes with LP gas systems.

Drive at moderate speeds, particularly in traffic and in gusty wind conditions.

Allow extra distance for passing and stopping.

While traveling, make sure all occupants use their seat belts.

While traveling, make sure all doors are closed and cabinets, drawers, and loose objects are secure.

Instruct your family on what to do in case of fire, and hold fire drills periodically.

Maintain proper charge in the fire extinguisher.

Gas detectors are available from RV equipment dealers, and may be considered as safety accessories.

Keep a well stocked first-aid kit handy.

Keep a tool box handy.

Check tires often while traveling. Inside rear duals should receive special attention, as these tires may go flat and not be noticed. Running a flat on an inside dual could lead to a tire fire that would be extremely difficult to extinguish. Make it a habit to check tire pressures with an accurate tire gauge before each trip, and when refueling give each tire a sharp rap on the tread surface with a hammer or similar object. Properly inflated tires produce a "bung" sound when rapped. If the tire is flat, the sound will be a dull "thud".

### **ENGINE ACCESS**

The top of the engine may be accessed for service by removing the engine cover.

**WARNING: WHEN INSTALLING THE ENGINE COVER, BE SURE THE COVER IS FULLY SEATED ON THE GASKET SEAL AND SECURED BY THE COVER SCREWS. DO NOT ALLOW CARPETING, FLOOR MATS OR OTHER MATERIAL TO INTERRUPT THE SEAL BETWEEN THE COVER AND THE ENGINE COMPARTMENT. IF THE ENGINE COVER IS NOT INSTALLED CORRECTLY, ENGINE EXHAUST GASES COULD LEAK INTO THE PASSENGER COMPARTMENT CREATING A SAFETY HAZARD. IF THE ENGINE MUST BE RUN WITH THE ENGINE**

**COVER OFF FOR MAINTENANCE PURPOSES, BE SURE THE VEHICLE INTERIOR IS ADEQUATELY VENTILATED.**

### **TIRES**

Your motor home is equipped with truck tires. Under normal circumstances and with proper maintenance, you should receive thousands of miles of troublefree service.

For safety and maximum tire life, proper inflation pressure must be maintained. Motor home stability is also affected significantly by tire pressure, and properly inflated tires contributes to overall motor home stability and safety. The load range and maximum inflation pressure are stamped on the tire side wall. Keep tires inflated to this rated cold pressure.

**WARNING: CHECK TIRE PRESSURES OFTEN. ALWAYS CHECK PRESSURE WHEN TIRES ARE COLD, AND DO NOT BLEED AIR OUT OF WARM TIRES. FOLLOW THE TIRE PRESSURE INSTRUCTIONS IN THE CHASSIS OPERATOR'S MANUAL.**

**WARNING: KEEP TIRES PROPERLY INFLATED. A TIRE THAT IS RUN LONG DISTANCES OR AT HIGH SPEEDS WHILE SERIOUSLY UNDER-INFLATED WILL OVERHEAT TO THE POINT WHERE THE TIRE MAY LOSE AIR SUDDENLY AND/OR CATCH FIRE, POSSIBLY RESULTING IN DAMAGE TO THE VEHICLE AND ITS CONTENTS AND/OR PERSONAL INJURY.**

**NOTE: CHECK THE WHEEL COVERS PERIODICALLY. THEY COULD WORK LOOSE DURING DRIVING.**

### **Tire Replacement**

Replacement tires must be the same size, type (i.e. bias, radial, etc.) and have at least the same weight carrying capacity as the original equipment. Consult your tire dealer. The original equipment tires supplied on your motor home have weight carrying capacities to support gross axle weight ratings (GAWR) as stated on the Federal Certification Tag located on the sidewall near the driver's seat.

Refer to the Federal Certification Tag for specific axle capacities for your motor home.

### **If You Get A Flat Tire**

In case of sudden tire failure, avoid heavy brake application. Gradually decrease speed. Hold steering wheel firmly and move slowly to a safe, off-road place. Park on a firm, level spot, turn off the ignition, and turn on the hazard flasher system.

### **Changing A Flat Tire**

CONSULT THE CHASSIS OPERATOR'S MANUAL FOR INFORMATION ON TIRE CHANGING.

**WARNING: TO AVOID PERSONAL INJURY AND/OR PROPERTY DAMAGE IF A BLOWOUT OR OTHER TIRE DAMAGE OCCURS, OBTAIN EXPERT TIRE SERVICE HELP. IF YOU CHOOSE TO REMOVE WHEELS AND CHANGE THE TIRE WITHOUT PROFESSIONAL HELP, TAKE OFF THE TIRE AND RIM ASSEMBLY AND PUT ON THE SPARE TIRE AND RIM ASSEMBLY FOLLOWING THE INSTRUCTIONS**

IN THIS MANUAL AND THE CHASSIS OPERATOR'S MANUAL. DO NOT REINFLATE A TIRE THAT HAS BEEN FLAT, OR IS SERIOUSLY LOW ON AIR. HAVE THE TIRE REMOVED FROM THE WHEEL AND CHECK THE TIRE FOR DAMAGE. NEVER ADD AIR TO TIRES UNLESS AN ACCURATE PRESSURE GAUGE IS USED.

Even with good tire maintenance and normal driving, you may experience a flat tire. It is strongly recommended that you summon professional help through your auto club or travel service, or a local truck service facility. However, if you choose to change the tire yourself, there are several items that you **MUST** consider:

- \* Your motor home is built on a van chassis, and therefore rides on truck wheels and tires. These tires and wheels can weigh up to 100 pounds or more each. IF YOU ARE NOT PHYSICALLY CAPABLE OF LIFTING AND MOVING 100 POUNDS OR MORE, DO NOT UNDER ANY CIRCUMSTANCES ATTEMPT TO CHANGE A FLAT TIRE.
- \* Truck tires and wheels are installed with the wheel nuts very tight. IF YOU ARE NOT CAPABLE OF BREAKING LOOSE NUTS THAT HAVE BEEN TIGHTENED WITH UP TO 140 LB./FT. OF TORQUE, AND THEN RE-TIGHTEN TO THIS TORQUE, DO NOT UNDER ANY CIRCUMSTANCES ATTEMPT TO CHANGE A FLAT TIRE.
- \* It is **IMPERATIVE** that the motor home and jack be placed on a level, firm surface. If the motor home cannot be moved to such a location, **DO NOT** attempt to use the jack.
- \* The motor home with all of your travel gear is extremely heavy. The axle jack furnished with your motor home is capable of lifting the weight on one-half of one axle, or about one-fourth of the total gross weight of the vehicle.
- \* Carefully review all jacking and tire changing information and instructions (including this manual, the appropriate chassis operator's manual, and the jack itself), and insure that you have all required tools and equipment (listed below).

### Required Tools and Equipment

Supplied with Motor Home:

- \* Jack with minimum 4-ton capacity.
- \* Lug wrench to fit wheel nuts.

Owner-Supplied:

- \* Breaker bar handle. Note: Two feet or longer will facilitate wheel nut removal and installation.
- \* Torque wrench with at least 140 lb./ft. capacity.
- \* At least two wheel blocks.
- \* Utility block.

**WARNING: THE JACK IS DESIGNED FOR USE AS A TOOL FOR TIRE CHANGING ONLY. IT IS NOT INTENDED FOR USE AS A LEVELING DEVICE OR TO LIFT THE VEHICLE FOR SERVICE PURPOSES. DO NOT LEAVE THE JACK IN A RAISED OR LOADED POSITION FOR EXTENDED PERIODS OF TIME. NEVER START THE ENGINE WHILE THE VEHICLE IS RAISED.**

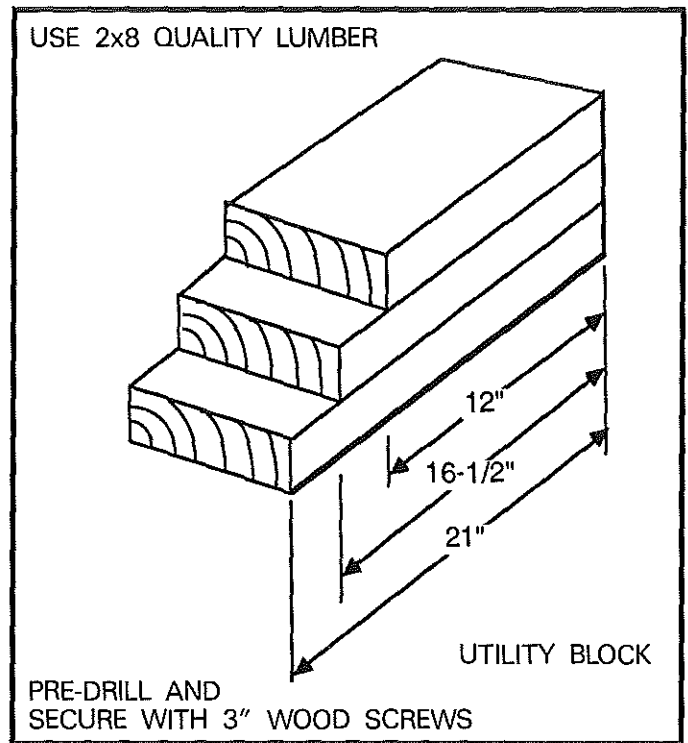

### FORD CHASSIS

Consult the Ford Owner's Manual for jacking instructions and information on tire changing.

**WARNING: DO NOT PUT ANY PORTION OF YOUR BODY UNDER THE MOTOR HOME AFTER REMOVING THE WHEEL NUTS OR WHEEL.**

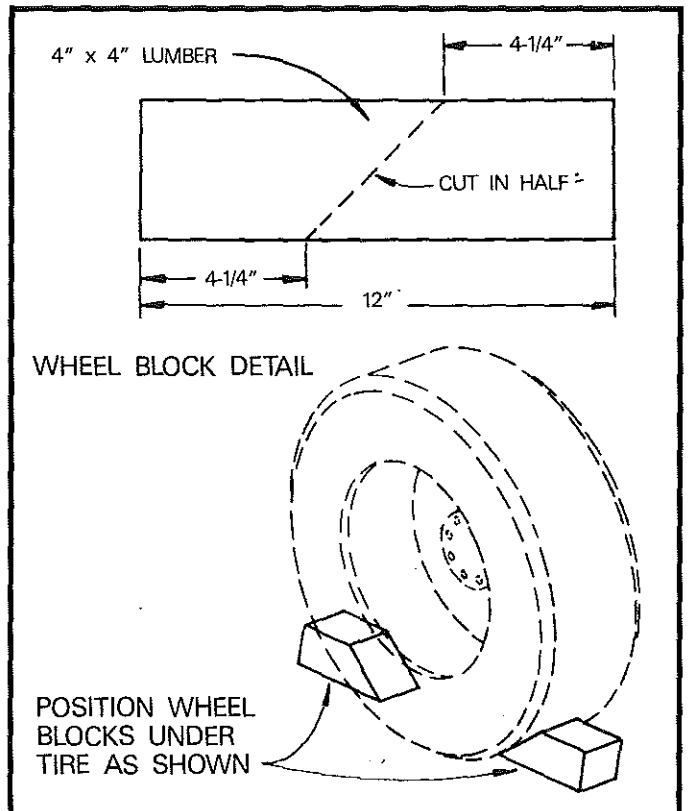

Wheel Blocks

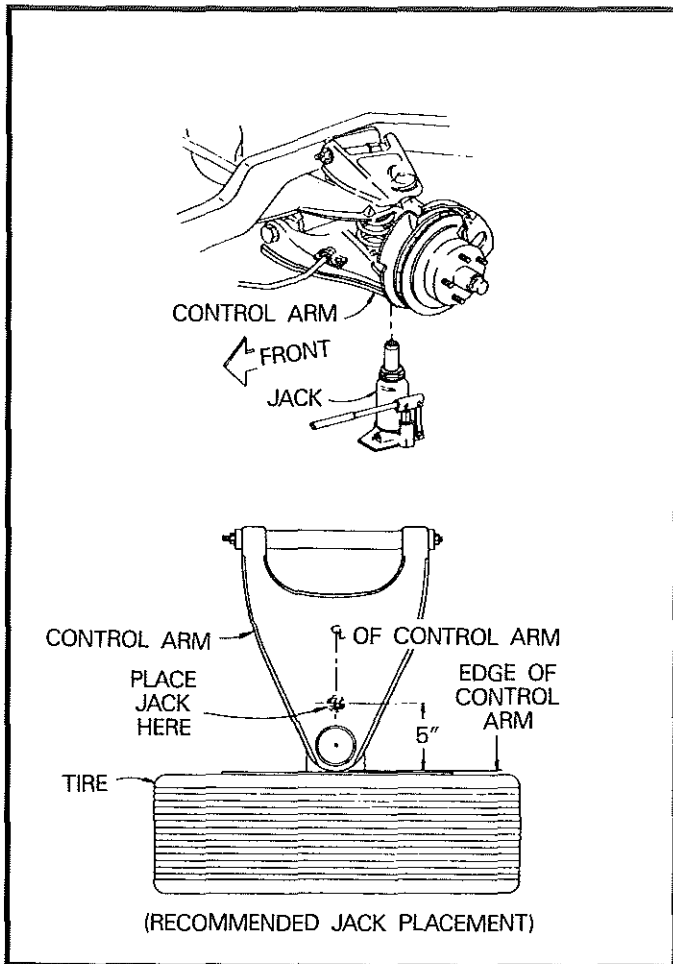

Jack Position — Front Chevrolet Chassis

### Chevrolet Chassis

Consult the Chevrolet Owner's Manual for jacking instructions and information on tire changing. Supplement with the following:

#### To Change A Front Tire:

1. Move the vehicle to a level, firm surface.
2. Remove spare tire, jack, and jacking tools and equipment from the storage area. Carefully read all instructions, including those in the Chevrolet Owner's Manual.
3. Make sure that all passengers and pets have exited the vehicle.
4. To provide clearance for the jack, carefully drive the flat tire up on the utility block.
5. Place the transmission selector in "P", set the parking brake, and turn off the engine.
6. Block both the front and back of the wheel in the opposite corner from the wheel to be changed, as shown in the illustration.

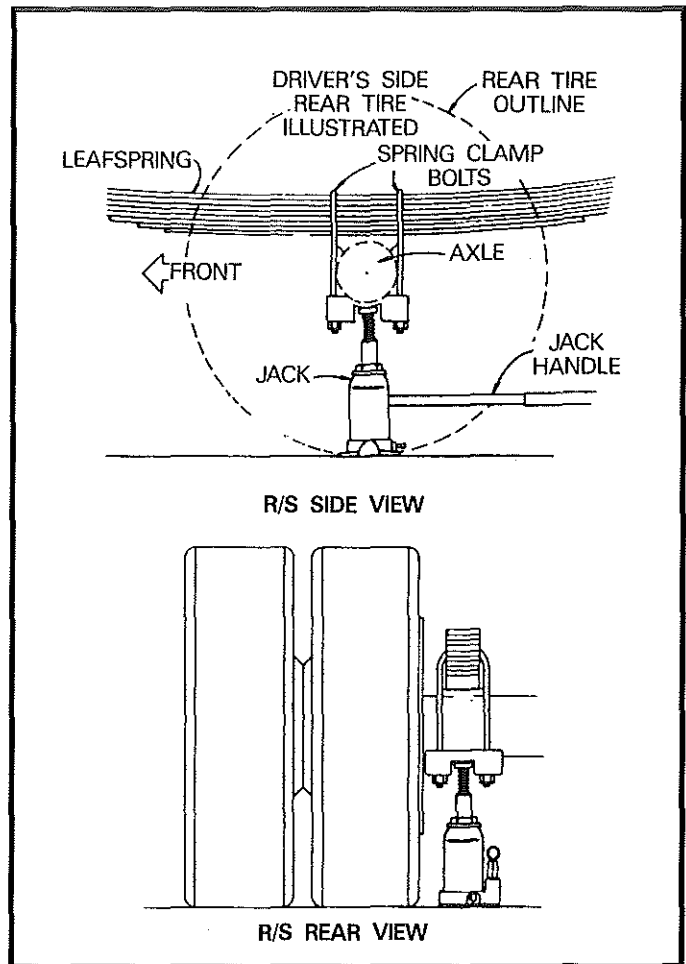

Jack Position — Rear Chevrolet Chassis

7. Adjust screw extension to an overall jack height of 10". Slide extended jack into position under the front control arm (see illustration).
8. Begin jacking until the jack engages the control arm surface, but do not lift the tire off the utility block.
9. Loosen the wheel nuts one complete turn. Do not remove.
10. Raise the vehicle until the flat tire clears the utility block.

**WARNING: DO NOT PUT ANY PORTION OF YOUR BODY UNDER THE MOTOR HOME AFTER REMOVING THE WHEEL NUTS OR WHEEL.**

11. Remove and replace tire and wheel assembly as specified in the chassis owner's manual. Remove utility block prior to installing spare wheel.
12. Completely lower and remove the jack. Remove blocks and other tools.
13. Replace wheel cover, if necessary. Note: Check the tightness of the wheel nuts often until you get to a tire service center. Have the wheel nut torque and air pressure checked by professional tire service personnel.

## To Change A Rear Tire::

(If only one of the four tires on the rear dual axle is flat, the motor home may be driven to a garage where the tire may be changed. **CAUTION:** In such an event, you should drive 25 MPH or less for no more than 5 miles, checking the tire often.)

1. Move the vehicle to a level, firm surface.
2. Remove spare tire, jack and jacking tools and equipment from the storage area. Carefully read all instructions, including those in the chassis owner's manual.
3. Make sure that all passengers and pets have exited the vehicle.
4. Place the transmission selector on "P", set the parking brake, and turn off the engine.

**WARNING: WHEN THE DUAL REAR WHEELS ON ONE SIDE OF THE VEHICLE ARE LIFTED OFF THE GROUND, NEITHER THE AUTOMATIC TRANSMISSION P(PARK) POSITION NOR THE MANUAL TRANSMISSION R(REVERSE) POSITION WILL PREVENT THE VEHICLE FROM MOVING AND POSSIBLY SLIPPING OFF A JACK, EVEN IF THOSE POSITIONS ARE PROPERLY ENGAGED.**

5. To prevent inadvertent vehicle movement while changing a tire, always set the parking brake fully and always block both the front and back of the wheel in the opposite corner from the wheel being changed, as shown in the illustration.
6. Position the jack on the second tier of the utility block. Place under leaf spring forward of the axle (see illustration). Adjust screw extension until it contacts center of leaf spring.
7. Begin jacking until the jack engages the leaf spring, but do not lift the tire off the ground.
8. Loosen the wheel nuts one complete turn. Do not remove.
9. Slowly raise the vehicle until the flat tire clears the ground, and there is adequate clearance for the inflated spare tire.

**WARNING: DO NOT PUT ANY PORTION OF YOUR BODY UNDER THE MOTOR HOME AFTER REMOVING THE WHEEL NUTS OR WHEEL.**

10. Remove wheel nuts and wheel(s), following instructions in the chassis owner's manual. Remember, with dual wheels, both wheels will be loose. Remove and replace wheels and nuts carefully.
11. Put spare wheel in place. Replace outside dual, if necessary. The dual wheels **MUST** line up properly. A special alignment stud and hole are machined into the wheel mounting flange. If the stud and hole are not aligned, the wheel will wobble enough to cause damage to tires and bearings, with possibility of wheel or tire failure.
12. Replace wheel nuts. Carefully hand-tighten the nuts snugly in sequence as indicated in the chassis operator's manual.

13. Lower the vehicle until the tire contacts the ground. Do not put the full weight of the vehicle on the tire.
14. Apply the specified torque to all nuts in sequence.
15. Lower the jack. Remove jack, blocks and other tools and equipment.
16. Replace wheel cover, if necessary. Check the tightness of the wheel nuts often until you get to a tire service center. Have the wheel nut torque and air pressure checked by professional tire service personnel.

## TOWING

If your motor home ever needs to be towed:

SEE CHASSIS OPERATOR'S MANUAL.

\* Secure any loose or protruding parts of the disabled vehicle.

\* Inspect points of attachment to the disabled vehicle.

If attachment points are damaged or deteriorated, select other attachment points at a substantial frame structural member.

\* Never allow anyone to go under a vehicle while it is being lifted by towing equipment unless the disabled vehicle is adequately supported by safety stands.

Do not tow the motor home from the rear. Towing from the rear will cause the front tires and suspension to be seriously overloaded, possibly resulting in tire or front suspension failure. The rear frame extensions are not designed to withstand the loads imposed by lifting from the rear.

If the rear wheels are disabled, place the motor home on flat bed trailer, or use a heavy duty dolly under the rear wheels and tow from the front.

**NOTE: IF YOUR MOTOR HOME MUST BE TOWED, PREVENT DAMAGE BY HAVING THE TOW TRUCK DRIVER FOLLOW THE INSTRUCTIONS IN THE CHASSIS OWNER'S MANUAL.**

The vehicle may be towed on the rear wheels with the parking brake released and the transmission in neutral provided a speed of 35 MPH and a distance of 50 miles is not exceeded. If this speed or distance must be exceeded, disconnect the driveshaft or place the rear wheels on a dolly. **DO NOT TOW ANY VEHICLE AT SPEEDS OVER 50 MPH.**

The safety of the operator and all others in the vicinity of the tow truck and the towed vehicle must be considered at all times during a towing operation. **DO NOT ALLOW ANY PERSON TO RIDE IN THE TOWED VEHICLE.** Safe operating speeds depend on weather, road, traffic, visibility conditions, and the condition of the towed vehicle. Avoid panic stops. Obey all state and local laws regarding items such as warning signals, night illumination, speed, etc.

# ON THE ROAD

## **MOTOR HOME LOADING**

Even though your motor home is built on a van chassis, there are limitations to how much it can hold and carry. These limitations are called Gross Vehicle Weight Rating (GVWR) and the Gross Axle Weight Rating (GAWR).

The GVWR is the maximum load the motor home is designed to carry. This includes everything — the body, all interior furnishings, your belongings, passengers, fuel, fresh water, waste water — attached to or carried in the vehicle. GVWR limits are governed by the structure and materials used in the chassis, frame, axles, bearings, and tires.

The GAWR is the maximum load that either the front or rear axle is designed to carry. The GVWR is equal to or slightly less than the sum of the front and rear axle GAWRs. The total of the axle loads must not exceed the overall GVWR.

The GVWR and the front and rear GAWRs for your motor home are shown on the certification tag posted on the driver's step well. Remember, these ratings are for a fully loaded vehicle. To find out how much load you can carry, you have to weigh your motor home empty, and compare the empty weight readings with the GVWR ratings. Do this initial weighing with the water, holding tanks and fuel tank(s) as close to empty as possible. Water and gasoline are heavy and can make the motor home seem heavier than it really is. Weigh without passengers. When you weigh, get out of the motor home. The weight of even one person can influence the scale readings. Weigh at an accurate and certified weigh station that uses platform scales suitable for trucks. Consult your telephone directory for weigh stations in your area. The difference between the empty weight and the weight of the motor home in traveling configuration is your usable load. If the loaded weight of your motor home exceeds the GVWR or the weight on any axle exceeds that axle's GAWR, the motor home is overloaded and you'll have to remove items to bring the weight down to or below the GVWR and GAWRs.

## **Carrying Capacity**

During the design and development of our motor homes, the number and size of storage compartments and the liquid tank capacities are maximized for value and convenience. If the motor home operator fills all liquid tanks to capacity, fills all storage compartments and cupboards to maximum volume and fills all available seating positions with passengers, the motor home will probably be overloaded. According to National Highway Traffic Safety Administration figures, an average vehicle occupant weighs 150 pounds, each gallon of gasoline weighs six pounds and each gallon of water weighs over eight pounds. The operator is

responsible for analyzing the conditions in which the motor home will be utilized for each trip.

The number of passengers and placement of cargo will affect the amount of water and cargo that you can carry (See Loading Tips). For convenience, the passenger capacity for camping use and the passenger capacity for day use are shown on the permanent table in the driver's area or adjacent to the main entry door. The smaller passenger capacity for camping provides reasonable cargo capacity for trips taking more than one day. The larger passenger capacity for day use provides less cargo capacity for trips or activities not involving overnight stays. It may be necessary to reduce the amount of water carried and unload some cargo items normally carried for camping in order to provide carrying capacity for the additional day use passengers.

Thoughtful consideration of the weight placed in the motor home can yield important benefits:

- \* maximum flexibility in the use of the liberal storage facilities provided in the motor home;
- \* improved handling characteristics and ride comfort;
- \* better fuel mileage and reduced tire wear.

## **Weighing Your Loaded Motor Home**

1. Drive the front wheels onto the scale platform and take a reading. This is the front Gross Axle Weight. (Reading 1).
2. Drive the entire vehicle (both axles) onto the scale and take a reading. This is the Gross Vehicle Weight (Reading 2).
3. Drive forward until only the rear axle is on the platform and take a reading. This reading is the rear Gross Axle Weight (Reading 3).
4. Compare reading 2 with the GVWR (Gross Vehicle Weight Rating) of your vehicle. This rating is located on the certification tag. If the reading exceeds the GVWR rating, you will have to reduce the total vehicle load.
5. If reading 2 is less than the GVWR of your vehicle, check readings 1 and 3 to verify that each is less than the GAWR on the certification tag. If either exceeds the GAWR for the axle, redistribute enough of the load to ensure that loads on the front and rear axles are within the required limit.
6. Since the placement of cargo on each side of the motor home is important, each side of the motor home should also be weighed. This will require positioning both wheels on each side down the center of the scale platform and taking a reading for each side. The attendant will help you with proper positioning.

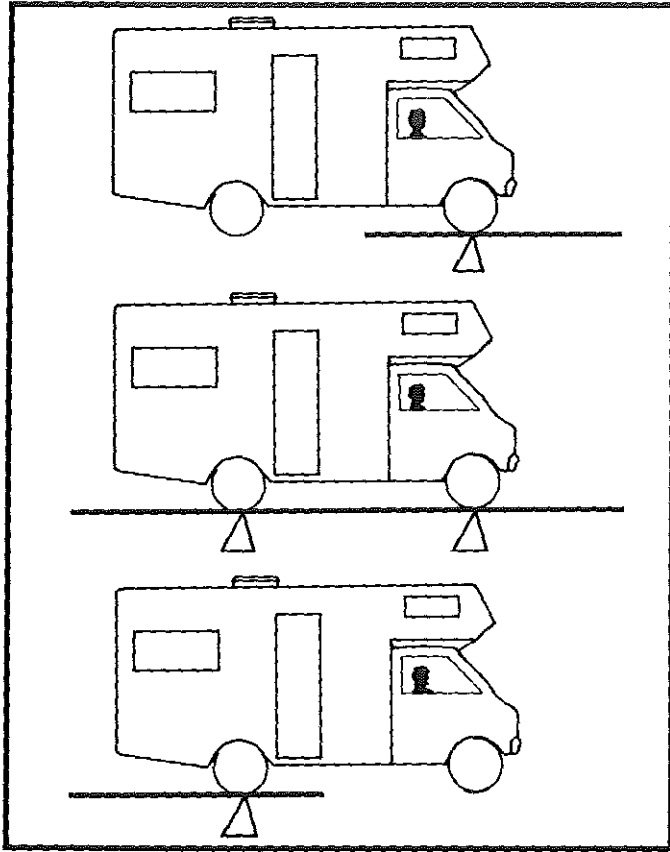

Periodically reweigh your motor home. Different traveling configurations may change your loading and weight pattern.

**WARNING: DO NOT EXCEED THE RATED LOAD OF THE MOTOR HOME, OR THE RATED LOAD OF ANY AXLE.**

**NOTE: CARRYING CAPACITIES OF YOUR MOTOR HOME ARE SPECIFIED ON A LABEL AFFIXED TO THE INSIDE OF A WARDROBE DOOR. THE LABEL INCLUDES ALL FACTORY INSTALLED OPTIONS. IF OTHER EQUIPMENT SUCH AS LEVELING JACKS, AWNINGS, ROOF PODS, ETC., ARE INSTALLED AFTER THE MOTOR HOME LEAVES THE FACTORY, THE WEIGHT OF THESE ITEMS MUST BE SUBTRACTED FROM THE TOTAL OF THE PASSENGER AND CARGO CARRYING CAPACITIES. IF YOU TOW A TRAILER, THE TONGUE WEIGHT OF THE TRAILER MUST BE SUBTRACTED FROM THE TOTAL OF THE PASSENGER AND CARGO CARRYING CAPACITIES.**

### **Loading Tips**

After you have determined how much weight you can safely carry and selected those items to make up that weight, make a list and keep it for future reference. Load the motor home and distribute the load so that you get proper weight on the axles. Do not load upper cabinets with heavy items. Secure and brace items so they won't move during travel, thereby shifting the load in the motor home. Do not load heavy items near either end of the

motor home or on the rear bumper. Adjust cargo storage to keep the side to side wheel loads as equal as possible. Carry only as much water as needed for travel use or to balance the load. Whenever possible, empty the holding tanks before traveling.

**WARNING: DO NOT INSTALL ANY TYPE OF WEIGHT CARRYING RACK OR FRAME TO THE REAR BUMPER OR ANY CHASSIS OR BODY COMPONENT OF THE MOTOR HOME. DAMAGE TO THE MOTOR HOME BODY AND UNSTABLE HANDLING CHARACTERISTICS MAY RESULT.**

**WARNING: EXCEEDING THE GAWR OR GVWR OF YOUR MOTOR HOME CAN CAUSE UNDESIRABLE HANDLING CHARACTERISTICS AND MAY CREATE A SAFETY HAZARD. MODIFICATION OF YOUR VEHICLE BY ADDITION OF RACKS NOT SPECIFIED BY THE MANUFACTURER TO CARRY ADDITIONAL EQUIPMENT OR VEHICLES IS NOT RECOMMENDED, MAY CREATE A SAFETY HAZARD, AND MAY VOID YOUR WARRANTY.**

Make a loading diagram of your properly loaded motor home. It will help you locate where specific items are stored, and will help speed the loading process. Store emergency items in a readily accessible location. Include tools, first-aid kit, rain gear, flashlight, highway warning devices, and an electric cord with light.

**WARNING: DO NOT STORE OR CARRY LP GAS CONTAINERS, GASOLINE, OR OTHER FLAMMABLE LIQUIDS INSIDE YOUR MOTOR HOME.**

### **Trailer Hitches And Towing**

If you expect to pull a trailer with your motor home, please use these guidelines when choosing a hitch and trailer:

- \* Hitch classification: Class II
- \* Limit the vertical hitch load (tongue weight of trailer) to a maximum of 250 pounds. Heavier vertical hitch loads can cause damage to your motor home rear frame and body, cause unstable driving and handling characteristics, and may restrict your rights under the Ownercare warranty.
- \* Do not tow a trailer weighing more than 3500 pounds, or more than recommended by the chassis manufacturer, whichever is less. Heavier trailers can cause damage to the motor home structure or drive train, cause unstable driving or handling characteristics, or restrict your rights under the Ownercare warranty.
- \* Consult your chassis manufacturer dealer for the Gross Combined Weight Rating (GCWR) of the motor home chassis. The GCWR is the total weight of the fully loaded motor home with driver, all passengers and all cargo, and the fully loaded trailer.
- \* Information on specific combinations of engines, axle ratios, and Gross Combined Weight Ratings applicable to towing situations is available through your dealer

or from the chassis manufacturer. Ask for the chassis manufacturer's "Towing Guide" that applies to your vehicle.

- \* Alternate gear ratios may be available for special towing needs. Contact your local chassis manufacturer dealer for recommendations. Exceeding these GCWR's may cause damage to your motor home drive train or chassis, unstable driving and handling characteristics, and may void your warranty.
- \* Weigh your motor home fully loaded with driver, passengers, cargo, and the fully loaded trailer attached. Do not exceed the Gross Axle Weight Rating (GAWR) of any axle, and do not exceed the Gross Vehicle Weight Rating (GVWR) of either the motor home or the trailer, or the Gross Combined Weight Rating

(GCWR) of the motor home. If any of these ratings are exceeded, weight must be eliminated or shifted until scale weights are equal to or less than ratings.

### ***Towing Automobiles***

If you plan to tow an automobile with your motor home, the tongue weight must not exceed 250 pounds. The Gross Combined Weight must not exceed the GCWR.

**CAUTION: Towing devices (other than wheeled dollies) that raise the front or rear wheels of the vehicle in tow off the ground create tongue weights in excess of the 250 pounds maximum, and must not be used.**

# LIVING WITH YOUR MOTOR HOME

## **Manual Entry Steps**

Entry steps are located under each entry door.

To extend the manual step:

Pull complete step assembly out; let it down completely.

## **Entry Doors, Screens, and Locks**

Entry door locks and deadbolts are keyed separately. Be sure to record all key numbers and keep them in a safe place.

The screen door may be separated from the main entry door by depressing the catch. A holdback mechanism will secure the main door against the side of the motor home.

## **Windows**

Windows in your motor home are either slider or torque pane type. Slider windows may be locked by turning the lock knob. Torque windows may be opened and adjusted by turning the knob or crank located at the bottom of the window.

## **Mini-Blinds**

To raise mini-blinds: Release bottom of blind from retainer. Pull straight down on cord and release at desired height. It is not necessary to pull the cord to one side or the other to secure blind.

To lower mini-blind: Pull straight down on the cord slightly, and move it about 45 degrees to either the left or right and lower the blind. Stop the blind in mid-travel by moving it back to the straight down position. Reattach the retainers when traveling.

To adjust the angle: Turn the adjusting rod either direction.

## **Emergency Exit Window**

The emergency exit window provides an escape route in case the motor home must be evacuated under emergency conditions. To operate the window, pull the red handle(s) and push the window out. The window will fall to the ground. The window may be removed for cleaning, but be sure to catch it after releasing the handles.

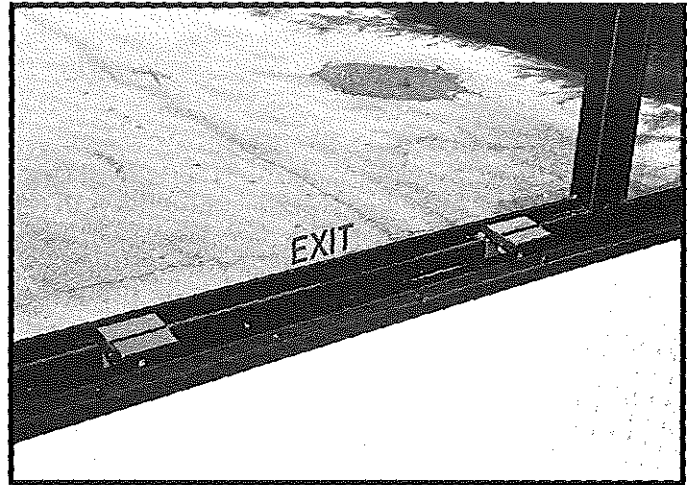

*Emergency Exit Window*

## **STORAGE**

### **Exterior Compartments**

Exterior storage compartments maximize available space and should accommodate most of your storage needs. They have been designed to remain secure while the vehicle is in motion. All of the storage compartments except the LP gas and generator compartment can be locked. Fire-prevention regulations require that the LP gas and generator compartment be unlocked at all times.

The exterior compartments are large. Please note that if all compartments are filled with heavy, or densely packed items, your motor home could be overloaded. Refer to the section in this manual that discusses capacity and weighing. Follow the loading and weighing instructions in that section.

When storing equipment and supplies:

- \* Always keep tools and equipment stored in areas where they will not shift while traveling.
- \* Whenever possible, place heavy articles in storage compartments which are low and in the best location for better weight distribution. See "WEIGHING" section.
- \* Pack articles carefully in the storage compartments to minimize shifting. If necessary, use straps to prevent movement.

- \* Be sure liquid containers are capped and cannot tip or spill. Secure all glass containers and dishes before traveling.
- \* Exterior storage compartments may not be water-tight in all climate conditions. Carry any articles which could be damaged by water inside the motor home.

**WARNING: OUTSIDE STORAGE COMPARTMENTS ARE NOT SEALED, VENTED ENCLOSURES, AND MAY BE ACCESSIBLE FROM INSIDE THE MOTOR HOME. DO NOT STORE FLAMMABLE, VOLATILE LIQUIDS, HAZARDOUS CHEMICALS OR EQUIPMENT IN THESE AREAS.**

### *Interior Storage*

Interior storage areas may be found in a number of places in your motor home — overhead compartments, wall closets, under the dinette, under the bed, lav and galley cabinets. Most of the closets and cabinets have hidden latches along one edge of the door. Press the latch button to open the door. Overhead doors may have friction supports to hold them open.

Drawers rest in detent notches when they are closed. To open drawers, lift up slightly, then pull open.

Closets may be equipped with 12-volt lights that may be switched to turn ON when the closet door is opened. Be sure the light goes OFF when you close the closet door — your battery could be discharged rapidly if it stays ON. If the light stays on when the door is closed, the door switch requires adjustment.

The same loading considerations apply to interior storage areas as to exterior. Even though your motor home has a lot of storage space, use good sense when loading. Consult the section on capacity and weighing.

## **INTERIOR AND FURNISHINGS**

The materials used inside your motor home have been selected for durability and comfort. With reasonable care, these materials will stand up under years of recreational living. The MAINTENANCE SECTION in this manual outlines care requirements for the various upholstery fabrics, floor, cabinet, and wall finishes.

### *Dinette Conversion*

To convert the dinette into a bed:

- \* Unfasten and remove cushions.
- \* Reach under the table, fold the leg up under the table top.
- \* Raise front portion of table several inches to disengage inserts from the wall supports.

- \* Lower table top to the dinette frame to complete bed base.
- \* Slide seat and back cushion into place over bed base.

### *Sofa/Lounge Conversion*

To convert a sofa/lounge into a bed:

- \* Remove sofa bolsters.
- \* Lift front of sofa frame up and out.
- \* Push the back of the lounge back and down.
- \* Push the seat belts through the space between the lounge back and seat.

To restore the sofa/lounge:

- \* Pull the seat belts back up through the space.
- \* Lift the front edge of the sofa frame up, and push it back. The sofa back will come up.
- \* Push the sofa into position.

**WARNING: NEVER RIDE IN A SEAT NOT FURNISHED WITH A SEAT BELT. ALWAYS USE SEAT BELTS WHILE TRAVELING.**

### *Interior Lighting*

Both decorative and "utility" style 12-volt lighting fixtures may be used in your motor home.

Utility style fixtures may be either single or dual. A slide switch selects either single or dual brightness. Clean the lenses in soapy water.

### *Overhead Vents*

Overhead vents located in the galley and bathroom areas help circulate fresh air through the motor home, and exhaust galley and bathroom odors and vapors from cooking and bathing.

Turn the crank in the center of the vent to open and adjust it. Some vents may also be equipped with a 12-volt fan. A switch controls fan operation. Be sure to turn the fan OFF before closing the vent.

If you travel in heavily wooded areas or other places where overhead clearance is restricted, close the vents or lower them so they don't strike overhead obstructions.

The vents may be cleaned from the top of the motor home. Use soapy water on the vent cover. The screens may be vacuumed or lightly brushed to remove accumulations of leaves or other debris.

Lubricate the gears and mechanism yearly with a light, water resistant grease.

## **EFFECTS OF PROLONGED OCCUPANCY**

Your motor home was designed primarily for recreational use and short term occupancy. If you expect to occupy the motor home for an extended period, be prepared to deal with condensation and the humid conditions that may be encountered. The relatively small volume, and tight, compact construction of a modern recreational vehicle mean that the normal living activities of even a few occupants will lead to rapid saturation of the air contained in the motor home and the appearance of visible moisture, especially in cold weather. If you know the signs of excessive moisture and condensation, you can minimize their effects.

Just as moisture collects on the outside of a glass of cold water during humid weather, moisture can condense on the inside surfaces of your motor home during use in cold weather when humidity of the interior air is high. This condition is much greater in a recreational vehicle than in most houses because the insulated walls of the vehicle are much thinner than house walls, and the small size and tight construction of the vehicle allow a quick buildup of high moisture levels in the inside air.

The air inside a recreational vehicle can contain a surprisingly large amount of water vapor. Estimates indicate that a family of four can vaporize up to three gallons of water daily through breathing, cooking, bathing, and washing. Unless this water vapor is carried outside by ventilation, or condensed by a dehumidifier, it will condense on the inside of the windows and walls as moisture, or in cold weather as frost or ice. It may also condense out of sight within the walls or the ceiling where it will manifest itself as stained panels. Appearance of these conditions indicates a condensation problem.

## **CONTROLLING MOISTURE CONDENSATION**

You can reduce or eliminate interior moisture condensation during cold weather by taking the following steps:

### **Ventilate with outside air.**

Partially open one or more roof vents and one or more windows to provide controlled circulation of outside air into the interior. While this ventilation will increase furnace heating load, it will greatly reduce, or eliminate, water condensation.

**Note: Even when it is raining or snowing, ventilation air from outside will be far drier than interior air and will effectively reduce condensation.**

**Install tight fitting storm windows to reduce or eliminate condensation on window glass.**

The interior surface of the storm window will be at least 20 degrees warmer, reducing moisture con-

densation. **DO NOT COVER THE EMERGENCY EXIT WINDOW.** This window must be left accessible at all times for emergency exit.

### **Reduce moisture released inside the motor home.**

Run the range vent fan when cooking and the bath vent fan (or open the bath vent) when bathing to carry water vapor out of the motor home. Avoid making steam from excessive boiling or use of hot water. Remove water or snow from shoes before entering to avoid soaking the carpet. Avoid drying overcoats or other clothes inside the motor home.

**WARNING: DO NOT HEAT THE MOTOR HOME INTERIOR WITH THE RANGE OR OVEN.** In addition to the hazards of toxic fumes and oxygen depletion which make heating by the range or oven very dangerous, open flames add moisture to the interior air, increasing condensation. Do not use an air humidifier inside the motor home. Water put into the air by the humidifier will increase condensation.

### **Ventilate closets and cabinets.**

During prolonged use in very cold weather, leave cabinet and closet doors partially open to warm and ventilate the interiors of storage compartments built against exterior walls. The air flow will warm the exterior wall surface, reducing or eliminating condensation and preventing possible ice formation.

### **Install a dehumidifier appliance.**

During prolonged, continuous use, a dehumidifying appliance may be more comfortable and effective in removing excess moisture from the interior air. While use of a dehumidifier is not a "cure-all", and ventilation, storm windows, and moisture reduction continue to be important, operation of the dehumidifier will reduce the amount of outside air needed for ventilation. Heating load on the furnace will be reduced, and the interior will be less drafty.

## **FIRE SAFETY**

The hazard and possibility of fire exists in all areas of life, and the recreational life-style is no exception. Your motor home is a complex machine made up of many materials -- some of them flammable. But like most hazards, the possibility of fire can be minimized, if not totally eliminated, by recognizing the danger and practicing common sense safety and maintenance habits.

Fires are generally caused by unattended food cooking on the stove or in the oven, faulty or damaged wiring and electrical devices, fuel leaks (both gasoline and LPG), or carelessness. Under the right circumstances, almost anything can be destroyed by fire. The fire extinguisher furnished with your motor home is rated for Class B (gasoline, grease, flammable liquids) and Class C (electrical) fires since these are

the most common types of fires in vehicles. Read the instructions on the fire extinguisher. Know how and when to use it.

Consider these fire safety suggestions:

- \* Before refueling your motor home or any generator fuel tank that may be installed on or in your motor home, be sure to turn off all pilot flames and appliances in your motor home. Explosive fuel clouds may be present at fuel filling stations.
- \* If you experience a fire while traveling, **MAINTAIN CONTROL OF THE VEHICLE UNTIL YOU CAN SAFELY STOP IT. EVACUATE THE VEHICLE AS QUICKLY AND SAFELY AS POSSIBLE.**
- \* If you experience a fire while camped, **EVACUATE THE VEHICLE AS QUICKLY AND SAFELY AS POSSIBLE.**
- \* Consider the cause and severity of the fire and the risk involved before trying to put it out. If the fire is major or is fuel-fed, stand clear of the vehicle and wait for the fire department or other emergency assistance.
- \* If your motor home is damaged by fire, do not drive it or live in it until you have thoroughly examined it, found the cause of the fire, and fixed it.

## ***Smoke Detector***

A smoke detector is furnished with your motor home as a warning device. See "APPLIANCES" section. Instructions for its operation and testing are included in your Owner's Information Package. Read these instructions and follow the test procedures outlined.

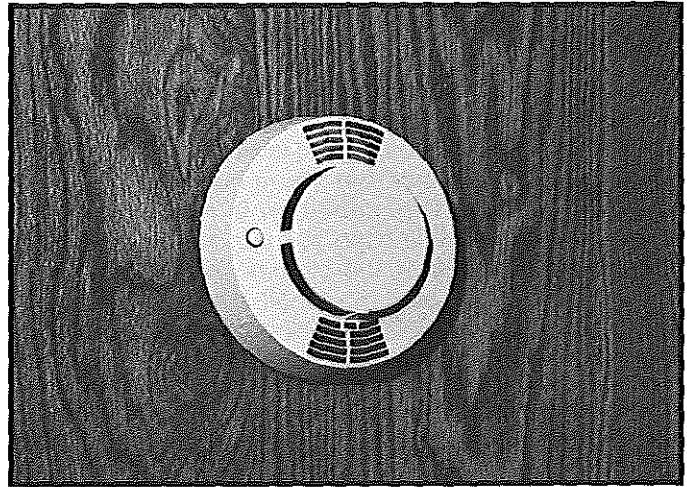

*Smoke Detector*

# PLUMBING SYSTEMS

The plumbing systems in your motor home are constructed of thermoplastic materials. Holding tanks and piping components are strong, lightweight, and corrosion resistant.

## FRESH WATER SYSTEM

Fresh water is available from either an external "city water" hookup or onboard storage.

The external system is pressurized by the water system at an RV park or city water supply. When you use this system, the onboard pump is isolated from the city water pressure by a check valve.

Connect the city water system as follows:

- \* Remove the protective cap over the city water inlet.

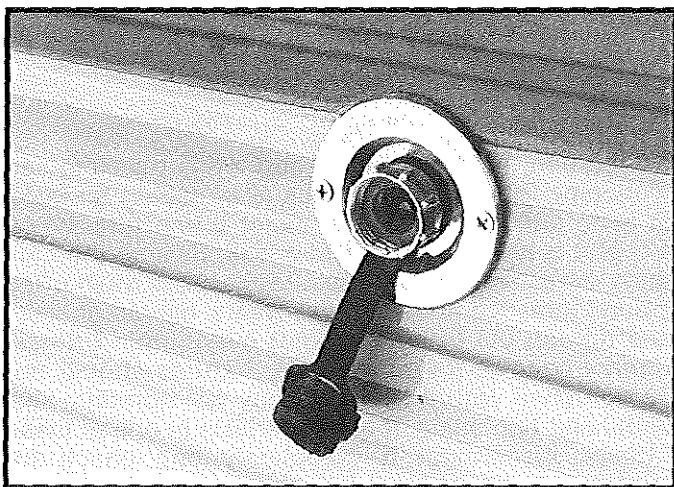

Tank Fill

- \* Connect one end of a potable water hose to park or city water supply. This will usually be a faucet or valve similar to your garden hose valve at home. "Potable water" hoses are available at RV supply stores.
- \* Run the city water supply for a few seconds to clear the line.
- \* Turn the supply OFF.
- \* Connect the hose to the inlet fitting.
- \* Turn the supply ON. Open all faucets and clear the lines. Close faucets.

Disconnect the city water as follows:

**CAUTION: OVERFILLING THE FRESH WATER TANK FROM A PRESSURIZED SOURCE MAY CAUSE SERIOUS DAMAGE TO THE WATER TANK OR STRUCTURAL COMPONENTS. MONITOR WATER TANK FILLING CONTINUALLY.**

- \* Close the park or city water supply valve.
- \* Remove the hose from the city water supply valve.
- \* Disconnect the hose from the inlet, coil and store it, and replace the inlet protective cap.

The onboard water storage tank is filled through a special filler cap outside the motor home. To fill the fresh water tank, open the spout, remove the vent plug and fill the tank with the hose. After filling the tank, close the spout, and replace the vent plug.

Avoid leaving water in the tank when the motor home is not in use. Turn the water pump OFF before draining the water tank. Whenever possible, drain the fresh water tank before traveling. Water in the tank will reduce the carrying capacity of the motor home. See "WEIGHING AND LOADING" section.

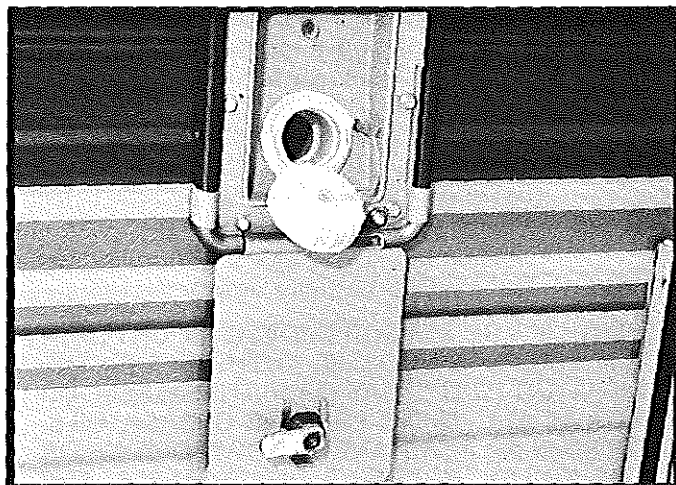

City Water Connection

## The Water Pump

The onboard fresh water system is pressurized by a self-priming, 12-volt DC pump. The pump operates automatically when the pump power switch is ON and faucet or valve is opened. When the faucet or valve is closed, the pump shuts off. A built-in check valve prevents back flow and protects the pump and fresh water tank from excessive city water system pressures up to 200 psi. The pump stroke will overcome air trapped in the lines thus preventing air lock. At free flow, the pump draws approximately 7 to 7-1/2 amps, and can run dry for extended periods without damage. A 10-amp fuse at the converter panel protects the pump circuit. See ELECTRICAL SYSTEM.

Turn the pump master switch ON to pressurize the system. When a faucet is opened after the initial filling of the tank, the water may sputter for a few seconds. This is normal and is not cause for concern. The water flow will become steady when all air is bled from the water lines.

## **The Monitor Panel**

The monitor panel allows you to conveniently check the approximate levels in the fresh water tank and the holding tanks. Electrical probes installed in the tanks measure the levels at various points in the tanks.

To check tank levels:

- \* Press "WATER" or "HOLDING TANK 1" or "2" rocker switches. HOLDING TANK 1 is the black water (toilet waste) tank, and HOLDING TANK 2 is gray water (sink and shower wastes).
- \* The "E" or empty indicator light will always be lit when the rocker switches are depressed. If the tank is full, all lights will be on. Lights are sequential, and indicate level in approximately 1/4 tank increments. If the tank selected is approximately 1/2-full, for example, lights "E", "1/4", and "1/2" will be on.
- \* Erroneous indications can be caused by:
  - a. Water with low mineral content. Level is measured by a very low level electrical signal traveling through the liquid. Some water, very low in mineral content used in the fresh water tank, may not conduct the signal properly. This condition may be infrequent, but can exist. Check the panel reading when the fresh water tank is filled.
  - b. Material trapped on the sides of the holding tanks may give a full reading when the tank is actually empty.

**NOTE: IF THE SENSOR PROBES MOUNTED IN THE TANKS GET COATED WITH GREASE, THE MONITOR PANEL MAY INDICATE FALSELY OR NOT AT ALL. AVOID POURING GREASE, OILS, OR SIMILAR SUBSTANCES DOWN DRAINS OR THE TOILET. IF THIS IS UNAVOIDABLE, THE HOLDING TANK(S) SHOULD BE WASHED OUT WITH A SOAPY WATER SOLUTION.**

## **Sanitizing The Fresh Water System**

Sanitize the fresh water tank and piping at least once a year, and whenever the motor home sits for a prolonged period. This will help keep the tank and lines fresh, and will discourage the growth of bacteria and other organisms that can contaminate the water supply. Use a chlorine/fresh water rinse as follows:

1. Prepare a solution of 1/4-cup household liquid chlorine bleach (5% sodium hypochlorite) to one gallon of water for each 15 gallons of tank capacity.
2. Close drain valves and faucets, pour chlorine solution into the fresh water tank filler spout, and complete filling with fresh water.
3. Turn water pump switch ON. (Be sure you have 12-volt DC power.) Open all faucets individually until water flows steadily, then turn off. This will purge any air from the lines.

4. Top off water tank with fresh water and wait three hours.
5. Drain the entire system by opening all fresh water tank valves, faucets, and plumbing line drain valves.
6. Flush the system with drinking quality water. Let the fresh water flow through the system for several minutes to flush out the chlorine solution.
7. After you stop the flushing, close the faucets, and drain valves. You can now fill the tank with fresh water, and the system is ready to use.

## **Troubleshooting The Fresh Water System**

Water system problems usually fall into two categories: inherent system problems, and problems caused by neglect. System problems are usually the result of road vibration, and campsite water pressure variations. Problems of neglect usually stem from failure to clean filters, improper winterization, and poor battery maintenance. Most water system problems can be avoided by conscientious maintenance.

### **Leaks**

Vibration, flexing and twisting while traveling can work pipe fittings loose. Check all plumbing for leaks at least once a year. If the water pump runs when a faucet is not open, suspect a leak. Be sure the tank drain valves are tightly closed. Leaks occur most often around threaded fittings. If necessary, tighten or clean and tighten the fittings. Do not overtighten fittings. Connections at galley and lavatory fixtures should not be tightened with a wrench. They will normally seal with hand-tightening. If a leak persists at one of these fittings, disconnect it completely and check for mineral deposits or other foreign matter at the seating surfaces. Clean the surfaces thoroughly and reinstall the fitting.

Connections at the water tank, pump and valves are made with special clamps. They can be replaced with standard aircraft type hose clamps.

Leaks caused by freezing damage can be prevented by proper winterization of the system. See WINTERIZATION section of this manual. Freezing damage is usually extensive and may include a burst water tank, split piping, and a damaged water pump, toilet, and water heater. If you experience this type of damage, repairs can best be made by an authorized Fleetwood RV Service Center.

### **Clogged Water Filter**

Dirt, mineral scale, or organic matter are filtered out of the fresh water system by an inline water filter on the inlet side of the water pump. If you suspect a clogged filter, it is easily removed and cleaned.

Inspect the filter after the first 90 days of use, clean it if necessary, and inspect annually thereafter.

- \* Unscrew the fitting at the inlet end of the filter.
- \* Pull the water line off the filter.
- \* Unscrew the filter from the water pump.
- \* Turn each end of the filter and pull apart.
- \* Flush out and clean screen.
- \* Reverse procedure to install.
- \* Operate the water pump and check for leaks.

### **Excessive Water Pressure**

Some campground water systems may operate at pressures that can damage the water system in your motor home or cause water pump failure. Your RV supply dealer can advise you on the best choice regarding water pressure regulators.

### **Water Pump Troubleshooting**

The water pump in your motor home is a durable device that will operate for years with little attention. Most water pump problems can be solved by a common-sense approach. The following is a discussion of possible trouble spots and what to do.

#### **Pump motor does not operate**

- \* Your motor home has two water pump switches — one MASTER switch and one in the pressure sensing assembly in the pump head. Be sure the "WATER PUMP" master switch is on. Even though the pump operates automatically when a faucet is opened, the pump master switch has to be on for that to happen.
- \* Check battery condition if the 12V converter is not operating. If the battery is discharged, the pump won't run.
- \* Check the fuse. The water pump fuse is located on the electrical converter panel. If it is blown, there is a reason for it. Check the pump wiring for shorts. Do not replace the pump fuse with a fuse rated for more than 10 amps.
- \* Check for disconnected or corroded wires or terminals. Clean and reconnect if necessary.
- \* In cold weather, check for pump freeze up. If water is frozen in the pump, thaw it by placing a lighted bulb near the pump head. **DO NOT USE A TORCH OR OTHER OPEN FLAME.**

#### **Pump motor runs but no water flows**

- \* Be sure there is water in the fresh water tank. Check level at the monitor panel. See MONITOR PANEL.
- \* Check the filter. If it is clogged, remove it, flush out and clean screen as a temporary fix. If that doesn't work, it must be replaced.

- \* Check inlet and outlet hoses and fittings. Look for kinked or collapsed hoses, or loose clamps that could be letting air into the system. Avoid storing anything in the water pump area. A heavy item could flatten a hose or damage the inlet or outlet hoses and fittings.

#### **Pump runs but water sputters**

- \* This is normal after an initial filling of the fresh water tank and lines. It should stop after a few seconds.
- \* If sputtering continues, the water tank may be almost empty. Add water if necessary.
- \* If sputtering continues, check for air leaks in the inlet side of the pump.

#### **Pump cycles on and off when all faucets are closed**

- \* Check for leaks in the water lines.
- \* Be sure tank drain valves are tightly closed.
- \* The pump may have an internal leak. Refer pump repairs to an authorized Fleetwood RV Service Center.

#### **Pump does not shut off**

- \* Water tank may be empty.
- \* Check battery condition. A low battery will allow the pump to run but not develop enough pressure to shut off.
- \* The pump switch mechanism may be stuck. Gently tap the switch cap on the end of the pump with a screwdriver handle.
- \* If the switch mechanism needs replacing, refer repairs to an authorized Fleetwood RV Service Center.

#### **Pump head leaks**

- \* Tighten screws in the pump head assembly. **DO NOT OVERTIGHTEN.**
- \* The head may be cracked. This can be caused by stress failure, but is more likely caused by water freezing in the pump head. Refer repairs to an authorized Fleetwood RV Service Center.

#### **Pump does not prime**

- \* Water tank may be empty.
- \* Filter may be clogged.
- \* Inlet hoses may be kinked or collapsed.
- \* Failure to prime may be caused by internal pump valve failure or foreign material lodged in a valve seat. These conditions require pump disassembly. Refer these repairs to an authorized Fleetwood RV Service Center.

### **THE WASTE WATER SYSTEM**

The waste water system in your motor home is made up of sinks, tub, shower, toilet, plumbing drain

and vent lines, a "gray water" holding tank, and a "black water" holding tank. The holding tanks make the system completely self-contained and allow you to dispose of waste water at your convenience. A flexible sewer hose is required to connect the holding tank outlet to the inlet of an approved waste water dump station or sewer system.

The drain plumbing is very similar to that used in your home. The system is trapped and vented to prevent waste gases from backing up into the motor home. The drain plumbing is made of ABS plastic, and is durable and resistant to most chemicals.

### **Toilet**

Your motor home is equipped with a marine-type toilet.

To operate the Aqua Magic IV:

- \* To flush, pull the black lever located on the right side of the toilet forward until rinse clears the bowl, then release the lever slowly.
- \* The water fill lever (white lever) can be operated independently of the flush to adjust the level of water in the bowl.

To operate the SL model:

- \* Depress the small pedal to add water to the bowl to desired level. Release pedal slowly.
- \* To flush, depress large pedal until rinse clears the bowl. Release pedal slowly.

If your motor home is equipped with a toilet other than these models, please follow the operating instructions found in your Owner's Information Package.

### **Toilet Maintenance**

The toilet does not require any routine maintenance. Clean the unit with a high grade, non-abrasive cleaner. DO NOT use highly concentrated or high acid household or toilet bowl cleaners. These products can damage the finish and valve components in the flush seal.

The Aqua Magic IV has a removable seat to facilitate cleaning. To remove seat:

- \* Open both seat and cover.
- \* Grasp assembly on both sides and pull up and away from you at approximately 45 degrees.
- \* To reinstall, place legs of assembly in rear slots of cover until you feel the engagement.

### **Toilet Troubleshooting**

*Water keeps running into the bowl*

On SL models, clean out foreign material in the groove where the valve blade seats in the bottom of the bowl. Use a bent coathanger, or screwdriver to scrape the groove. Do not damage the blade seal.

On Aqua Magic IV models, be sure the levers return all the way. If they don't, there may be foreign matter on the waste blade valve or seal in the bottom of the bowl.

*Toilet leaks, water on floor*

Check water inlet connection. Tighten, or clean and tighten if necessary.

Refer other toilet leaking conditions to an authorized Fleetwood RV Service Center.

*Foot pedal hard to operate or blade sticks (SL models only)*

Spray light film of silicone on blade.

*Poor Flush*

The levers (AM IV) or pedal (SL) must be held fully open during the flush. Two to three seconds is required for a good flush.

Be sure there is enough water in the bowl to carry waste into the holding tank.

### **Dumping The Holding Tanks**

The holding tanks terminate in a valve arrangement that permits dumping each tank separately or together. The valves are called "knife valves". A blade closes the opening in the sewer drain pipes. The blade is connected to a T-handle that is pulled to release the contents of the tank(s). During self-containment use, the sewer line is securely capped to prevent leakage of waste material onto the ground or pavement. DO NOT PULL THE HOLDING TANK KNIFE VALVE OPEN WHEN THE PROTECTIVE CAP IS INSTALLED ON THE PIPE. Always ensure that the tank is evacuated into an acceptable sewer inlet or dump station.

**WARNING: HOLDING TANKS ARE ENCLOSED SEWER SYSTEMS AND AS SUCH MUST BE DRAINED INTO AN APPROVED DUMP STATION. BOTH TOILET AND GRAY WATER HOLDING TANKS MUST BE DRAINED AND THOROUGHLY RINSED REGULARLY TO PREVENT ACCUMULATION OF HARMFUL OR TOXIC MATERIALS.**

Whenever possible, dump the holding tanks before traveling. Waste water and sewage in the holding tanks reduce the carrying capacity of the motor home. See "WEIGHING AND LOADING" section.

Dump the holding tanks only when they are at least 3/4 full. If necessary, fill the tanks with water to 3/4 full. This provides sufficient water to ensure complete flushing of waste material into the sewer line.

During extended or semi-permanent hookups to sewage disposal systems, waste material could build up in the tank and cause serious plugging if the tank valves are continuously open. In these cases, keep the valves closed until the tanks are 3/4 full, and then drain into the sewage system.

The holding tank drain valve outlet is set up to be used with a removable termination fitting that locks onto the outlet with a clockwise twist. The sewer drain hose is clamped to this fitting, and is always ready when you need to drain the holding tanks. When you are operating self-contained, or you store the motor home, a protective cap is installed in place of the termination fitting.

**NOTE: LOCAL OR STATE REGULATIONS MAY PROHIBIT HIGHWAY TRAVEL UNLESS THE HOLDING TANK OUTLET IS SECURELY CAPPED.**

When you want to drain the holding tanks:

- \* Attach the sewer hose to holding tank outlet. Insert the end of the hose into the sewer or dump station inlet, pushing it firmly far enough into the opening to be secure. In some cases, adapters may be necessary between the line and the inlet. Arrange the sewer hose so it slopes evenly.

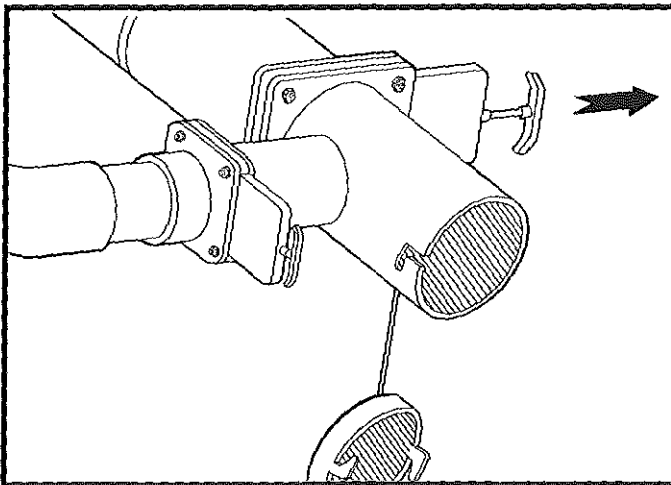

*Black Water Tank Dumping*

- \* Dump the black water holding tank first. Grasp the handle of the black water knife valve (the large one) firmly and slide the valve open with a quick, steady pull.
- \* Allow enough time for the tank to drain completely. Rinse and flush the tank through the toilet. When the tank is empty, push the handle in to close the valve. Reset the locking device. Even if you are parked at a site with a semipermanent sewer hookup, keep the black water knife valve closed to allow the waste to build up. The outlet will probably clog if you leave the knife valve open continually. Run enough water into the tank to cover the bottom. This will aid the break up of solid wastes.
- \* To dump the gray water tank, repeat the steps above for the small knife valve. This tank is dumped last to aid in flushing the outlets and hose. The gray water knife valve may be left open in a semipermanent hookup.

- \* Remove the sewer hose, cap the outlet, and store the hose.
- \* Rinse out the sewer hose with fresh water and remove the sewer hose from the dump station.
- \* Replace sewer or dump station covers.

PLEASE . . . PRACTICE GOOD HOUSEKEEPING WHEN DRAINING WASTES AT A CAMPSITE OR DISPOSAL STATION. LEAVE THE SITE IN GOOD ORDER. ABOVE ALL, DO NOT POLLUTE.

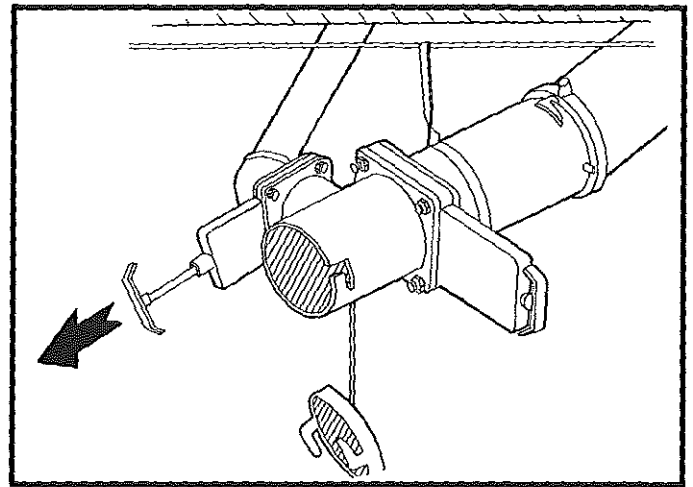

*Grey Holding Tank Dumping*

### ***Holding Tank Care and Maintenance***

Since holding tanks don't rely on any sophisticated mechanical devices for their operation, they are virtually troublefree. The most common problem is also an unpleasant one — clogging. You can minimize the chances of clogging by keeping the following considerations in mind;

- \* Keep the black water tank knife valve closed. Fill tank to at least 3/4 full before dumping. Be sure to cover the tank bottom with water after dumping.
- \* Use only toilet tissue formulated for use in septic tank or RV sanitation systems.
- \* Keep both knife valves closed and locked, and the drain cap tightly in place when using the system on the road.
- \* Use only cleaners that are approved for use in septic tank or RV sanitation systems.
- \* Use a special holding tank deodorant chemical approved for septic tank systems in the black water holding tank. These chemicals aid the breakdown of solid wastes, and make the system much more pleasant to use.
- \* Do not put facial tissue, paper, ethylene glycol-based or other automotive antifreeze, sanitary napkins, or household toilet cleaners in the holding tanks.
- \* Do not put anything solid in either tank that could scratch or puncture the tank.

If the drain system does get clogged:

- \* Use a hand-operated probe to loosen stubborn accumulations. Seriously clogged P-traps may require disassembly. Be careful not to over-tighten when reassembling.
- \* Do not use harsh household drain cleaners.
- \* Do not use motorized drain augers.
- \* Sometimes the holding tank valve will get clogged. In this case, a hand-operated auger may be necessary. Be ready to close the valve quickly once the clog is cleared. If the seal gets damaged, it is easily replaced.

### ***WATER SYSTEM WINTERIZING***

Read this section completely before performing winterization.

If the motor home is to be stored unheated in temperatures below freezing, the fresh water and waste systems should be winterized. A detailed storage and winterization procedure is outlined in the

**"PREPARING THE MOTOR HOME FOR LONG TERM STORAGE"** section.

**CAUTION: DRAINING THE WATER SYSTEM ALONE WILL NOT PROVIDE ADEQUATE COLD WEATHER PROTECTION. IF THE MOTOR HOME IS TO BE UNHEATED DURING FREEZING TEMPERATURES, CONSULT YOUR DEALER FOR THE BEST WINTERIZING PROCEDURE FOR YOUR CLIMATE. YOUR DEALER CAN WINTERIZE YOUR MOTOR HOME FOR YOU OR CAN SUPPLY YOU WITH ONE OF THE SPECIAL ANTI-FREEZES WHICH ARE SAFE AND APPROVED FOR USE IN RV WATER SYSTEMS. FOLLOW THE INSTRUCTIONS FURNISHED WITH THE ANTIFREEZE.**

**WARNING: DO NOT USE AUTOMOTIVE OR WINDSHIELD WASHER ANTIFREEZE IN THE MOTOR HOME WATER SYSTEM. THESE COULD BE HARMFUL IF SWALLOWED.**

If the motor home is to be stored during freezing temperatures, see **"PREPARING THE MOTOR HOME FOR LONG TERM STORAGE"** section of this manual.

# ELECTRICAL SYSTEMS

The electrical systems in your motor home are designed and built in accordance with all regulations, codes, and standards in effect at the time the motor home was built.

## CHASSIS ELECTRICAL SYSTEM

This is the vehicle electrical system. It includes the vehicle battery, charging system, ignition system, cockpit controls and instruments, cockpit heater/air conditioner, and the headlights, taillights, turn signals, and other vehicle lights and accessories.

### Chassis Bulbs & Fuses

Replace bulbs with equivalent types as marked on the bulb.

Fuses for the chassis electrical system are located under the left instrument panel. Others may be found in the 12-volt power leads of the related equipment and accessories.

## 12-VOLT COACH SYSTEM

All 12-volt lighting fixtures and convenience outlets, 12-volt powered vents, fans, motors, and 12-volt accessories are included in this system. The fresh water pump and any 12-volt entertainment equipment are connected to this system. The 12-volt power source is a special deep cycle 12-volt lead-acid storage battery. Twelve volt power is also provided by an AC/DC converter. These batteries are charged by the motor home engine alternator, or by the charging circuit included in the converter.

The converter is the nerve center of the 12-volt DC (as well as the 120-volt AC system.) Fuses for the 12-volt DC circuits are located at the converter panel. Always replace fuses with the same type and amperage rating.

**WARNING: DO NOT INSTALL 12-VOLT FUSES WITH AMPERAGE RATINGS GREATER THAN THAT SPECIFIED ON FUSEBOX.**

### Auxiliary Battery

The auxiliary battery is the primary source for normal living-area needs. Sensing and switching circuits permit the vehicle alternator to charge all batteries as required and prevent the living area 12-volt requirements from depleting the vehicle battery.

**NOTE: All living area radios and tape decks draw from the auxiliary battery, and extended usage may discharge it.**

Battery condition can be checked on the Monitor Panel. To check the battery charge:

1. Unplug the 120-volt AC power cord to turn the power converter off.

2. Press "BATTERY" rocker switch on the panel.
3. Turn on a light or any 12-volt appliance. The battery must be checked with a load.
4. Read battery condition on the meter. Red is poor, yellow is fair, and green is good.

### Battery Inspection and Care

**WARNING: DISCONNECT THE 120-VOLT ELECTRIC CORD AND THE POSITIVE TERMINAL FROM THE MOTOR HOME BATTERY BEFORE WORKING ON EITHER ELECTRICAL SYSTEM.**

**WARNING: REMOVE RINGS, METAL WATCH-BANDS, AND OTHER METAL JEWELRY BEFORE WORKING AROUND A BATTERY. USE CAUTION WHEN USING METAL TOOLS. IF THE TOOL CONTACTS THE POSITIVE BATTERY TERMINAL OR METAL CONNECTED TO IT, A SHORT CIRCUIT COULD OCCUR WHICH COULD CAUSE PERSONAL INJURY OR FIRE.**

**WARNING: DO NOT ALLOW BATTERY ELECTROLYTE TO CONTACT SKIN, EYES, FABRICS, OR PAINTED SURFACES. THE ELECTROLYTE IS A SULFURIC ACID SOLUTION WHICH COULD CAUSE SERIOUS PERSONAL INJURY OR PROPERTY DAMAGE. WEAR EYE PROTECTION WHEN WORKING WITH BATTERIES.**

Check the external condition of the battery periodically. Look for cracks in the cover and case. Check the vent plugs. Replace them if they are cracked or broken. Keep the battery clean. Accumulations of acid film and dirt may permit current to flow between the terminals and discharge the battery. To clean the battery, wash it with a diluted solution of baking soda and water to neutralize any acid present, then flush with clean water. Acid foaming around terminals or on top of the battery is normal acid neutralization. Avoid getting the soda solution in the battery. Be sure the vent caps are tight. Dry the cables and terminals. Don't use grease on the bare metal inside the cable terminals to prevent corrosion. Grease is an insulator. Electricity will not flow through it. A plastic ignition spray will protect the terminals after you have cleaned and reinstalled them.

Check the battery often. Keep the carrier and hold-down hardware clean and free of corrosion and chemical accumulation.

### Battery Charging

Normally the battery will be kept charged by either the motor home charging system while on the road, or by the AC/DC power converter when plugged into AC service. On those occasions when the battery needs to be charged from a different charging source, please follow these safety guidelines:

**WARNING: NEVER EXPOSE THE BATTERY TO OPEN FLAME OR ELECTRIC SPARK. CHEMICAL ACTION IN THE BATTERY GENERATES HYDROGEN GAS WHICH IS FLAMMABLE AND EXPLOSIVE. DO NOT ALLOW BATTERY ELECTROLYTE TO CONTACT SKIN, EYES, FABRICS, OR PAINTED SURFACES.**

- \* Do not smoke near batteries being charged or which have been recently charged. Please note that batteries are being charged while you drive, and while you are connected to 110-volt AC power through the converter/charger circuit.
- \* Do not break live circuits at the terminals of the battery. Use care when connecting or disconnecting booster leads or cables on fast chargers. Poor connections are a common cause of electrical arcs which can cause explosions.
- \* Check and adjust the electrolyte level before charging. Fill each cell to the indicator with distilled water.
- \* Do not charge the battery at a rate that causes the electrolyte to spew out the vent caps. Always remove vent caps before charging the battery.

### **Selecting a Replacement Battery**

When the battery requires replacement, always choose a battery with the same physical and electrical characteristics as the original equipment. Do not use a regular automotive battery to replace the auxiliary battery. Your dealer or an authorized Fleetwood Service Center can advise you on proper battery selection.

### **120-VOLT AC SYSTEM**

This system provides grounded electrical service for appliances such as air conditioners, TV, microwave ovens, etc. The 120-volt system also provides a power source for the converter. Your motor home is equipped with a heavy duty power cord to connect to an external 120-volt, 30 amp AC service. The cord and connector are molded together to form a weather-proof cable assembly. Do not cut or alter the cable in any way. Do not remove the ground pin in the cable connector, or defeat the ground circuit in the motor home. If you have to use adapters to plug into an electrical service, be sure the ground is maintained.

**WARNING: DO NOT OPERATE THE 120-VOLT ELECTRICAL SYSTEM WITHOUT A PROPER GROUND.**

### **The Power Converter**

The converter will supply 12-volt requirements when your motor home is operating on 120 AC volts. Thus you will not have to worry about running the battery down. When you are plugged into 120-volt AC service, the converter automatically switches the

load from the battery to the converter. The onboard battery will gradually be brought up to a full charge and maintained by the battery charger as long as 120-volt power is available.

Maximum battery charge rate is 10 amps. Note that because the converter uses a special sensing circuit connected to the battery which draws a very small amount of current, the battery may become discharged if the motor home is not used for an extended period of time, or if the converter is not connected to a 120-volt AC source. Some accessories or equipment such as clocks, radios, or the refrigerator may draw small amounts of current even when turned "OFF". The following chart specifies current draw for these devices.

	Temporary Storage	Turned Off
Radio memory (electronic tuning)	.25	.25
LP leak detector	.80	0.
Water heater (auto ignition)	3.0	0.
Total current draw in amps	4.05	.25

If the motor home is to be unused for longer than 10 days, disconnect the battery.

If the power converter malfunctions or requires service, refer repairs to an authorized Fleetwood Service Center.

### **GROUND FAULT INTERRUPTER**

Bathroom and patio 120V electrical outlets are protected by a Ground Fault Interrupter (GFI). This device is provided in compliance with ANSI A119.2/NFPA 501C requirements, and is intended to protect you against the hazards of line to ground electric faults and electrical leakage shocks possible when using electrical appliances in the bathroom or damp areas. The materials used to insulate these appliances and devices can deteriorate over time or develop cracks or weak spots that could allow electric current to "leak" through the insulation. Should a circuit or appliance (electric shaver, hair dryer, etc.) develop a potential shock hazard of this type, the GFI device is designed to disconnect the outlet (and other outlets on the same circuit), limiting your exposure time to the shock hazard caused by current leakage to ground.

**The GFI device does not prevent electric shock, nor does it protect a person who comes into contact with both "hot" and neutral sides of the circuit. It does not protect against electrical circuit overloads.**

Test the GFI at least once a month while operating on 120 volts AC. To test the GFI:

- \* Push the "TEST" button. The "RESET" button should pop out, indicating that the protected circuit has been disconnected.
- \* **IF THE "RESET" BUTTON DOES NOT POP OUT WHEN THE TEST BUTTON IS PUSHED, A LOSS OF GROUND FAULT PROTECTION IS INDICATED. DO NOT USE THE OUTLET OR**

**OTHER OUTLETS ON THE SAME CIRCUIT. HAVE THE MOTOR HOME ELECTRICAL SYSTEM CHECKED AT AN AUTHORIZED FLEETWOOD SERVICE CENTER OR BY A QUALIFIED ELECTRICIAN. DO NOT USE THE SYSTEM UNTIL THE PROBLEM HAS BEEN CORRECTED.**

\* To restore power push the "RESET" button.

Your Owner's Information Package contains a card that can be used to record test dates. Keep the card in a conspicuous place, and keep it up to date.

**NOTE: If the patio outlet doesn't work, check the GFI. Reset it if necessary. If the GFI continues to trip, have the motor home electrical system checked at an authorized Fleetwood Service Center or by a qualified electrician.**

### **ENTERTAINMENT EQUIPMENT**

Instructional material for the optional entertainment system is included in your Owner's Information Package.

If additional entertainment equipment requiring 12-volt DC power is installed in the motor home, obtain the 12-volt DC source from the Fused Battery Circuit at the power converter. If you install entertainment equipment requiring 12 volts DC, be sure to install a choke filter with an amperage rating matched to the current requirements of the equipment.

### **TV ANTENNA**

The roof-mounted antenna is designed for reception of VHF and UHF television signals.

Operating and maintenance instructions are included in your Owner's Information Package.

When getting ready to travel, remember to lower the antenna and secure it to prevent damage to the antenna, motor home roof, or objects in the path of the antenna, such as overhead wires. **DO NOT TRAVEL WITH THE ANTENNA RAISED.**

**NOTE: The antenna booster power supply must be turned off to prevent battery drain. A red indicator light will glow when the unit is on.**

### **TV "GHOSTS" AND FM "FLUTTER"**

The television and radio systems in your motor home have been chosen to provide good performance under many varied signal conditions. Occasionally, though, you may experience "ghosts" on TV, or "flutter" when listening to FM broadcasts. In many cases, multipath distortion is responsible for these phenomena.

Both television and FM signals are broadcast at very high frequencies — from 50 million cycles per second up to the microwave region. These signals are easily reflected by buildings, hills, towers, aircraft, and even other vehicles. Consequently, at any location, a TV or FM signal could be occurring at your antenna from

not only the broadcast tower, but also via several different reflected paths. In some cases, a reflected signal could be an advantage — you may be situated in the shadow of a hill or mountain and the only signal you can receive is a reflected one.

Television and FM signals are exceedingly complex. When mixed with reflections of themselves, their complexity increases even more. Phase cancellations and beat-frequency components add up to cause the interference associated with multipath distortion. This type of distortion is compounded by the fact that your vehicle may be moving, causing an infinite series of direct and reflected signals. The fault is normally not with your receiver, although receivers with inadequate multipath compensation circuitry may compound the problem. Neither is your antenna system usually at fault. The idea that antennas, whether amplified or unamplified, "pull in" a signal is a popular misconception. An antenna does not pull a signal out of the air by virtue of its "power". The antenna only responds to signals present at the antenna elements. A good antenna design can improve the rejection of multipath signals.

Since distance from the broadcast tower is critical to reception clarity, remember that TV and FM signals have a range of only about 75 miles under the best of atmospheric and geographic conditions. The good reception you get at parks located at great distances from broadcast facilities is probably the result of satellite, microwave or other cable distribution systems. The antenna on your RV is no competition for these very expensive installations. The very best RV antenna systems compromise performance and efficiency for light weight and compactness. The amplifiers used in these systems attempt to overcome these compromises by presenting a reasonably good signal to the TV or FM radio terminals. But these antennas have a usable range of only about 50 miles under the best of conditions. Beyond that distance, or in marginal conditions, antenna performance falls off rapidly. In that case, the amplifier only amplifies the noise, or "snow" being picked up by the antenna elements.

### **Minimizing Multipath Distortion and Improving Signal Quality**

There is obviously very little that you can do about geography while you travel — except enjoy it. But if multipath distortion becomes a nuisance, try these tips:

- \* Re-orient the receiving antenna. Sometimes turning the antenna will pick up the stronger of either the direct or reflected signal. Try turning or rotating the antenna throughout its range. You may find your signal in a very unexpected direction.
- \* With FM stereo signals, switch the unit to MONO, if possible. Some of the phase and noise components of a stereo signal will disappear in MONO mode.

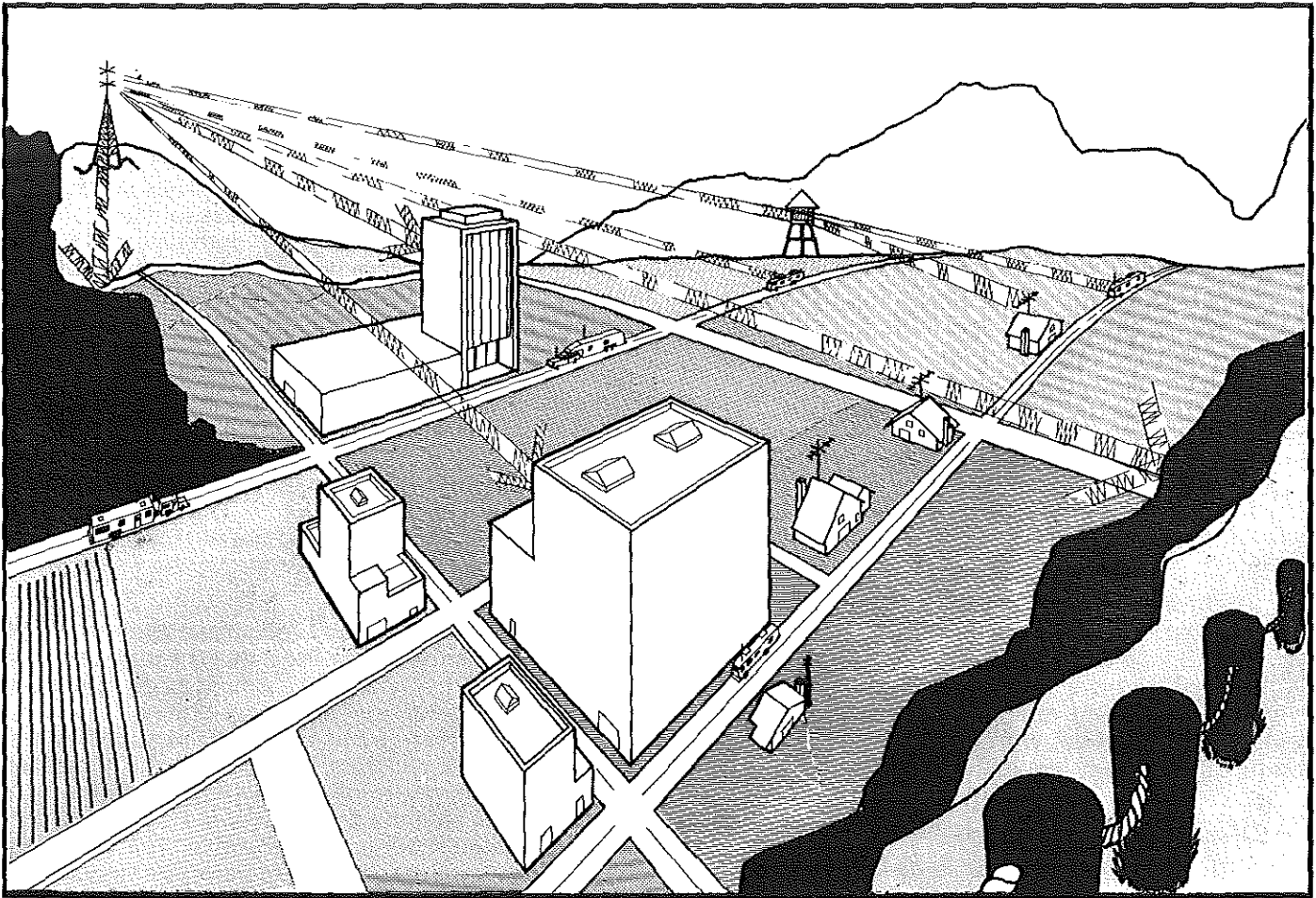

\* Reduce the treble setting to reduce background noise. Although not yielding the best high frequency performance, at least you may be able to reduce the irritation of the distortion.

### **GENERATOR POWER PLANT**

Your motor home may be equipped with a gasoline-powered generator which will provide complete electrical self-containment when regular public utility AC power is unavailable. Controls are at the generator and at a remote control panel located inside the motor home.

**NOTE:** Generator output may be connected to a 30-amp in-line fuse.

With the generator power plant operating, power is available at all of the 120-volt power outlets in the motor home, just as if the cord were connected to an external source.

### **GENERATOR FUEL SUPPLY**

For Ford Chassis: A special pick up tube in the fuel tank (set at approximately 1/4-tank level) allows generator operation without fear of running the fuel tank dry. At the 1/4-tank level, fuel to the generator will be unavailable, but the motor home engine can be operated.

For Chevrolet Chassis: The generator can run the fuel

tank dry if it is operated while the motor home engine is running. If the motor home is not running, the generator will run until the tank is at approximately the 1/4-tank level.

**NOTE:** Refer to your Generator Power Plant Manufacturer's Instruction Manual (provided in your Owner's Information Package) for service information before starting the generator. Do not start unit with a heavy power load. Always wait at least three minutes after starting generator before turning on (or plugging in) heavy electrical loads, such as the roof air conditioner.

### **GENERATOR OPERATION**

To start the generator, hold the switch in the START position until the unit starts, then release the switch. If the unit is slow to start, DO NOT hold the switch in the START position for more than 10 seconds. Release the switch, wait 15 seconds, then repeat. This will help avoid overheating and damaging the generator starting system. If this system fails to start the generator, manual starting instructions are discussed in the generator power plant manufacturer's instructions. To stop the unit, hold switch to the STOP position until the engine stops. Be sure to hold it until the engine stops. If you release the switch too soon, the engine will continue to run.

## **Generator Operating Safety Precautions**

- \* Read and understand the generator operating, maintenance and safety instructions furnished in your Owner's Information Package.
- \* Do not smoke or use an open flame near the generator unit or fuel tank.

**WARNING: DO NOT BLOCK THE GENERATOR VENTILATING AIR INLETS OR OUTLETS. THE AIR-COOLED ENGINE REQUIRES A CONSTANT SUPPLY OF COOLING AIR. RESTRICTED VENTILATING AIR INLETS OR OUTLETS CAN CAUSE ENGINE FAILURE OR FIRE FROM ENGINE OVERHEATING.**

- \* Do not use generator ventilating air for heating any interior living space. Ventilating air can contain high concentrations of lethal gases.

**WARNING: DO NOT PLACE FLAMMABLE MATERIAL OR STORE ANY OTHER MATERIALS IN THE GENERATOR COMPARTMENT.**

- \* Check engine fuel lines often. Fuel leakage in or around the compartment is an extreme fire hazard. Do not use the generator until fuel leaks are repaired.

**WARNING: EXHAUST GASES ARE DEADLY. INSPECT THE GENERATOR EXHAUST SYSTEM THOROUGHLY BEFORE STARTING THE GENERATOR ENGINE. DO NOT BLOCK THE TAIL PIPE OR SITUATE THE MOTOR HOME IN A PLACE WHERE THE EXHAUST GASES HAVE ANY POSSIBILITY OF ACCUMULATING EITHER OUTSIDE, UNDERNEATH, OR INSIDE YOUR VEHICLE OR ANY NEARBY VEHICLES. OUTSIDE AIR MOVEMENTS CAN CARRY EXHAUST GASES INSIDE THE VEHICLE THROUGH WINDOWS OR OTHER OPENINGS REMOTE FROM THE GENERATOR EXHAUST. OPERATE THE GENERATOR ONLY WHEN SAFE DISPERSION OF EXHAUST GASES CAN BE ASSURED, AND MONITOR OUTSIDE CONDITIONS TO BE SURE THAT EXHAUST GASES CONTINUE TO BE DISPERSED SAFELY.**

- \* Be aware of exhaust gas (carbon monoxide) poisoning symptoms:
  - Inability to think coherently
  - Dizziness
  - Vomiting
  - Intense headache
  - Muscular twitching
  - Weakness and sleepiness
  - Throbbing in temples
- \* If symptoms indicate the possibility of carbon monoxide poisoning, turn off the generator immediately, get out into fresh air at once, and summon medical assistance.

**WARNING: DO NOT UNDER ANY CIRCUMSTANCES OPERATE THE GENERATOR WHILE SLEEPING. YOU WOULD NOT BE ABLE TO**

**MONITOR OUTSIDE CONDITIONS TO ASSURE THAT GENERATOR EXHAUST DOES NOT ENTER THE INTERIOR, AND YOU WOULD NOT BE ALERT TO EXHAUST ODORS OR SYMPTOMS OF CARBON MONOXIDE POISONING.**

- \* Check the generator exhaust system after every 8 hours of operation and whenever the system may have been damaged, and repair any leaks or obstructions before further operation.

**WARNING: DO NOT OPERATE THE GENERATOR WHEN PARKED IN OR NEAR HIGH GRASS OR BRUSH. EXHAUST HEAT MAY CAUSE A FIRE.**

- \* Do not modify the generator installation or exhaust system in any way without first consulting both the generator and RV manufacturers.
- \* Disconnect the generator starting battery before performing any maintenance on the generator.
- \* Allow the generator to cool sufficiently before performing any maintenance on the generator.
- \* Do not use the generator as an emergency power source to a general residential or industrial utility line.

## **Warm Weather Operation**

When operating the generator system in temperatures above 75 degrees F:

- \* Keep cooling fins clean and free of obstructions.
- \* Be sure air flow to and from the generator set is unobstructed.
- \* Use proper grade and weight oil. See generator operating manual.
- \* Check oil level each 8 hours of operation.
- \* Use lead-free, regular grade gasoline. See operating manual.
- \* Keep the generator and compartment clean and uncluttered.
- \* Be sure ignition timing is properly adjusted. See operating manual.

## **Cold Weather Operation**

When operating the generator system in temperatures below 30 degrees F:

- \* Use proper grade and weight oil for cold temperature operation. See generator operating manual.

- \* Use intake air preheater (if equipped) in temperatures below 40 degrees F. See operating manual.
- \* Change oil only when the engine is warm, and after the exhaust system has cooled.
- \* Keep the fuel system clean. Check fuel filters.
- \* Be sure fuel is fresh and water free.
- \* Be sure batteries used in the system are fully charged at all times.

### **Preparation For Storage**

If the motor home will be stored for more than 30 days, the following procedures will help prevent generator engine or electrical component damage during the storage period. Also see "Preparation For Long Term Storage" section of this manual.

- \* Run the generator until it reaches normal operating temperature.
- \* Disconnect generator fuel line at the filter and run engine out of fuel.
- \* Disconnect battery cable or otherwise disable starting circuit.
- \* Drain oil from warm engine.
- \* Refill engine crankcase with fresh oil and change oil filter. Use a grade and weight appropriate for your next operating season temperature range. See generator operating manual. Attach reminder tag with weight and grade.
- \* Remove spark plug(s). Place corrosion inhibitor oil in cylinder(s). Rotate crankshaft a few times. Reinstall spark plug(s).

**CAUTION: IF GENERATOR MUST BE TILTED FOR SERVICE, DO NOT TILT FOR MORE THAN 30 MINUTES DURING SERVICE.**

- \* Service air cleaner as outlined in operating manual.
- \* Clean governor linkage and cover with clean cloth.
- \* Plug exhaust outlet.
- \* Wipe off entire unit. Coat rustable parts with light oil or grease.
- \* Remove batteries. See "Preparation For Long Term Storage".

### **Reactivating Generator System After Long Term Storage**

- \* Remove all covers and protective wrappings.
- \* Wipe off oil or grease from exposed engine parts.
- \* Remove plug from exhaust outlet.
- \* Visually inspect unit for damage, insect or animal intrusion. Be sure carburetor and governor linkages are free.
- \* Check oil tag to be sure oil or the proper grade and weight is in crankcase. Check oil level.
- \* Remove spark plug(s), clean and gap (see operating manual). Turn the engine over by hand several times. Reinstall spark plug(s).
- \* Install batteries. Be sure batteries are fully charged. Observe proper polarity. Ground is negative terminal.
- \* Remove all load and start the generator with the controls at the unit. This initial start may be slow due to oil or rust inhibitor in the cylinders. Excessive smoke and rough operation is normal until the oil or rust inhibitor is burned off.
- \* Apply a 50% load after the generator runs smoothly. Allow the generator to warm up for one hour with the load connected.

Unit is now ready for service.

### **Generator Maintenance and Service**

The generator system is a complex electromechanical device. Although routine maintenance and service procedures are not beyond the capabilities of most users, some adjustments and service procedures are best performed by authorized generator service facilities. They have the required tools and equipment necessary to keep your generator operating at peak efficiency. If you experience repeated difficulty in starting, or signs of incorrect power output or speed and voltage fluctuations, refer these problems to an authorized generator service center. You can contact the generator manufacturer for the location of a service facility near you.

### **ELECTRICAL SYSTEM WIRING**

Because of the many model, floor plan and option variations available, it is beyond the scope of this manual to include all wiring diagrams possible. In certain situations, specific wiring diagrams may be available to help troubleshoot a problem. If you need specific wiring information, please contact your dealer. Complete wiring diagrams are not available.

# LIQUID PETROLEUM GAS SYSTEM

Liquefied petroleum (LP) gas is available from an approved storage tank to operate your range, oven, furnace, and water heater, and as an alternate energy source for some refrigerators. With proper handling precautions, LP gas is safe and provides modern conveniences wherever you travel. The LP gas storage tank is mounted on the motor home chassis. It is stored as a liquid under pressure and vaporizes under the control of a pressure regulator.

A typical LP gas tank installation is illustrated below. Although specific details of the system may differ in your motor home, the major components and their relationships will be similar to those shown.

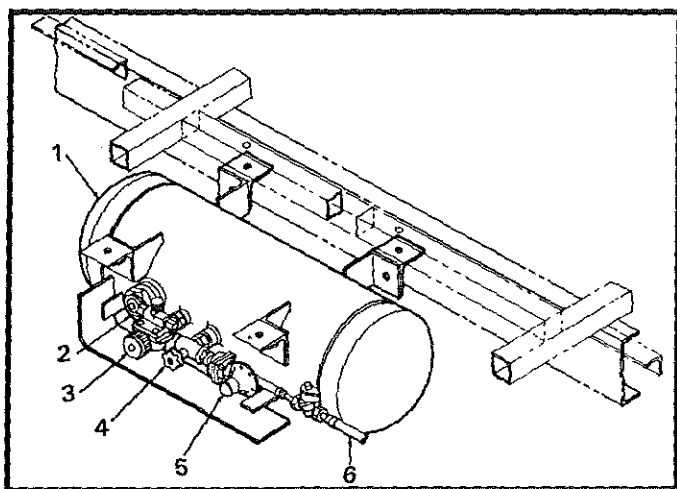

- |                    |                        |
|--------------------|------------------------|
| 1. LP gas tank     | 4. Main shut-off valve |
| 2. Sight gauge     | 5. Regulator assembly  |
| 3. Auto-Stop valve | 6. LPG hose            |

## LP GAS SAFETY PRECAUTIONS

Historically, LP gas is a safe and reliable fuel. As with any other volatile and flammable material, common sense dictates that LP gas be handled and used with respect and caution. Because LP gas systems are so reliable, they are often taken for granted. Neglect can be a very dangerous habit. If the system is maintained regularly, you can expect almost troublefree operation.

**WARNING: LP GAS IS FLAMMABLE AND POTENTIALLY EXPLOSIVE. USE PROPER HANDLING, LIGHTING, AND VENTILATION PROCEDURES.**

1. The distinctive odor of LP gas indicates a leak. **IF YOU SMELL GAS:**
  - \* Extinguish all open flames, pilot lights and all smoking materials.
  - \* Do not touch electrical switches.
  - \* Shut off the gas supply at the tank valve(s) or gas supply connection.

- \* Open all doors, windows, and vents.
- \* Leave the area until the odor clears.
- \* Have the gas system checked and the cause of the leak corrected before using the system again.

2. Inspect the entire LP gas system for leaks or damaged parts before each trip.
3. Always be careful when drilling holes or fastening objects to the motor home. The gas supply lines could be punctured by a nail or screw.
4. Do not restrict access to LP tanks. In an emergency, the tank service valve must be easily accessible. The tank compartment door must always be unlocked.
5. Do not carry or store filled or empty LP gas containers inside your motor home. LP gas containers are equipped with a safety device that relieves excessive pressure by discharging gas to the atmosphere. Leaks can occur at valves and fittings. Always store LP tanks with the valves closed.
6. Do not use any LP gas tank other than the one furnished with your motor home without being sure that all connecting components are compatible.
7. **WARNING: TURN OFF LP GAS MAIN VALVE AND INDIVIDUALLY TURN OFF ALL GAS APPLIANCES OR ELECTRICALLY DISCONNECT AUTOMATIC IGNITION APPLIANCES BEFORE ENTERING AN LP GAS BULK PLANT OR MOTOR FUEL SERVICE STATION.**
8. **WARNING: DO NOT FILL LP GAS CONTAINERS TO MORE THAN 80% CAPACITY. OVERFILLING CAN RESULT IN UNCONTROLLED GAS FLOW WHICH CAN CAUSE FIRE AND EXPLOSION. A PROPERLY FILLED CONTAINER HOLDS ABOUT 80% OF ITS VOLUME AS LIQUID.**
9. Never check for leaks with an open flame. Use an approved leak detection solution or a non-ammoniated, non-chlorinated soap solution only. If the leak cannot be located, take the unit to an LP gas service representative.
10. LP gas regulators must always be installed with the diaphragm vent facing downward. Make sure that the regulator vent faces downward and that the cover is kept in place to minimize vent blockage which could result in excessive gas pressure causing fire or explosion.
11. Do not use a wrench or pliers to close the service valve. This valve is designed to be closed leak-tight by hand. If a tool is required to stop a leak, the valve probably needs repair or replacement.
12. Use proper tools to tighten fittings. Don't force, jam or crossthread fittings. Always check fittings for leaks after tightening.

13. Be sure the tank is securely fastened in its mounting before each trip.
14. If you do not have the special tools and training necessary, do not attempt to repair LP gas system components.
15. Always think safety.

## SYSTEM COMPONENTS

### Hoses and Fittings

The hoses used in your LPG system are UL or CGA listed, and are rated to withstand many times the pressures encountered in the system. Although they are designed for efficient and troublefree use, they can deteriorate from the effects of the sun and impurities in the air. The average life of LP hoses is two to three years. Consequently, check the hoses for weather checking or other signs of deterioration every time you have the gas tank filled or serviced. Protect the hoses and other parts of the system from sunlight whenever possible. When you replace hoses, be sure that replacements are properly rated and approved for RV use.

### LP Gas Regulator

The regulator is the heart of the LP gas system. It works continuously and requires more care and attention than any other part of the system.

Its main job is to reduce the high and varying pressure of the gas from the tank to a low, consistent pressure to serve the appliances in the motor home. Normal tank pressure can range from 250 psi to 7 psi depending on the outside temperature. The regulator smooths out these wide variations and supplies your gas appliances with a steady 6.35 ounces, or 11 inches water column pressure.

It does this smoothing in two stages. The first stage reduces the high pressure to about 10-13 psi. This allows the second stage to be much more efficient and accurate in controlling the pressure to the appliances. This two-stage reduction also helps reduce the likelihood of freeze-up or pilot outage.

Because the regulator is constantly "breathing", it is equipped with a vent. When the diaphragm inside the regulator moves up and down, air is drawn into or expelled from the chamber through this vent. If excess pressure builds up in the regulator, a relief mechanism allows it to escape through the vent. It is therefore very important that the vent is clean and free of obstruction. Clogging from corrosion, dirt, insect nests, or other debris is the most common cause of regulator malfunction. Even a small piece of material that finds its way into the inlet can result in improper pressures in the system and possible damage to or failure of components. The regulator is mounted so that the vent is facing downward and is protected from freezing road spray and other foreign matter by a water-resistant cover. Be sure the cover is on at all times. If the vent does become clogged,

it can be cleaned with a toothbrush.

**WARNING: DO NOT ATTEMPT TO ADJUST THE REGULATOR. IT HAS BEEN PRESET BY THE REGULATOR MANUFACTURER. IF ANY ADJUSTMENT IS REQUIRED, IT MUST BE MADE BY A QUALIFIED LPG SERVICE TECHNICIAN USING SPECIAL EQUIPMENT.**

### USING LP GAS SYSTEM AT LOW TEMPERATURES

Your gas system will function at low temperatures, provided the system components are kept at a temperature above the vapor point of the LP gas. NOTE: Butane vaporizes at about 32°F and propane vaporizes at about -40°F. Choose a type of LP gas which has a boiling point approximately 40°F lower than any temperature you expect to encounter. Ask your LP gas supplier or your motor home dealer for information on product blends available in your area.

LP gas systems can and do freeze up in very cold weather. It is a common misconception that the regulator or the gas itself freezes. Actually, it is the moisture or water vapor that gets trapped in the system or absorbed by the gas that freezes and causes the problem. This ice can build up and partially or totally block the gas supply.

Where does the water come from? From a variety of sources: The gas can be saturated with water when it comes out of the gas plant or refinery unless care is taken to see that it is thoroughly dehydrated; the gas can absorb water while it is transported if the tank cars contain water; the gas storage tanks may have water in them because moist air has been trapped in the tank because a valve was left open.

There are a number of things you can do to prevent freeze up:

1. Be sure the gas tank is totally moisture-free before it is filled.
2. Be sure the tank is not overfilled. This is also a safety consideration.
3. Keep the valve on an empty tank tightly closed.
4. Have the gas tank purged by the LP gas service station if freeze up occurs.
5. Have the LP service station inject an approved antifreeze or de-icer into the tank. Be sure you have the proper gas blend for your traveling area. If you have the proper gas blend, it is very unlikely that the gas is at fault.

If, despite precaution, you do experience freeze up, try melting the ice by warming the regulator using a small light bulb. **DO NOT USE AN OPEN FLAME.** Once flow is restored, make certain that the regulator cover is properly reinstalled to prevent water from entering the regulator which will cause it to freeze again. If the problem persists, ask your LP gas supplier to service the tank or regulator as required.

Aside from the possibilities of freezing during cold temperatures, your LP gas system performance is affected significantly as the temperature drops. The liquid in the tank is, of course, much colder than the air that normally surrounds the tank. The liquid in the tank vaporizes by absorbing heat from the surrounding air. But as the air temperature drops closer to the temperature of the liquid in the tank, the liquid doesn't vaporize as easily. Consequently, the BTU value of the LP drops dramatically.

The following chart shows the reduction in BTU availability of propane gas as the temperature falls:

% FULL	20 lb. Bottle*				
	+20°	0°	-5°	-10°	-15°
60%	36,000	18,000	12,750	8,500	4,250
50%	32,400	18,200	12,150	8,100	4,050
40%	28,800	14,400	11,400	7,600	3,800
30%	25,200	12,600	10,450	7,300	3,150
20%	21,600	10,800	8,100	5,400	2,700
10%	16,200	8,100	6,075	4,050	2,025

\*30 lb. Bottle multiply  $\times$  1.40

The chart clearly shows how the availability of the gas is reduced at lower temperatures. With this in mind, keep your LP tank as full as possible during cold weather. Check the BTU/hr rating plates on your LP appliances. This information will help you manage your LP gas requirements efficiently.

### **FILLING LP GAS TANKS**

To fill the chassis-mounted storage tank, drive the vehicle to an LP gas supplier or one of the service stations which sell LP gas.

When your LPG tank is filled for the first time, make sure that it is properly purged of air before adding LPG. This will help prevent rust and insure proper system and appliance performance. Your LP gas service facility should be familiar with this procedure.

**WARNING: TURN OFF LP GAS MAIN VALVE BEFORE FILLING LP GAS TANK OR ENTERING AN LP GAS BULK PLANT OR MOTOR FUEL SERVICE STATION. TURN OFF ALL PILOT LIGHTS AND APPLIANCES INDIVIDUALLY BEFORE REFUELING OF MOTOR FUEL TANKS AND/OR PERMANENTLY MOUNTED LP-GAS CONTAINERS. WHEN NOT INDIVIDUALLY TURNED OFF, AUTOMATIC IGNITION APPLIANCES MAY CONTINUE TO SPARK WHEN LP GAS IS TURNED OFF AT THE CONTAINER. DO NOT FILL LP GAS CONTAINERS TO MORE THAN 80% OF CAPACITY.**

### **LP GAS SYSTEM LEAK CHECKS**

The smell of LP gas (actually, an additive, ethyl mercaptan) indicates a leak. Obvious leak sources are fittings, valves, and couplings.

For your safety, check for leaks in your gas system each time the tank is filled or before each trip. Always check the system any time you detect a garlic-like odor.

To perform a leak check, swab a mixture of a non-ammoniated, non-chlorinated soap solution or an approved leak detection solution over each fitting, joint and connection in the system. Open the tank service valve. Inspect each joint. If even the smallest bubbles appear at any joint, this joint must be remade. Refer repairs to an authorized Fleetwood service center, or your LP gas service facility. Never attempt to repair gas piping without proper tools and know-how.

Potential trouble spots for leaks are areas where piping runs close to chassis and frame members. Look for chafes and cracks around pipe hangers. If you find defects in any LP gas system component, have it repaired or replaced before using the system.

As an added precaution, do a visual check of all exposed piping and fittings after you have arrived at a destination and before you use the LPG system. Travel and road shocks may have caused damage to the system that you will need to repair before using the appliances.

**WARNING: NEVER CHECK FOR LEAKS WITH AN OPEN FLAME. DO NOT CHECK COPPER AND BRASS PLUMBING LINES AND FITTINGS FOR LEAKS USING AMMONIATED OR CHLORINATED HOUSEHOLD TYPE DETERGENTS. THESE CAN CAUSE CRACKS TO FORM ON THE LINE AND BRASS FITTINGS. IF THE LEAK CANNOT BE LOCATED, TAKE THE UNIT TO AN LP GAS SERVICE REPRESENTATIVE.**

Keep the tank valve closed and turn off all appliances if the unit is not being used. **WARNING: DO NOT USE PLIERS OR A WRENCH TO TIGHTEN VALVES. IF A VALVE IS NOT LEAK-TIGHT WHEN CLOSED BY HAND, SEE AN LP GAS SERVICE REPRESENTATIVE.**

### **LPG LEAK DETECTOR**

A permanently installed LP gas leak detector is located near the floor in the galley area. The unit contains an alarm that will sound alerting you to the presence of low levels of potentially dangerous LP gas that may have been released due to a range top or oven burner flame loss, a gas piping leak, or an incorrectly adjusted appliance burner. The unit will also disconnect the gas supply at the LP tank when it senses LP or similar gases.

**PLEASE READ THE LPG DETECTOR'S OWNER'S MANUAL FOR DETAILS ON TESTING AND CARING FOR THIS IMPORTANT SAFETY DEVICE.**

The detector unit is powered by the 12-volt DC system in your motor home. A power switch is

located on the panel. A green light on the detector front panel indicates that the detector has power. If the power switch is OFF, gas flow from the tank is cut off by a special solenoid valve located at the tank.

Test the leak detector each time the motor home is relocated and set up for use.

Testing procedure:

- \* Hold a butane-fueled pocket lighter near the sensor.
- \* Open the lighter valve without striking the flame.
- \* The leak detector should respond within a few seconds.
- \* Press the reset switch to reset the alarm.
- \* Lightly fan the area around the detector to insure complete dispersion of the gas from the lighter, and to prevent another sounding of the alarm.

A reset switch allows you to temporarily quiet the alarm for 60 seconds after it has been set off or after testing.

If the alarm does not sound during a test or if the green indicator light is not visible, see your dealer or an authorized Fleetwood Service Center. There are no batteries or user serviceable parts inside the unit.

**NOTE: REMEMBER TO TURN OFF THE DETECTOR IF YOU ARE NOT USING YOUR MOTOR HOME. THE DETECTOR DRAWS ENOUGH CURRENT TO DISCHARGE YOUR BATTERY.**

### ***LIGHTING LP GAS APPLIANCES***

Detailed operating information for the LP appliances can be found in your Owner's Information Package. Please read and follow these instructions.

Air trapped in the gas lines may delay the initial lighting of any appliance. It could take several seconds or minutes for the gas to reach the appliance. To purge some of the air from the gas system, first light a burner on the range. The other appliances will then light more quickly.

**ALWAYS FOLLOW THE APPLIANCE MANUFACTURER'S LIGHTING AND OPERATING INSTRUCTIONS.**

# APPLIANCES

The appliances installed in your motor home are tested by independent laboratories and comply with rigid standards established by these organizations. All appliances installed by the manufacturer in your motor home are covered under Fleetwood's Ownercare Warranty program. Each appliance is also warranted by its manufacturer, and a warranty registration card for each appliance is included in your Owner's Information Package. Fill out the designated portions of the cards and mail them to the respective appliance manufacturers. **Please consult the manufacturer's instructions for additional detailed information.**

**WARNING: THE WATER HEATER AND FURNACE COMBUSTION AIR EXHAUST PORTS MAY BE EXTREMELY HOT DURING WATER HEATER AND FURNACE OPERATION. DO NOT TOUCH THESE OUTLETS OR ALLOW ANY MATERIAL TO COME IN CONTACT WITH OR COVER EITHER THE AIR INTAKE OR EXHAUST PORTS WHILE OPERATING THE WATER HEATER AND/OR FURNACE.**

## WATER HEATER

The water heater operates on LP gas, and is much like the one in your home. It contains an automatic shut off valve which stops the gas supply if the water temperature rises too high. The water heater is reached through an access panel on the outside of the motor home. **CAUTION: DO NOT LIGHT WATER HEATER UNTIL IT IS FILLED WITH WATER.** Turn on the hot water faucet at the galley sink. If water flows continuously, the heater is full. **For detailed operating instructions, refer to the manufacturer's instruction manual.**

Occasionally you may experience "weeping" of the pressure/temperature relief valve on the water heater. This is not a defect. It is caused by the normal expansion of water while it is being heated in the closed water system of your motor home. The water heater tank is designed internally with an air gap at the top of the tank to reduce this weeping phenomenon. In time, though, the heating and expansion of the water will absorb this air. To replace the air, and reduce relief valve weeping:

- \* Turn off the water heater.
- \* Turn off incoming water supply.
- \* Open a faucet in the motor home.
- \* Pull the handle of the relief valve straight out and let water flow until it stops.

- \* Release the relief valve handle and let the valve snap shut.
- \* Turn on the water supply.

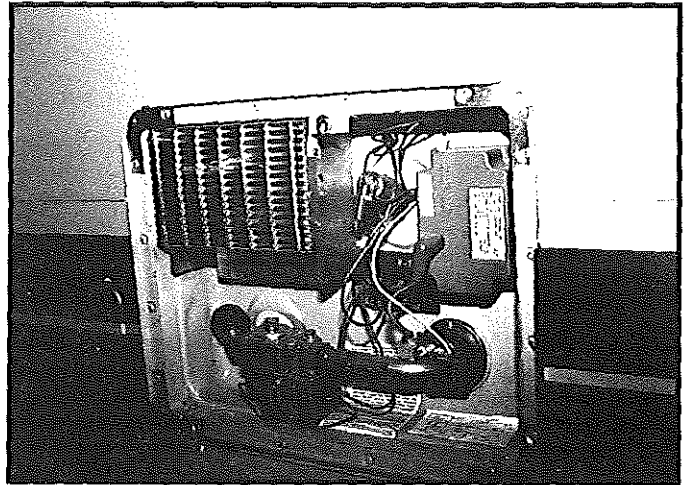

Water Heater

- \* Close the faucet when water flows continuously without sputtering.
- \* Turn on the water heater.

## FURNACE

The furnace is a forced-air unit fueled by LP gas. All furnaces are equipped with a wall thermostat for individual temperature settings. **The operating manual included in your Owner's Information Package contains detailed operating and maintenance instructions.**

**WARNING: PORTABLE FUEL-BURNING APPLIANCES ARE NOT SAFE FOR HEATING INSIDE THE MOTOR HOME. ASPHYXIATION OR CARBON MONOXIDE POISONING CAN OCCUR.**

## RANGE

The gas oven and burners are operated with LP gas. The basic operation is the same as the range in your home. **For additional information, please refer to the operating manual in your Owner's Information Package.**

A warning label has been located in the cooking area to remind you to provide an adequate supply of fresh air for combustion. Unlike homes, the amount of oxygen is limited in an RV due to the size and construction of the vehicle. Proper ventilation when using the cooking appliances will prevent the dangers of asphyxiation. **WARNING: DO NOT USE OPEN FLAMES TO WARM THE LIVING AREA. GAS COMBUSTION CONSUMES THE OXYGEN INSIDE THE MOTOR HOME.**

## **RANGE EXHAUST HOOD**

The exhaust hood allows vapors and cooking odors to escape, and provides a vent for the galley area. Switches for the fan and light are located on the front of the hood. The hood has a grease filter screen which requires periodic cleaning. To clean, remove the screen and wash in soapy water. Rinse with water and let the screen drain dry. The fan blades may also be cleaned with soapy water. Replace the cleaned filter in the exhaust hood.

Replace the light bulb with an equivalent type.

The range hood may also house the monitor panel. Operating instructions for the monitor panel functions are in the Plumbing and Electrical sections of this manual.

## **AIR CONDITIONER (Optional)**

The optional roof-mounted air conditioner can operate only when the motor home is connected to 120-volt AC power from either a public utility or the generator. Be sure to turn the air conditioner circuit breaker ON.

For best performance, park the motor home in the shade and close curtains. Close doors and windows and turn the temperature control knob for desired coolness. **Refer to the air conditioner manufacturer's instructions for detailed operation and preventive maintenance requirements.** Remember that air conditioners require a large portion of your available electric power.

## **REFRIGERATOR**

The refrigerator may be operated from either LP gas or 12-volt/120-volt electric power. **Consult the operating instructions furnished in your Owner's Information Package.** Before operating the refrigerator when the motor home is parked, make sure it is level. If it is not level, the refrigerant will not circulate, cooling action will stop, and the refrigeration system may be damaged.

The refrigerator uses the absorption principle of operation. If you plan to cool food or drinks in high

outside ambient temperatures, pre-cool the food, and park the motor home with the refrigerator vent door in the shade. Once the interior of the refrigerator is cool, the refrigeration system will usually maintain this temperature. If the inside of the refrigerator is hot, the food is not pre-cooled, and the outside temperature is high, be prepared for longer cooling times.

## **SMOKE DETECTOR**

A battery-powered smoke detector complying with ANSI A119.2/NFPA 501C is mounted in the living/cooking area of your motor home. **Please read the smoke detector Owner's Manual for details on testing and caring for this important safety device.**

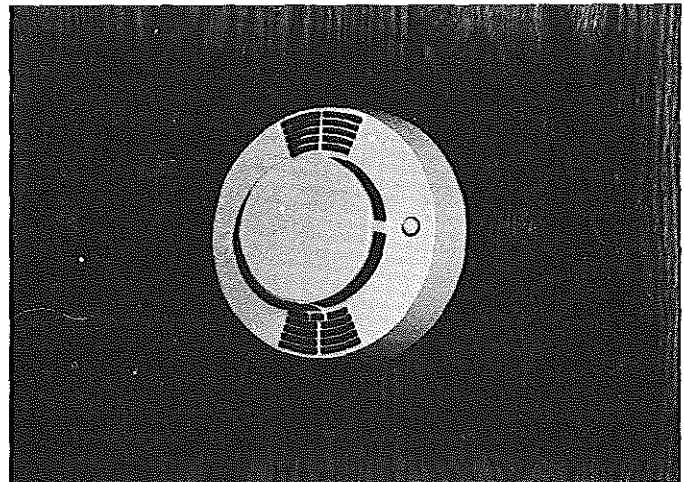

*Smoke Detector*

Test the smoke detector after the motor home has been in storage, before each trip, and at least once a week during use.

Twist the cover of the smoke detector counterclockwise to remove it from the wall bracket.

If the smoke detector fails to operate with new batteries, replace it with a new unit, available through an authorized Fleetwood Service Center.

# MAINTENANCE

Your Tioga Arrow has been engineered to provide you with many years of troublefree service with a minimum amount of maintenance. This section will familiarize you with the areas of your motor home that require scheduled care. A few minutes spent taking care of your motor home on a regular basis will pay for itself in extended service and will protect your investment. If you are mechanically inclined and regularly perform routine maintenance and repairs on your car or truck, you may want to do the mechanical work on your motor home. If you prefer, your dealer can perform these services for you. His trained personnel will assure that your motor home is maintained and repaired in keeping with original performance expectations.

This section is intended to provide the owner and operator with a general overview of service and maintenance information for the motor home. In addition to providing information for proper maintenance of the motor home, some inspection and diagnostic procedures are included to help detect and identify problem conditions. **Detailed service and maintenance information may be found in the chassis operator's manual and chassis manufacturer's service and maintenance manuals, available from the chassis manufacturer.**

While the information contained in this section is intended to establish proper maintenance and inspection procedures, there may be times when more detailed diagnostic and repair procedures may be required. Consult your dealer or an authorized Fleetwood Service Center in these situations.

## **LUBRICATION**

Various components of the motor home chassis must have the proper lubrication to operate as designed. This lubrication must be done in accordance with the intervals specified in the appropriate Maintenance Schedule for the vehicle. **Consult the chassis manufacturer's operator's or maintenance manual for specific information concerning lubricants and lubrication.**

## **WHEELS AND TIRES**

The factory installed tires and wheels are designed to operate satisfactorily with loads up to and including the full rated load capacity when inflated to the recommended inflation pressures.

Correct tire pressures and driving techniques have an important influence on tire life. Heavy cornering, excessively rapid acceleration, and unnecessary sharp braking increase tire wear.

### ***Tire Inspection and Rotation***

Front and rear tires perform different jobs and can wear differently depending on the type of roads

driven, individual driving habits, etc. To obtain maximum tire life, inspect tires for wear and damage regularly. If general tread wear indicates only 1/16" between any two adjacent tread ribs, replace the tire. Look for abnormal wear patterns such as cupping or feathering of the tread or rapid wear on either the inside or outside of the tread surface. If these conditions exist, an inflation, bearing adjustment or alignment problem is evident. Refer repairs to an authorized Fleetwood Service Center. Replace the tire if cuts, bulges, peeling tread or other signs of damage or failure are evident. Remove stones and other objects lodged in the tread. Be certain to check wheel nut tightness (using a torque wrench) and to adjust the tire pressures, front and rear, after rotation to agree with the recommended pressures. Recheck the torque at 100 and 1,000 miles of operation after wheel installation and once every 6,000 miles thereafter.

Due to their design, radial tires tend to wear faster in the shoulder area, particularly in the front positions. This makes regular rotation especially necessary. **Consult your dealer or the chassis manufacturer's operator's or maintenance manual for proper tire rotation procedures.**

**NOTE FOR FORD CHASSIS OWNERS:** Retighten wheel nuts as recommended in your Ford Owner's Guide at the specified mileage intervals. If your motor home is equipped with chrome wheel simulators, remove the jam nuts and simulators to gain access to the lug nuts.

### ***Inflation Pressure***

Tires must be inflated to the maximum cold inflation pressures for the tires when the GVWR or an axle GAWR is reached. Improper tire inflation pressures for the load the vehicle is carrying can adversely affect tire life and vehicle performance. The most common cause of tire failure is improper inflation.

Too low an air pressure can result in tire overloading, abnormal tire wear, adverse vehicle handling, reduced vehicle stability, and reduced fuel economy. The tire flexes more and can build up excessive heat, weakening the tire and increasing susceptibility to damage or failure. Too high an air pressure can result in abnormal wear, harsh vehicle ride, and increased susceptibility to damage from road hazards. Lower inflation pressures should be used only with reduced vehicle loads. After determining the load on each tire by weighing the vehicle on a scale, inflate the tires to the correct cold inflation pressures for the actual tire loads. Refer to the chassis operator's manual for additional information on inflation pressure. Keep an accurate tire gauge in your tool kit. Check tire pressures cold. **DO NOT BLEED AIR OUT OF WARM TIRES.**

## **Wheel and Tire Balancing**

From the standpoints of tire wear and vehicle ride and handling ease, maintain proper balance of wheel and tire assemblies. The two types of balancing systems in current use balance wheels either on or off the vehicle. The "on the vehicle" type, however, is the more desirable in that all rolling components (rotating brake components, bearings, seals, etc.) are included in the balancing process. Because of the specialized equipment required, wheel and tire balancing should be performed by a qualified service shop.

## **Tire Replacement**

When replacing tires, be sure to consult your chassis operator's manual for information regarding the proper tire selection. Use of the incorrect size or type tire may affect load carrying capacity, ride, handling, speedometer/odometer calibration, vehicle ground clearance, and tire clearance to the body and chassis. If replacing only a single tire, it should be paired on the same axle with the least worn tire of the others.

**WARNING: DO NOT MIX DIFFERENT TYPES OF TIRES ON THE SAME VEHICLE SUCH AS RADIAL, BIAS, AND BIAS-BELTED TIRES EXCEPT IN EMERGENCIES, BECAUSE VEHICLE HANDLING AND TIRE LIFE MAY BE SERIOUSLY AFFECTED AND MAY RESULT IN LOSS OF CONTROL OR TIRE FAILURE.**

## **ENGINE (Refer to Chassis Operator's Manual)**

Refer to the chassis operator's manual for specific fuel recommendations.

### **Engine Oils**

Refer to the chassis operator's manual and vehicle maintenance schedule for the oil type, viscosity and change intervals recommended for the operating conditions encountered.

## **ENGINE FUEL SYSTEMS**

### **Fuel and Air Filters**

Inspect and replace fuel and air filters according to the chassis manufacturer's Maintenance Schedule.

Inspect and maintain the fuel and emission control systems in accordance with the chassis manufacturer's Maintenance Schedule. Check fuel lines for signs of leakage, damage or deterioration. Tighten clamps if they are loose. Replace filters in the fuel line and the evaporative control system at the recommended intervals.

### **Air Cleaner Element Replacement**

Replace the air cleaner element according to the chassis manufacturer's maintenance schedule.

## **COOLING SYSTEM**

### **Maintenance and Inspection**

Check the coolant level, appearance, and strength periodically. Drain and replace at the intervals recom-

mended in the Maintenance Schedule, or sooner if it is dirty. Check hoses regularly for signs of damage or deterioration, and tighten hose clamps if necessary.

Check hoses for cuts or abrasion damage. If the hoses have become hard and brittle and show signs of cracking as a result of engine heat, replace them. Replace hoses if they are soft and spongy, or swollen as a result of exposure to oil and grease. Any flaking or deterioration of the inner lining of the hose is also a reason for replacement. Such particles can clog the cooling system, reducing its efficiency.

Wash the radiator cap with clean water and pressure-check every 12 months.

### **Coolant Level**

Remove the radiator cap periodically to observe coolant level in the radiator.

**WARNING: TO HELP AVOID THE DANGER OF BEING BURNED, DO NOT REMOVE THE RADIATOR CAP WHILE THE ENGINE AND RADIATOR ARE STILL HOT. SCALDING FLUID AND STEAM CAN BE BLOWN OUT UNDER PRESSURE IF THE CAP IS TAKEN OFF TOO SOON.**

Maintain coolant levels in the radiator to the top of the filler neck.

Regardless of whether freezing temperatures are expected or not, maintain cooling system protection to at least -34°F, to provide adequate corrosion protection and loss of coolant from boiling.

When adding solution due to loss of coolant for any reason or in areas where temperatures lower than -34°F occur, use a sufficient amount of an ethylene glycol base antifreeze that meets the chassis manufacturer's specification.

\* Alcohol or methanol base antifreeze, or plain water, are not recommended for your engine at any time. They will not provide proper protection against corrosion.

\* Additives in addition to a good quality ethylene glycol-base antifreeze meeting the chassis manufacturer's specification are not required or recommended. Many of the claims for additives are associated with better heat transfer or cooling, but these claims are not supported by test data. In some instances, the ingredients may be incompatible with the recommended coolant. Also, when used alone with water as is sometimes suggested, the additive may not provide the corrosion protection given by the recommended coolant solution.

### **Flushing Cooling System**

Various methods and equipment may be used to perform this service. If special equipment such as a back flusher is used, follow equipment manufacturer's instructions.

## ENGINE ELECTRICAL

### Jump Starting

**NOTE:** Do not push or tow the vehicle to start. There are no provisions in the automatic transmission for engagement of the transmission to turn over the engine. Efforts to push or tow the vehicle to start it will have no effect.

Both booster and discharged battery should be treated carefully when using jumper cables. Follow the conditions and procedure outlined below, being careful not to cause sparks. Departure from these conditions or procedures could result in serious personal injury (particularly to eyes) or property damage caused by battery explosion, battery acid, or electrical burns; and/or damage to electronic components of either vehicle.

#### CAUTION:

- \* Be sure the jumper cables and clamps to be used for jump starting do not have loose or missing insulation. Do not proceed if suitable cables are not available.
  - \* If either battery has filler caps, check the fluid level. (Do not check with an open flame.) If low, fill to the proper level with clear drinking water. Replace all caps before jump starting.
  - \* Do not route the cable (or attach the clamp) on or near pulleys, fans, or other parts that will move when the engine is started.
1. Set the parking brake firmly and place the automatic transmission in PARK. Turn off the ignition, turn off lights, and all other electrical loads.
  2. Only 12-volt batteries can be used to start the engine. Do not use 24-volt charging equipment. Using such equipment can cause serious damage to the electrical system or electronic parts.
  3. Attach the end of one jumper cable to the positive terminal of the booster battery and the other end of the same cable to the positive terminal of the discharged battery. Do not permit vehicles to touch each other as this could cause a ground connection and counteract the benefits of this procedure.
  4. Attach one end of the remaining negative cable to the negative terminal of the booster battery, and the other end to a solid ground at least 18 inches from the battery of the vehicle being started. **DO NOT CONNECT DIRECTLY TO THE NEGATIVE TERMINAL OF THE DEAD BATTERY.**
  5. Start the engine of the vehicle that is providing the jump start and turn off electrical accessories. Then start the engine in the vehicle with the discharged battery.

6. Reverse these directions exactly when removing the jumper cables. Disconnect the negative cable from the engine that was jump started first.

## TRANSMISSION

### Maintenance and Inspection

Check the automatic transmission fluid level regularly (at each engine oil change) and change it at the intervals recommended in the chassis manufacturer's Maintenance Schedule for your vehicle.

**WARNING: AT NORMAL OPERATING TEMPERATURES, THE DIPSTICK WILL BE EXTREMELY HOT TO THE TOUCH. USE CARE TO AVOID BURNS.**

In addition, check the oil (fluid) cooler lines, electrical lines, vacuum lines, control linkage and transmission periodically for leaks, damage or deterioration.

**NOTE:** Transmission problems can be the result of poor engine performance. If the engine requires a tune-up, this should be done before extensive transmission testing.

### HEATING AND AIR CONDITIONING (IF EQUIPPED)

The heater/air conditioner system consists of a heater core and evaporator housed in a case which, typically, includes an air inlet, blower motor assembly, air distribution ducts and doors to control the flow of air through the case.

#### Inspection

Perform the following checks regularly:

1. Check outer surfaces of radiator and condenser cores to be sure they are not plugged with dirt, leaves or other foreign material. Be sure to check between the condenser and radiator as well as outer surfaces.
2. Check the metal tubing lines to be sure they are free of dents or kinks which can cause a loss of system capacity due to a line restriction.
3. Check the flexible hose lines for brittleness or deterioration which can be the source of a system leak.
4. Check for proper drive-belt tension.

#### Air Conditioner Operational Quick Checks

The following checks may indicate if the amount of refrigerant (charge) in the system is low. The ambient temperature should be above 70°F.

**NOTE:** Engagement of the compressor clutch in both of the tests below indicates that the clutch electrical circuit is OK. If the clutch does not engage, then check for a blown fuse, loose connections or damaged or deteriorated wires. If these checks are OK, then the problem may be in the compressor clutch or switch. Take the vehicle to a qualified shop for further testing.

## **Electrical Circuit Diagnosis**

The blower electrical circuit and motor is OK if the blower operates at all of the designated speeds. If the blower does not work at all, then check for a blown fuse, loose connections, and for damaged or deteriorated wires. If these checks are OK and/or the blower does not operate at all speeds, then the problem may be in the switch, relay or motor. Take the vehicle to a qualified shop for further testing.

## **Refrigeration Section**

**WARNING: BECAUSE OF THE NATURE OF REFRIGERANT-12 AND THE HIGH PRESSURES WHICH ARE PRESENT IN THE REFRIGERANT SECTION OF THE SYSTEM, PERSONAL INJURY CAN RESULT IF PROPER DIAGNOSTIC AND SERVICE PROCEDURES ARE NOT FOLLOWED. THEREFORE, REFER ALL SUCH WORK REQUIRED ON THE SYSTEM TO A QUALIFIED SHOP WITH THE NECESSARY TRAINED PERSONNEL AND EQUIPMENT.**

## **FRONT SUSPENSION AND ALIGNMENT**

The term "front alignment" refers to the angular relationships between the front wheels, the front suspension attaching parts and the ground.

Several factors can affect front alignment, including tire inflation pressures, wheel bearing condition, steering and suspension components. The following checks can indicate problems that should be corrected.

1. Check all tires for proper inflation pressures and approximately the same tread wear.
2. If the unit is equipped with air suspension components, be sure to inspect them according to the literature included in the Owner's Information Package. Be sure to keep them inflated to the recommended pressures.
3. Check for a difference in the ride height between right and left sides of the vehicle.

**NOTE: Excessive or unevenly distributed loads also affect ride height and alignment. This should be taken into consideration when making the check. Also, if the motor home is equipped with air bag cylinders, it is important that the cylinders be inflated to the proper pressure for the load being carried in order to maintain adequate ride height.**

Further diagnosis and alignment checks can be made at a qualified alignment/front end shop.

## **BRAKES**

Check and fill the master cylinder according to instructions in the chassis operator's manual.

### **Brake Hose Inspection**

Inspect the flexible hydraulic brake hoses which

transmit hydraulic pressure from the steel brake pipe on the frame to the brake assemblies at the wheels regularly in accordance with the chassis manufacturer's Maintenance Schedule. Check for road hazard damage, cracks and chafing of the outer cover, and for leaks and blisters. A light and mirror may be needed for an adequate inspection. If any of the above conditions are observed on any brake hose, have it replaced.

### **Lining Inspection**

Inspect the brake linings per the chassis manufacturer's Maintenance Schedule and any time that the wheels are removed (tire rotation, etc.).

### **DRIVE BELTS**

Proper care and maintenance of drive belts is an important part of good engine maintenance. Proper belt tension and the condition of the pulley grooves are of primary concern.

Since belts and pulleys wear with use, look at all frictional surface areas for signs of wear. Normal wear can be recognized as even wear, both on the belt and the grooves of the pulley. Even with normal wear, belts will eventually show evidence of cracking. Replace belts before or as soon as cracking becomes evident. Unusual signs of wear indicate some corrective action is necessary.

When checking, remember failed or partially failed belts may have been damaged by a bad pulley, a misaligned drive or by some faulty mechanical component.

Always check the condition of pulleys before replacing belts. Inspect the pulleys for chips, cracks, bent sidewalls, rust, corrosion, etc. Replace any defective pulleys.

### **EXTERIOR**

Some exterior parts of your motor home may be made of fiberglass. The finish on these parts is durable, but not indestructible. Any material and finish will deteriorate in time. Exposure to sunlight, moisture and airborne pollutants can chemically alter the composition of the base and finish materials and cause dulling and fading of the finish. Generally, changes in the finish due to weathering are cosmetic — they are on the surface of the part and do not affect its strength. Weathering can take several forms:

- \* Chalking — The surface finish has broken down into a fine powder. It usually will wash off.
- \* Fading — The color of the finish has changed. This can be caused by chemicals spilled on the surface, staining it, or by changes in the pigments used in the finish.
- \* Yellowing — Usually caused by chemical changes in the material and pigments.

The best insurance against these effects is routine

maintenance. If the finish is not washed thoroughly and waxed, the surface can deteriorate very rapidly. The following maintenance guidelines can help you reduce these weathering effects:

1. Wash the exterior of the motor home monthly, at least. Wash with a mild soap. Avoid strong alkaline cleaners and abrasives.
2. Wax the exterior at least once a year — twice, if possible — with a wax formulated for fiberglass. When waxing, always read and follow the instructions and precautions on the container. Some cleaners and waxes are recommended for use on only certain types of surfaces. Sometimes one part may weather more rapidly than others. In cases where this has happened, a light rubbing compound may be required. Always follow rubbing compound with a high-quality wax.

### **Stains**

Staining can generally be caused by two types of substances — water soluble and non-water soluble. Water soluble stains can usually be washed away with water and mild detergents or a fine cleanser. If you use a cleanser powder, first mix it with water forming a runny paste. Start with a small spot, and use light, circular rubbing motions. Follow the washing with wax.

Non-water soluble stains are usually oil-based. Removal of this type of stain may require the use of highly flammable or poisonous solvents. Refer this type of service to your dealer or an authorized Fleetwood Service Center. Wash the exterior of the motor home as you would your car or truck. Never use strong solvents or harsh abrasives to clean the exterior metal or fiberglass surfaces. A good quality automotive wax-polish will help maintain the finish.

### **Windows, Doors, Vents And Locks**

Keep moving parts of windows and latches adjusted and maintained. Lubricate the windows with a light oil or powdered graphite at least once a year. Check and tighten the screws holding the windows in place periodically. Check the weather sealant. See SEALANT RENEWAL. Clean screens by gently wiping with a damp cloth or soft flat brush.

Inspect the sealants around doors and windows every three months. See SEALANT RENEWAL.

Lubricate locksets, latches and hinges in entry doors and exterior storage compartments at least annually with powdered graphite. If the motor home is located at a beach or is exposed to salt air, more frequent lubrication may be required. Record the identification number of the keys in the records space provided in this manual. This information will help you get duplicate keys in the event of loss.

### **Sealant Renewal**

The adhesives and sealants used in the construction of your motor home were developed to remain waterproof under sustained effects of weather and vibration. However, even the finest materials will eventually dry out and lose their effectiveness under constant heat of the sun and attack by other elements. This section outlines the procedures that you must follow to maintain the weatherproof integrity of your motor home. Leak damage caused by neglect to follow these procedures may affect your warranty coverage.

Your dealer can perform the resealing inspection and work for you. He has current information on sealants used in your motor home, and can recommend the appropriate sealants for you if you prefer to do this work yourself. Always use the recommended sealants.

### **RUBBER ROOF SYSTEM Cleaning**

For normal cleaning, standard household detergents or cleansers may be used. Use any non-abrasive, common household detergent and plenty of water. Be sure to keep the sidewalls wet to reduce streaking.

Very stubborn stains may require solvents or non-water based cleaning agents. Consult your dealer for more information.

### **Care**

The roof does not require annual coatings or additional sealants. Periodic washing with soap and water is all that is required.

The rubber roof material can be cut by sharp objects. Use caution when loading sharp articles on the roof. If you add accessories or new equipment on the roof, be sure the installer is qualified to work on the rubber roof material. This is required under the terms of the warranty.

Repair kits are available through your dealer. The roof requires special adhesives and material.

Please see your Owner's Information Kit for additional material on the roof system.

**WARNING: RUBBER ROOF MATERIAL IS SLIPPERY WHEN WET.**

### **Door And Window Resealing**

Inspect the sealants around windows and doors at least every three months. If any of the following defects are evident during inspection, the affected areas must be resealed:

- \* Excessive amount of sealant protruding from joints

- \* Sealant cracked or peeling
- \* Voids in sealant

**NOTE: Do not seal the bottom flanges of windows and doors. Two sealant voids have been intentionally left in the bottom flange sealant to provide exterior drainage in the event of leakage.**

If you find any of the above defects:

1. Use a plastic scraper to remove excess sealant.
2. Clean all areas to be resealed with mineral spirits and clean rags. **WARNING: MINERAL SPIRITS IS A FLAMMABLE LIQUID. USE EXTREME CARE WHEN HANDLING AND USING. DO NOT EXPOSE TO OPEN FLAME, SPARKS, OR SMOKING MATERIALS. DO NOT USE IN UN-VENTILATED AREAS.**

Make sure that all areas to be resealed are absolutely dry before new sealant is applied.

## **INTERIOR**

### ***Upholstery And Drapes***

Frequent vacuuming or light brushing between cleanings will help prevent accumulation of dirt and grime. Use of water-based or detergent based cleaners

may cause shrinking or other fabric damage. Water stains may become permanent.

**WARNING: DO NOT USE LACQUER THINNER, NAIL POLISH REMOVER, CARBON TETRACHLORIDE, SPOT REMOVER, GASOLINE, OR NAPHTHA FOR ANY CLEANING PURPOSE. THESE PRODUCTS MAY CAUSE DAMAGE TO THE MATERIAL BEING CLEANED, AND MAY BE HIGHLY FLAMMABLE OR POISONOUS.**

### ***Wall And Ceiling Panels***

The paneling and the ceiling of your motor home may be any of several finishes and textures. Never use harsh detergents or abrasive cleaners on walls or ceilings. Most surfaces will clean with a soft cloth moistened with mild liquid detergent in warm water. Do not use large amounts of water which could saturate the material.

### ***Floors And Carpeting***

Vinyl flooring requires only washing and periodic waxing. Vacuum carpeting regularly, and clean it with a quality carpet cleaner.

# PREPARING THE MOTOR HOME FOR LONG-TERM STORAGE

## STORAGE CHECK LIST

The following check lists will help you perform the steps necessary to prepare your motor home for storage. Storage conditions vary, and several check lists are provided: a) Short-term Storage Above Freezing, b) Long-term Storage Above Freezing, c) Winter Storage Below Freezing. Use the check list that applies to the storage conditions you anticipate. These check lists can not include every detail required and you may want to expand them to suit your needs.

### **Short-term Storage (less than 60 days) Above Freezing**

- \* Wash the motor home exterior and underside. Hose off accumulations of mud and road salts. Rinse the exterior weekly to remove accumulations of dust and debris.
- \* Inflate tires to maximum rated cold pressure.
- \* Park the motor home as level as possible front to rear and side to side. Block wheels front and rear, and leave the parking brake OFF.
- \* Check the charge in both the vehicle and auxiliary batteries with a hydrometer. Hydrometer reading should be 1.255. Add colorless, odorless drinking water if necessary, and charge to a reading of 1.255.
- \* Remove battery cables. Clean terminals, top and sides of batteries and battery boxes. Reinstall cables, dress with a plastic ignition spray.
- \* Drain holding tanks, toilet, and living area water systems. Turn off water pump and water heater master switches.
- \* Turn off LP gas at tank valve.
- \* Turn off refrigerator and furnace.
- \* Turn all range and oven burner valves and pilot valves (if equipped) off.
- \* Remove all perishables from refrigerator and galley cabinets. Block refrigerator open to reduce odor buildup. An open box or tray of baking soda in the refrigerator will help absorb odors.
- \* Open closet doors, drawers, and cabinets so air can circulate through them.
- \* Slightly open one window toward the front and one toward the back for ventilation.
- \* Close all roof vents. Be sure vent fan and range hood fan switches are off.

- \* Cover exterior vents (water heater, furnace, range hood, refer) to prevent insects from getting in. Be sure to remove all covering material before using appliances or vents.
- \* Cap or close holding tank drain, city water inlet and fresh water fill spout.
- \* Turn off all radios, TVs, interior and exterior lights.
- \* Close drapes and curtains.
- \* Check motor home weekly. Start and run the engine for about 15 minutes weekly. Check engine oil, transmission fluid, coolant levels.

### **Long-term Storage Above Freezing**

- \* Perform all the preceding, except run engine to normal operating temperature. Drain engine oil, replace filter, refill engine with fresh oil. Operate air conditioner to lubricate compressor seals.
- \* Remove windshield wiper blades and store them inside the motor home.
- \* Disconnect batteries and check charge (Specific Gravity) with a hydrometer every 30 days. Recharge if necessary.
- \* Rather than run the engine every week, run the engine every 30 days. Turn the vehicle air conditioner ON during this run. Check fluid levels as for Short-term Storage.
- \* Shield tires from direct sunlight.
- \* Check tire inflation pressures every 30 days. Maintain maximum rated cold inflation pressure.
- \* Remove high grass or weed growth.

## WINTERIZATION AND WINTER STORAGE

Winter in most parts of North America can be harsh, and can take its toll on almost all types of vehicles and equipment. The rigors of winter should not discourage you from enjoying the RV life-style, though. Thoughtful planning and preparation for the winter season can help eliminate equipment failures and breakdowns, and can extend the life of your motor home and its systems.

Your dealer can advise you concerning specific winterization procedures and products for your climate area or the areas through which you will be traveling. Your dealer may also provide winterization service for all appliances and systems in the motor home. Before the winter traveling season starts, service the motor home chassis thoroughly. Follow the lubrication schedule and be sure all chassis components are ready for the stress of winter driving. Thoroughly

wash and wax the motor home body. Check undercoating, and re-apply if necessary. Check windshield wiper blades and replace them if they are broken, torn or fatigued. Check tires, brakes, and lights. A "physically fit" motor home will stay in shape much better through the winter.

If you choose not to travel during the winter and will be storing your motor home during periods of freezing temperatures, follow a thorough Winter Storage procedure.

### **Winter Storage Below Freezing**

Protecting the plumbing systems in your motor home is the most important aspect of long-term winter storage. Extensive damage to the plumbing fixtures and components, as well as other potential problems can be avoided by proper draining and antifreeze protection. The following is a procedure check list you can follow if you prefer to winterize your vehicle yourself. (See PLUMBING Section)

### **Water System Winterizing**

Read this section completely before performing winterization.

- \* Perform a complete chassis service and lubrication as outlined in the Chassis Operator's Manual.
- \* Drain the fresh water tank by opening the water tank drain valve. Leave valve open.
- \* Turn water pump on (12-volt DC power on.) Open a cold water faucet. When the flow of water stops, turn the pump off.
- \* After opening hot and cold water faucets, open the drain valves on HOT and COLD water pipes. These valves are located in the water utility compartment and drain out the bottom of the motor home. Leave these valves open.
- \* Drain the water heater by opening the drain valve at the bottom of the heater and open the safety valve. Open the hot water faucets.
- \* Open all cold water faucets, and depress the flush pedal or pull the flush levers on the toilet.
- \* When each faucet has been opened, drained, and closed, close the water line drain valves, and the fresh water tank drain valve.
- \* Drain the shower head by opening the valve. Let all water drain out the tub spout. Leave the valve open.
- \* Drain the waste water system by following the normal procedure for draining the holding tanks. (See PLUMBING Section)
- \* Apply graphite lubricant to the knife valve actuator rod(s).

- \* Be sure ALL water from ALL plumbing fixtures has been drained.

**CAUTION: DRAINING THE WATER SYSTEM ALONE WILL NOT PROVIDE ADEQUATE COLD WEATHER PROTECTION. IF THE MOTOR HOME IS TO BE UNHEATED DURING FREEZING TEMPERATURES, CONSULT YOUR DEALER FOR THE BEST WINTERIZING PROCEDURE FOR YOUR CLIMATE. YOUR DEALER CAN WINTERIZE YOUR MOTOR HOME FOR YOU OR CAN SUPPLY YOU WITH ONE OF THE SPECIAL ANTIFREEZES WHICH ARE SAFE AND APPROVED FOR USE IN RV WATER SYSTEMS. FOLLOW THE INSTRUCTIONS FURNISHED WITH THE ANTIFREEZE.**

**WARNING: DO NOT USE AUTOMOTIVE OR WINDSHIELD WASHER ANTIFREEZE IN THE MOTOR HOME WATER SYSTEM. THESE COULD BE HARMFUL IF SWALLOWED.**

- \* Pour approximately five gallons of approved RV water system antifreeze into the fresh water tank. Be sure tank drain valve is closed.
- \* Turn the water pump master switch ON.
- \* Open each cold water faucet, run the water pump and let about a cup of antifreeze solution flow continuously through each faucet. Close each cold water faucet.
- \* Check the antifreeze level in the water tank. Add antifreeze solution if necessary.
- \* Depress the flush pedal (or otherwise operate the flush mechanism) on the toilet until the antifreeze solution flows continuously. Release flush mechanism.
- \* Check the antifreeze level in the water tank. Add antifreeze solution if necessary.
- \* If your vehicle is equipped with a water heater bypass kit, winterize the water heater according to the instructions provided with the kit. If you do not have a bypass kit, you will have to fill the water heater with antifreeze solution by the water pump. You can then winterize the hot water lines by opening each hot water faucet, allowing antifreeze solution to flow continuously, and then close each faucet. This will require considerably more antifreeze solution, and you may choose to do this step before winterizing the cold water lines so you can recycle the solution.
- \* When filling the plumbing systems with antifreeze, be sure to open and operate all fixtures and valves allowing the antifreeze solution to flow freely.
- \* Pour another cup of antifreeze solution down each drain.

- \* Install all protective caps:
  - \* Water tank fill
  - \* City water inlet cap
  - \* Waste tank drain outlet cap

### **General Vehicle Winter Storage Check List**

- \* Thoroughly service the motor home chassis as discussed above.
- \* Perform steps as listed under Long-term Storage check list.
- \* Check engine coolant level and antifreeze protection. Drain and flush engine cooling system and add antifreeze to protect the system to the lowest expected storage temperature (at least -20°F).
- \* Close and cover all vents to prevent entry of snow or small animals and insects.
- \* Service and winterize the AC generator (if equipped) as outlined in the generator operating manual included in your Owner's Information Package.
- \* Check the sealant around all roof and body seams and windows. Reseal if necessary. See "SEALANT RENEWAL" section.
- \* Lubricate all locks and hinges with light oil or graphite.
- \* If you expect to store the motor home for an extended period, you may want to support the weight of the motor home on appropriate blocks or jack stands. This will take the weight off the tires and reduce the formation of flat spots. Do not use hollow core concrete blocks for blocking. Cover the tires with cloth or cardboard. You may also choose to coat them with a special tire dressing to reduce deterioration from ultraviolet rays and weather. If you block the vehicle this way, you may reduce tire pressure to about 10-20 psi. Be sure to reinflate the tires up to the specified pressure before you remove the blocks or jack stands.
- \* Winterize the LP gas system. Your LP dealer or service station can perform this for you. Cover the regulator to prevent moisture from entering and freezing in the vent opening.
- \* During extended storage, charge and remove both the vehicle and auxiliary batteries. Store them in a cool, dry place, and check the charge and water level every 30 days.
- \* Remove all perishables and canned goods.
- \* Clean refrigerator, and prop door open to allow circulation of air.
- \* Remove, clean and replace air conditioner filters.
- \* Cover the air conditioner shroud(s).

- \* Mask the windows on the inside to reduce curtain, drape, and carpet fading.
- \* Thoroughly clean the interior of the motor home, including carpets, counter tops, lavy, tub & shower, and galley.
- \* Remove batteries in clocks or other battery-powered devices.
- \* Remove snow accumulations as often as possible.

### **Reactivating The Motor Home After Storage**

If the motor home was properly and carefully prepared for storage, taking it out of storage will not be difficult. You should not experience any but minor surprises such as animal nests underneath or minor body scratches, and of course dirt accumulations on the outside. The following procedure check list assumes that you stored the motor home with care. If you didn't, and extensive freeze damage or other serious deterioration has occurred, please consult your dealer or an authorized Fleetwood Service Center for advise.

- \* Thoroughly inspect the outside of the vehicle. Look for animal nests in wheel wells, under the hood, or in other out of the way places.
- \* Open all doors and compartments. Check for animal or insect intrusion, water damage, or other deterioration.
- \* Remove all appliance vent, ceiling vent and air conditioner coverings. Be sure all furnace, water heater, and refrigerator openings are clear and free of debris or insect nests, webs, etc.
- \* Check all chassis fluid levels — engine oil, engine coolant, power steering fluid, brake fluid, transmission fluid, rear axle oil.
- \* Check charge level in batteries. Refill and recharge as necessary. Reinstall batteries if necessary. Be sure cable ends and terminals are clean and free of corrosion.
- \* Check tire pressures. Reinflate to specified cold pressure.
- \* If the motor home has been stored on blocks or jacks, remove these.
- \* Disconnect vehicle air conditioner clutch wires. Turn A/C compressor by hand a few turns to loosen the seal. If you can turn the compressor, reconnect the wires. If the compressor cannot be turned by hand, do not reconnect the clutch wires, and do not operate the vehicle air conditioner until the system is checked by a qualified air conditioning technician.
- \* Remove masking from inside windows.

- \* Open vents and windows for ventilation.
  - \* Be sure all 12-volt DC and 120-volt AC circuit breakers are off.
  - \* Start engine. Check instruments for proper readings. If oil pressure indicator does not indicate sufficient oil pressure, shut down engine immediately. Have problem diagnosed by your dealer, or other qualified chassis technician.
  - \* Be sure all other engine instruments indicate proper readings. Run engine up to operating temperature. Shut engine down. Check all fluids. Top up if necessary.
  - \* During engine run, check the operation of headlights, taillights, turn signals, backup lights, clearance lights, license plate light, emergency flashers. Operate the vehicle air conditioner.
  - \* Drain, flush, and sanitize the fresh water system as outlined in the "PLUMBING" section.
  - \* Drain the holding tanks as outlined in the "PLUMBING" section. Inspect the drain hose for leaks. Replace if necessary — repairs are usually not effective.
  - \* Operate all faucets and fixtures in the fresh water system. Check for leaks at all joints and fittings. Repair if necessary.
  - \* Inspect the LP gas system. Remove the regulator cover, check for damage. Inspect all pipes and fittings in the system. Check for leaks as outlined in the "LP GAS" section. If the LP tank shows signs of rust or corrosion, sand and paint it as necessary.
  - \* Turn on 12-volt DC circuit breakers and inspect fuses. Operate all 12-volt lights and accessories.
  - \* Install new batteries in battery-operated devices.
  - \* Check monitor panel operation.
  - \* Open and operate vents and vent fans, including the range hood fan.
  - \* Operate each LP gas appliance. Observe all burner/pilot flames for proper color and size. In any case, have the LP gas regulator adjusted for proper pressure.
  - \* Inspect the 120-volt electrical system — power cord, converter, all outlets, and any exposed wiring. If defects are found, refer service to your dealer or an authorized Fleetwood Service Center.
  - \* Prepare the AC generator for operation following instructions in the generator operating manual in your Owner's Information Package.
  - \* Turn on 120-volt AC circuit breakers.
  - \* Start and run generator.
  - \* Operate 120-volt AC appliances and air conditioners. Be sure to uncover air conditioner shroud(s).
  - \* Inspect and clean the interior.
  - \* Check the sealant around all roof and body seams and windows. Reseal if necessary. See "SEALANT RENEWAL" section.
  - \* Lubricate all exterior locks, hinges, and latches.
  - \* Reinstall windshield wiper blades. Check wiper/washer operation.
  - \* Wash and wax the exterior. Inspect the body for scratches or other damage. Touch up or repair as necessary. Flush the underside thoroughly.
  - \* Run thorough operational checks of steering, brakes, engine and transmission. Operate vehicle slowly during these checks to allow sufficient circulation of fluids and reseating of components.
- Your motor home should now be ready for a new traveling season. If you choose, your dealer can double check your preparation and correct any defects or make any necessary adjustments.